

MIA MI-12



PL - Przed rozpoczęciem zapoznać się z instrukcją montażu.
DE - Vor die montage, bitte beiliegende anweisungen folgen.
EN - Before starting, refer to the assembling advice in annex.
CZ - Před zahájením naleznete v montážním návodu.
SK - Pred začatím nájdete v montážnom návode.
RU - Перед началом обратитесь к инструкции по установке.
SR - Пре почетка pogledajte uputstva za instalaciju.
HR - Prije početka pogledajte upute za instalaciju.
HU - Az összeszerelési munkálatok megkezdése előtt kérjük.
ismerkedjen meg az útmutató tartalmával.

lenart.



120 min

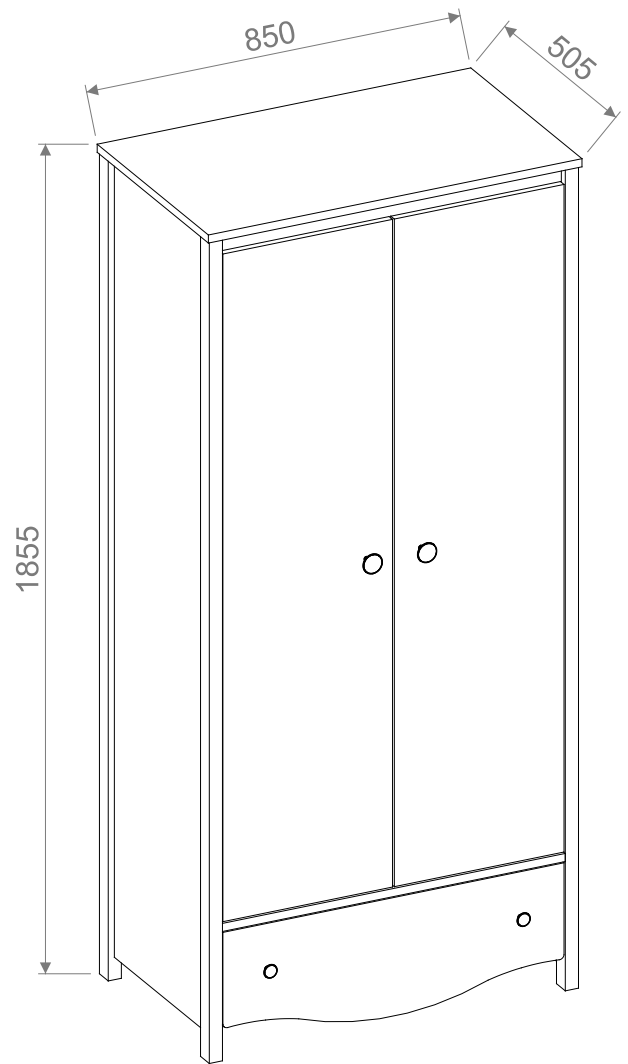

Company: „DIG-NET” LENART sp.j.
Mroczeń 65a, 63-611 Mroczeń
e-mail: info@dignet.eu

Potrzebne narzēdzia/ Benötigtes Werkzeug/ Required tools/ Potřebné nástroje/
Potrebné nástroje/ Необходимые инструменты/ Potreban alat/ Szereléshez szükséges szerszámok

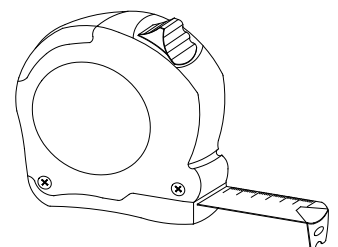
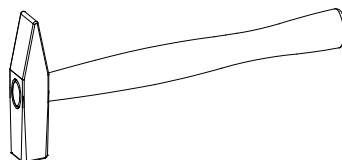
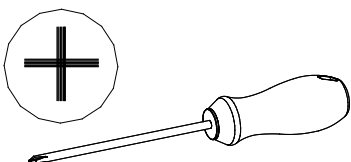





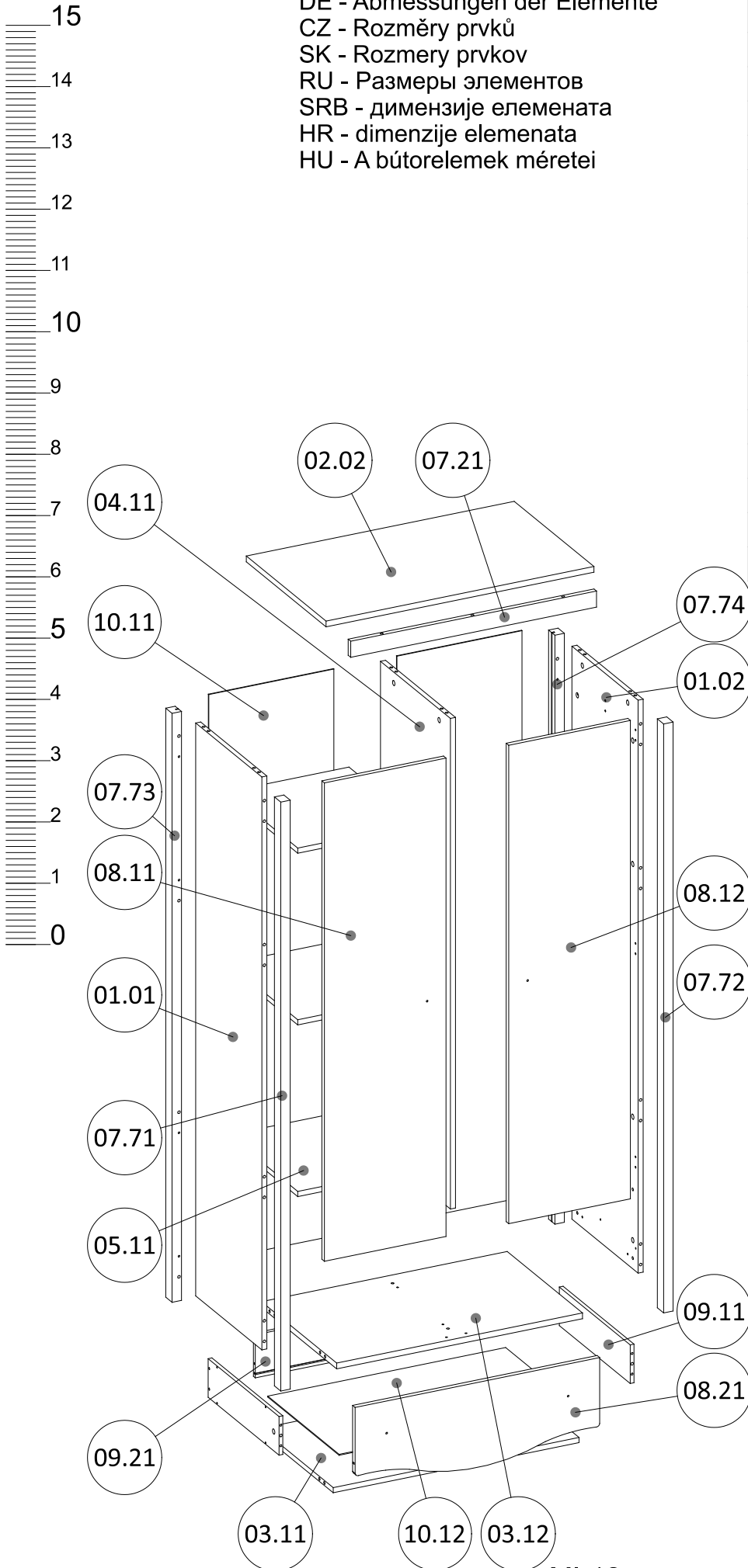

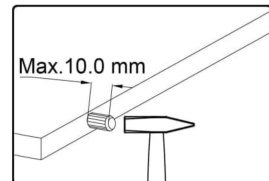
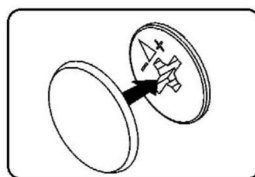
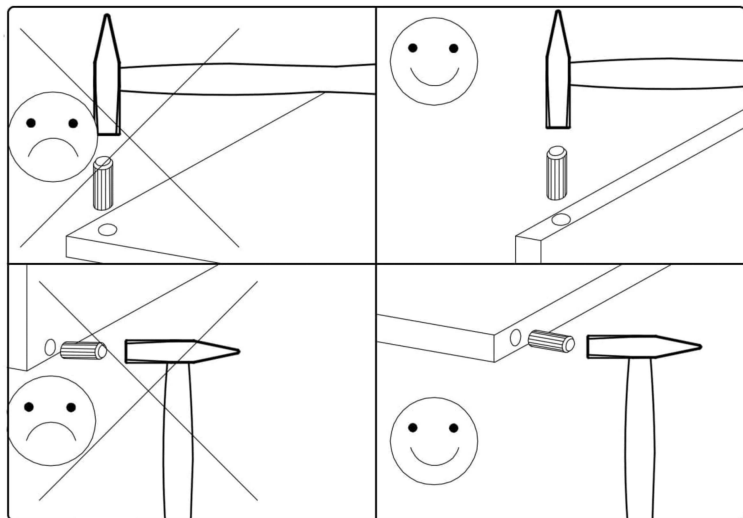
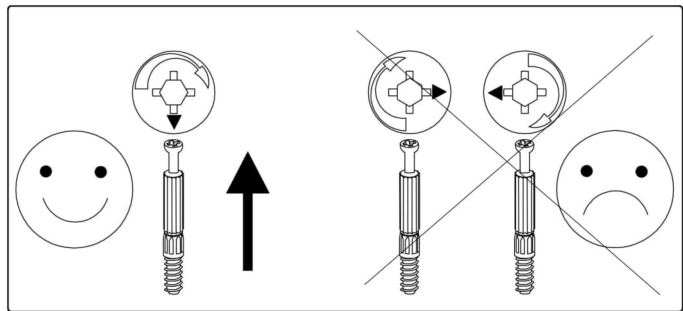
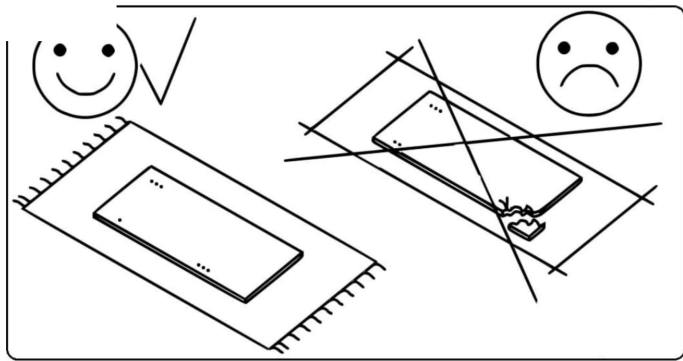

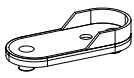
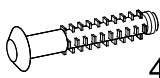

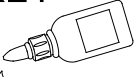

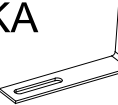

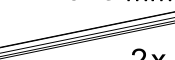

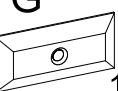



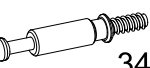

PL - Wymiary elementów
 EN - The dimensions of the elements
 DE - Abmessungen der Elemente
 CZ - Rozměry prvků
 SK - Rozmery prvkov
 RU - Размеры элементов
 SRB - димензије елемената
 HR - dimenzije elemenata
 HU - A bútoreslemek méretei

01.01	1782.0	420.0	1	1/2
01.02	1782.0	420.0	1	1/2
02.02	850.0	506.0	1	2/2
03.11	780.0	460.0	1	2/2
03.12	780.0	477.5	1	2/2
04.11	1526.0	444.0	1	1/2
05.11	382.0	439.0	3	2/2
07.21	780.0	50.0	1	2/2
07.71	1832.0	40.0	1	1/2
07.72	1832.0	40.0	1	1/2
07.73	1832.0	40.0	1	1/2
07.74	1832.0	40.0	1	1/2
08.11	1488.0	386.0	1	2/2
08.12	1488.0	386.0	1	1/2
08.21	776.1	264.5	1	2/2
09.11	450.0	120.0	2	2/2
09.21	731.0	134.0	1	2/2
10.11	1763.0	397.0	2	1/2
10.12	755.0	453.0	1	2/2



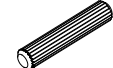

WDS  4x	KP 6x40  4x	W34 4x16  1x	KL1  1x	G2 2,0x20  22x	TK  14x
KA  1x	H2E  6x	Z2  6x	D L=375 mm  2x	PP6 Ø5  14x	PR5 L=450  1x
PG  10x	NA20 Ø20 K-01  22x	U2 Ø26  2x	WE61 5x13  6x	U1 Ø45  2x	WE66 5x9  4x
W7 4x13  16x	K2 8x30  35x	TM1  34x	WE61 5x13  6x	S42 4x25  2x	M12 Ø15x12  32x
M10 Ø15x10  2x	K1 6x30  4x	SG  4x	M12 Ø15x12  32x		

Proszę sprawdzić kompletność okuć przed montażem
Bitte überprüfen Sie die Vollständigkeit der Fittings vor der Montage
Please check the completeness of the fittings before assembly
Пожалуйста, проверьте комплектность фурнитуры перед установкой

Prosim zkontrolujte úplnosť konektorů před instalací
Prosim skontrolujte úplnosť konektorov pred inštaláciou
Prije montaže provjerite cjelovitost okova
Pre postavljanja proverite kompletnost okova

1

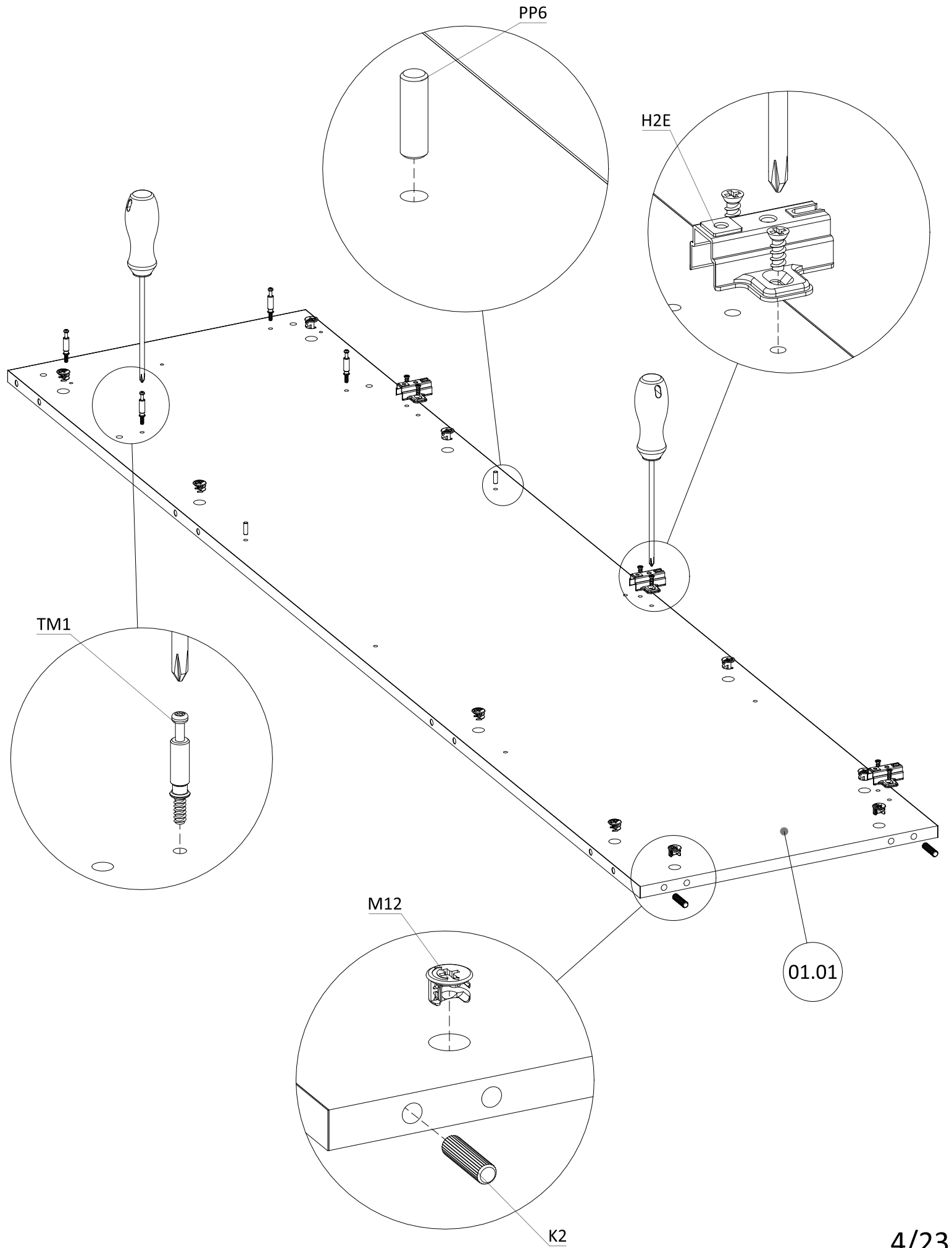
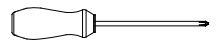
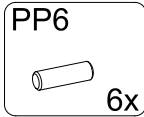
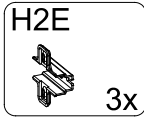
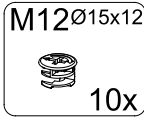
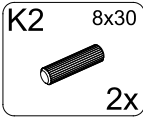
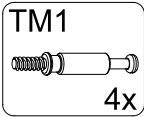

2

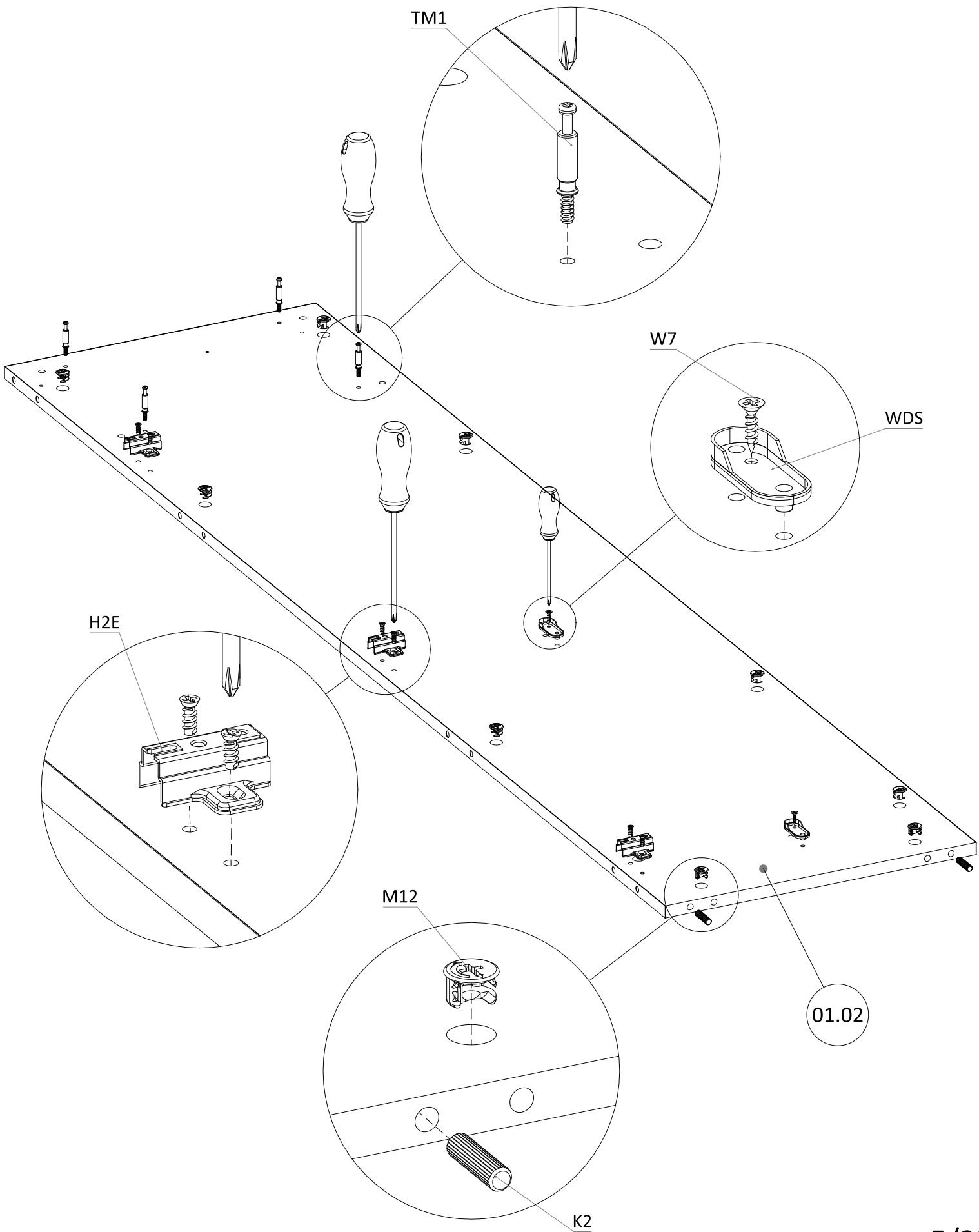
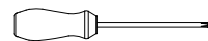
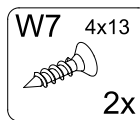
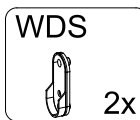
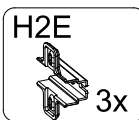
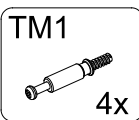
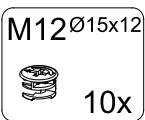
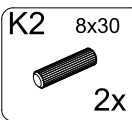

3

- K2** 8x30 4x
- M12** $\varnothing 15 \times 12$ 4x
- TM1** 2x
- PP6** 2x

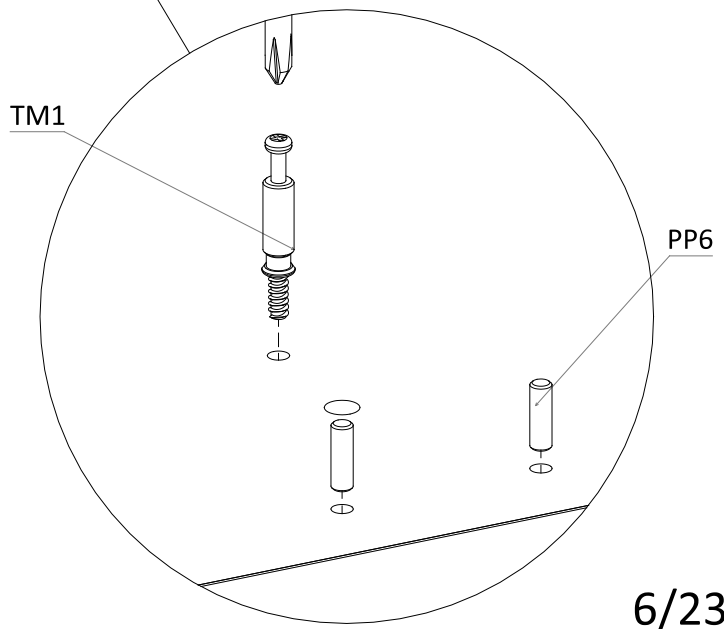
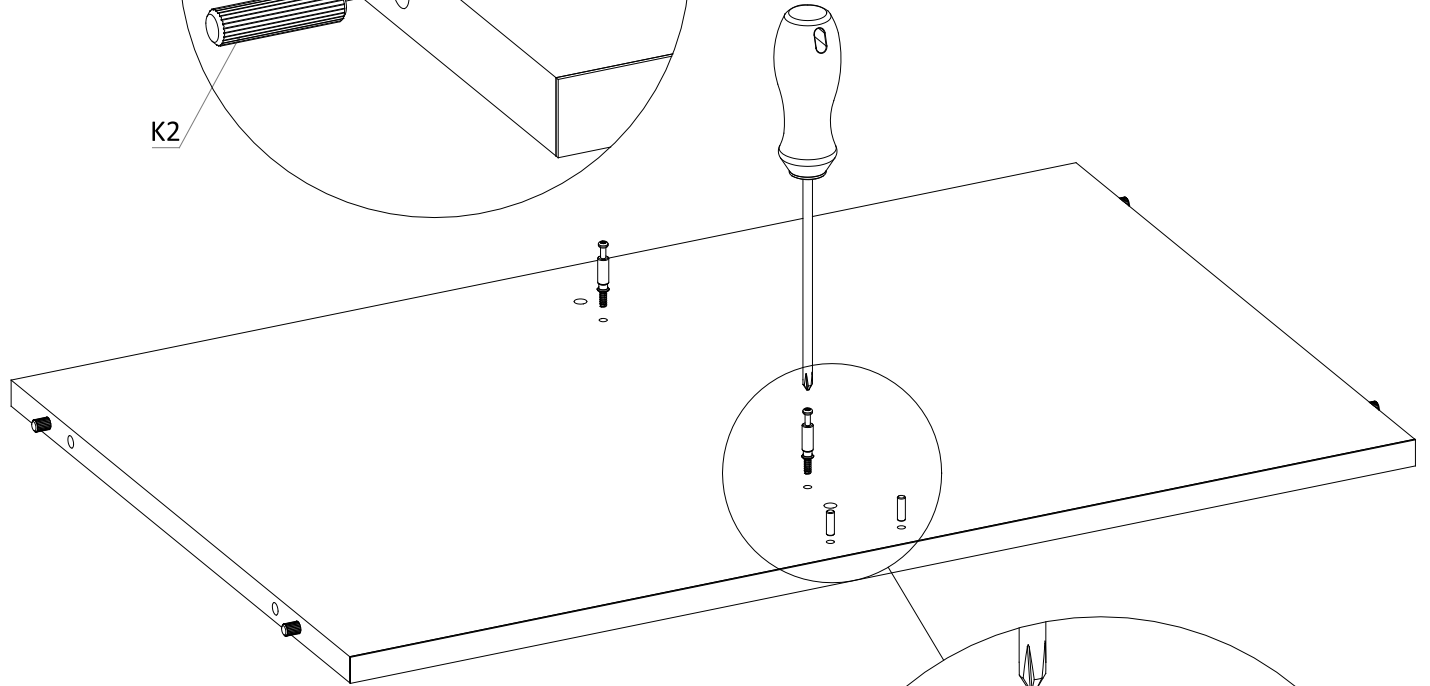
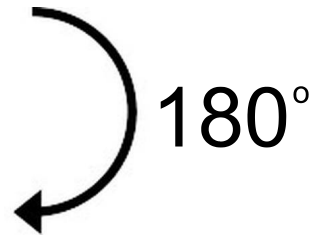
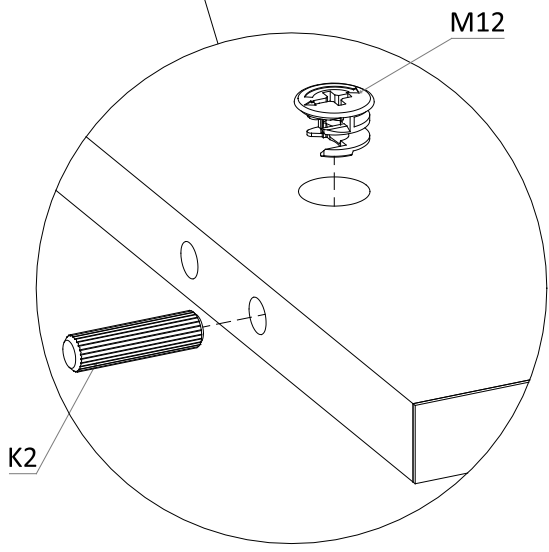
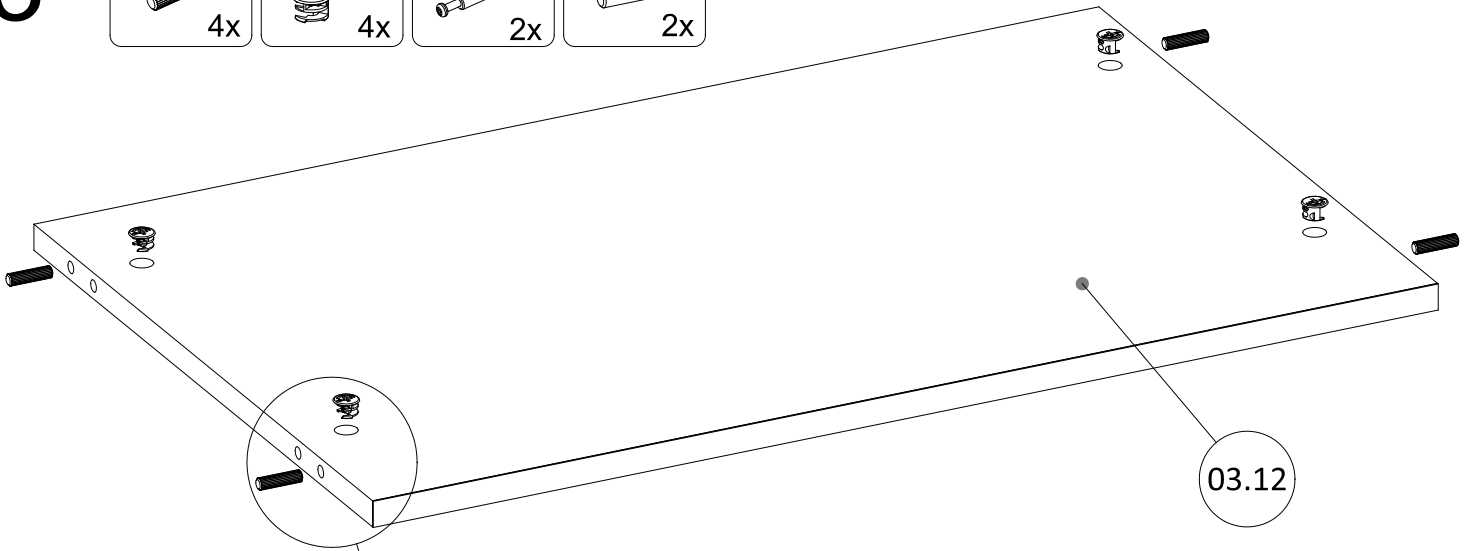
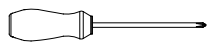

4

TM1
6x

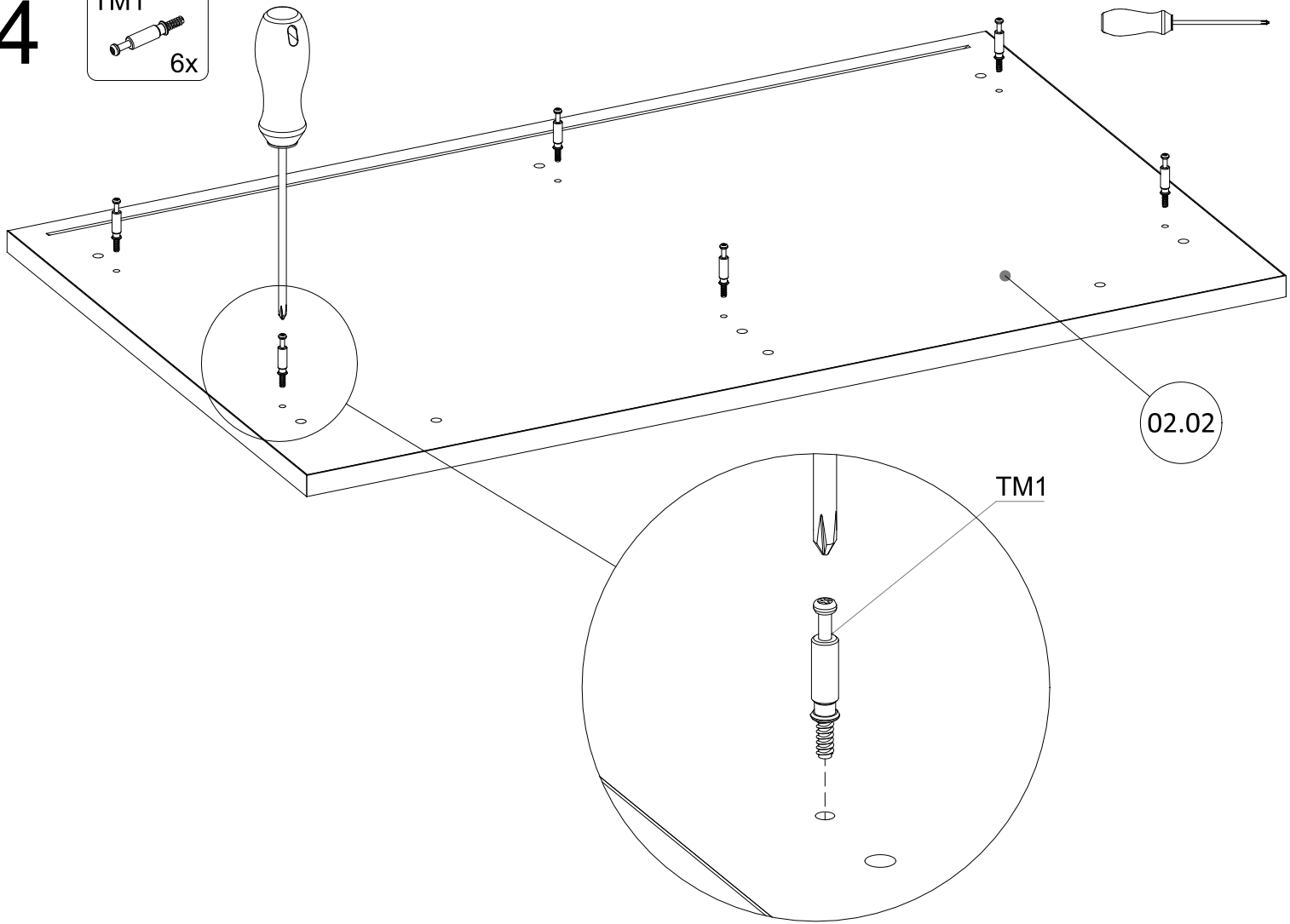

5

K2 8x30
4x

M12 Ø15x12
4x

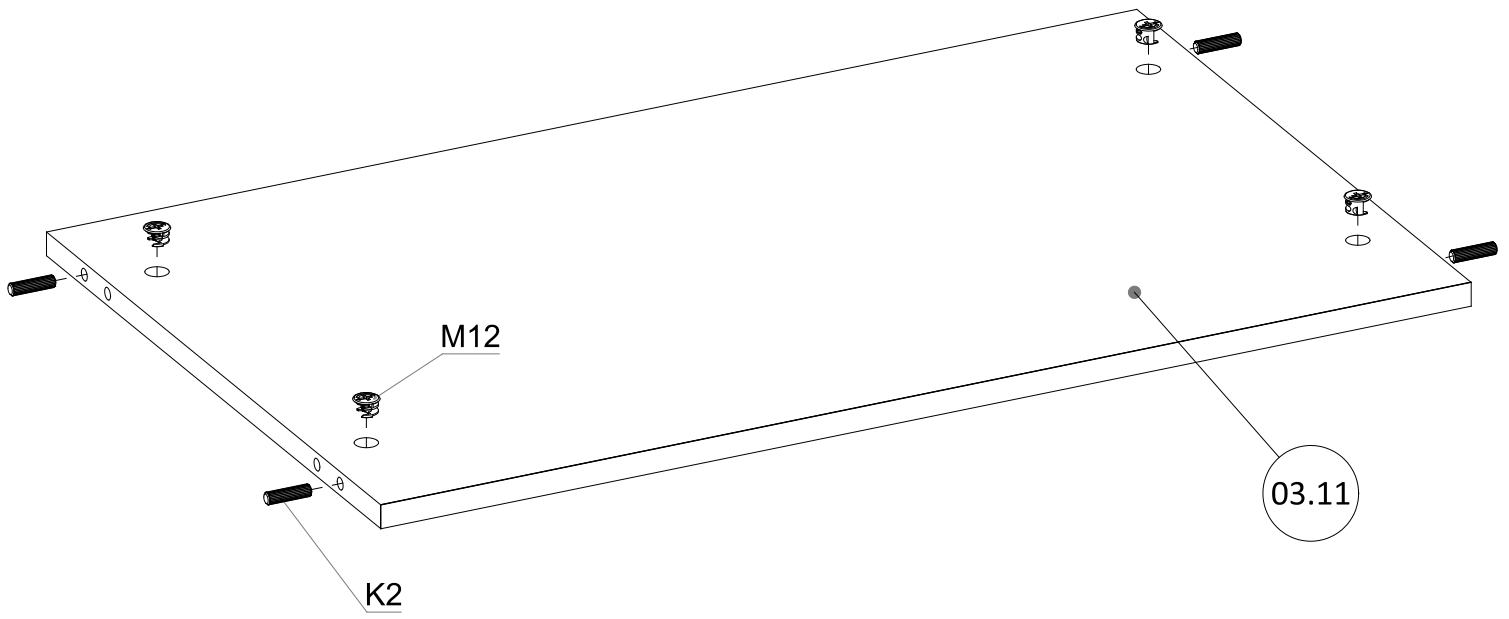

6

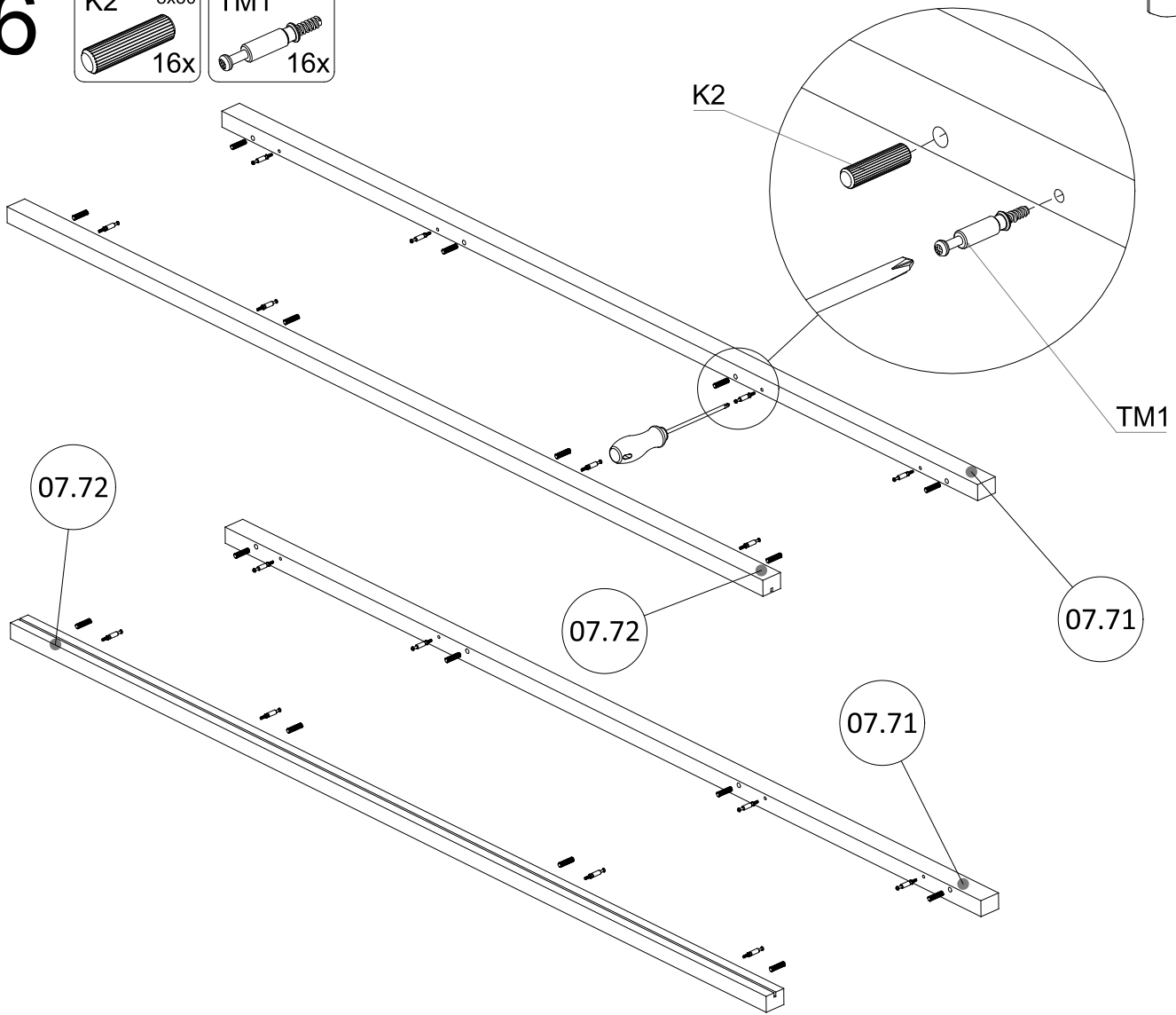
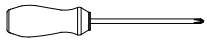
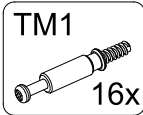
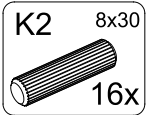

7

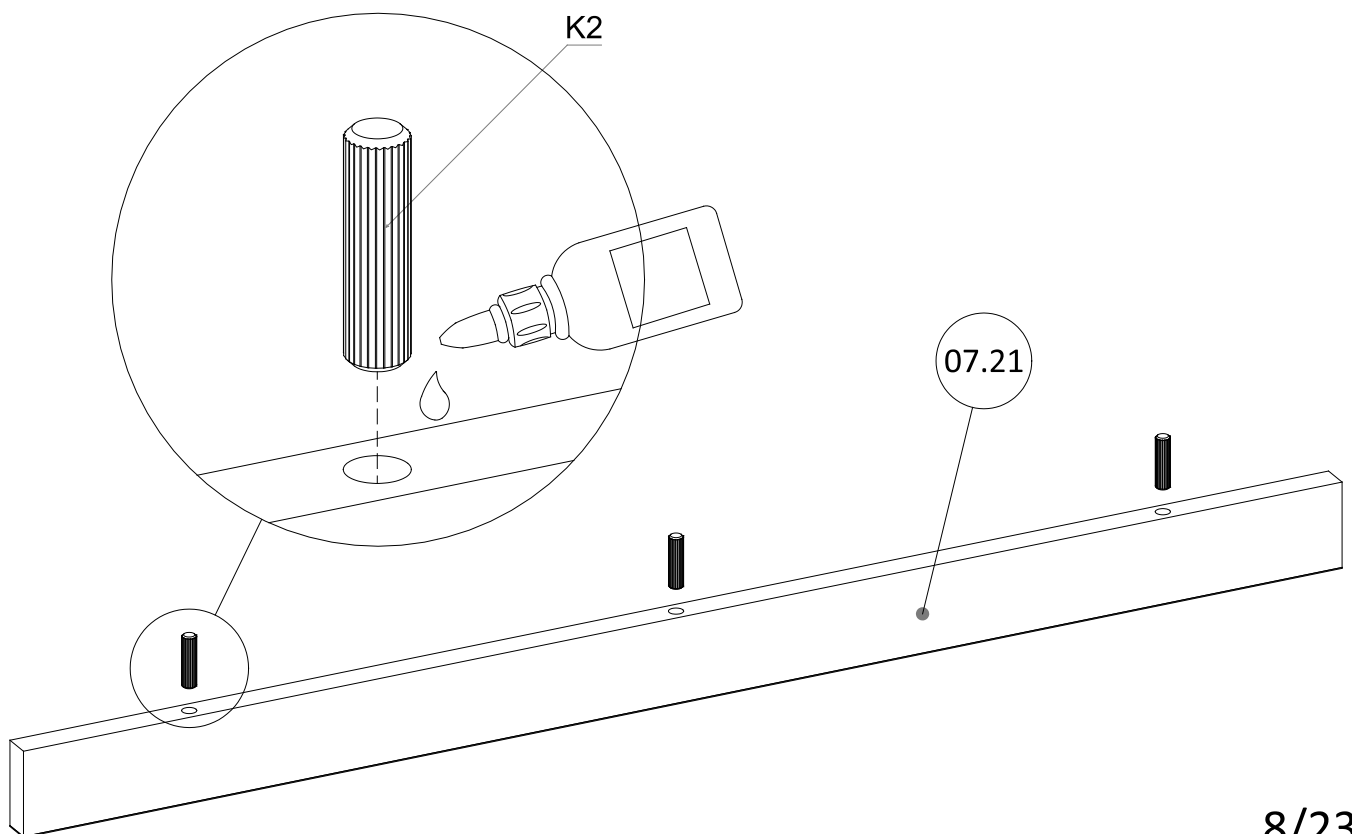
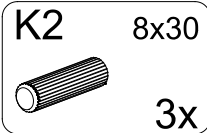
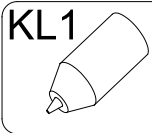

8

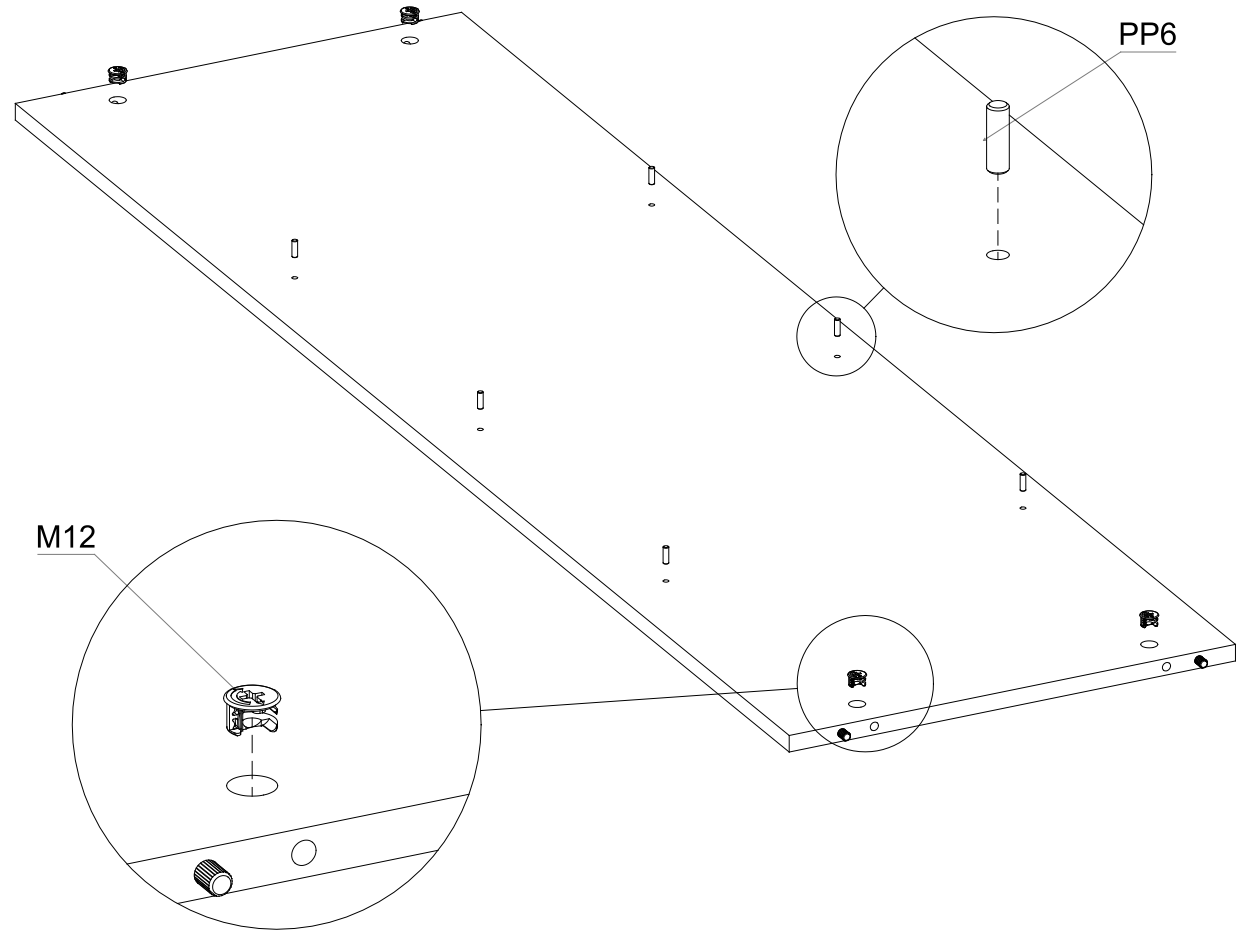
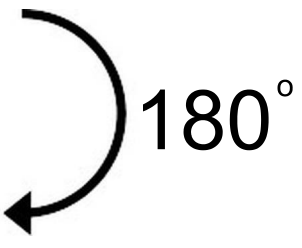
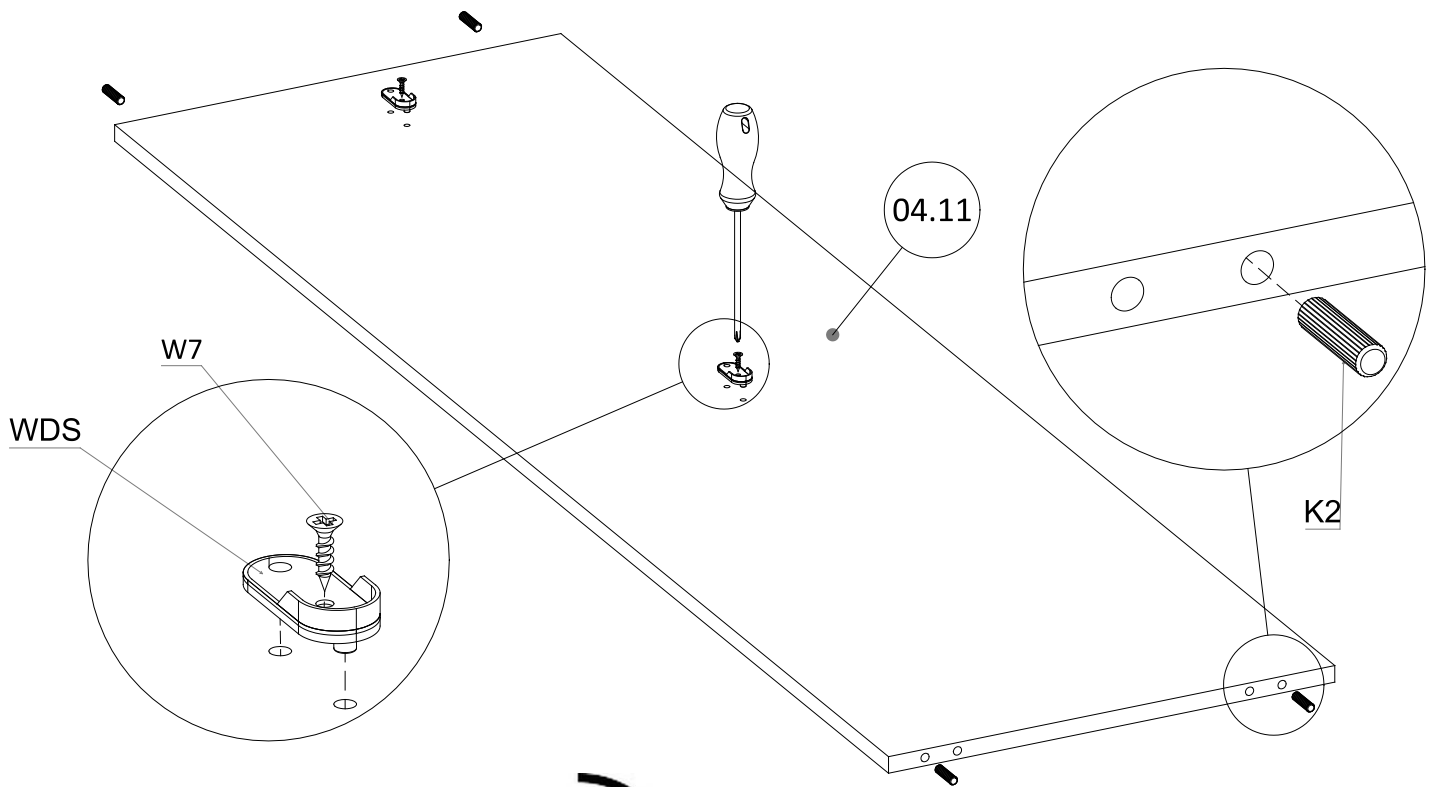
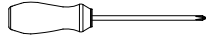
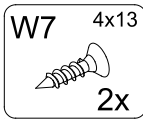
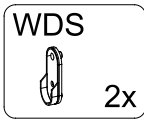
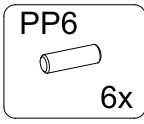
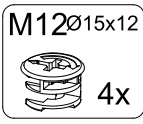
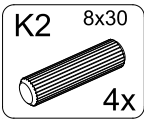

9

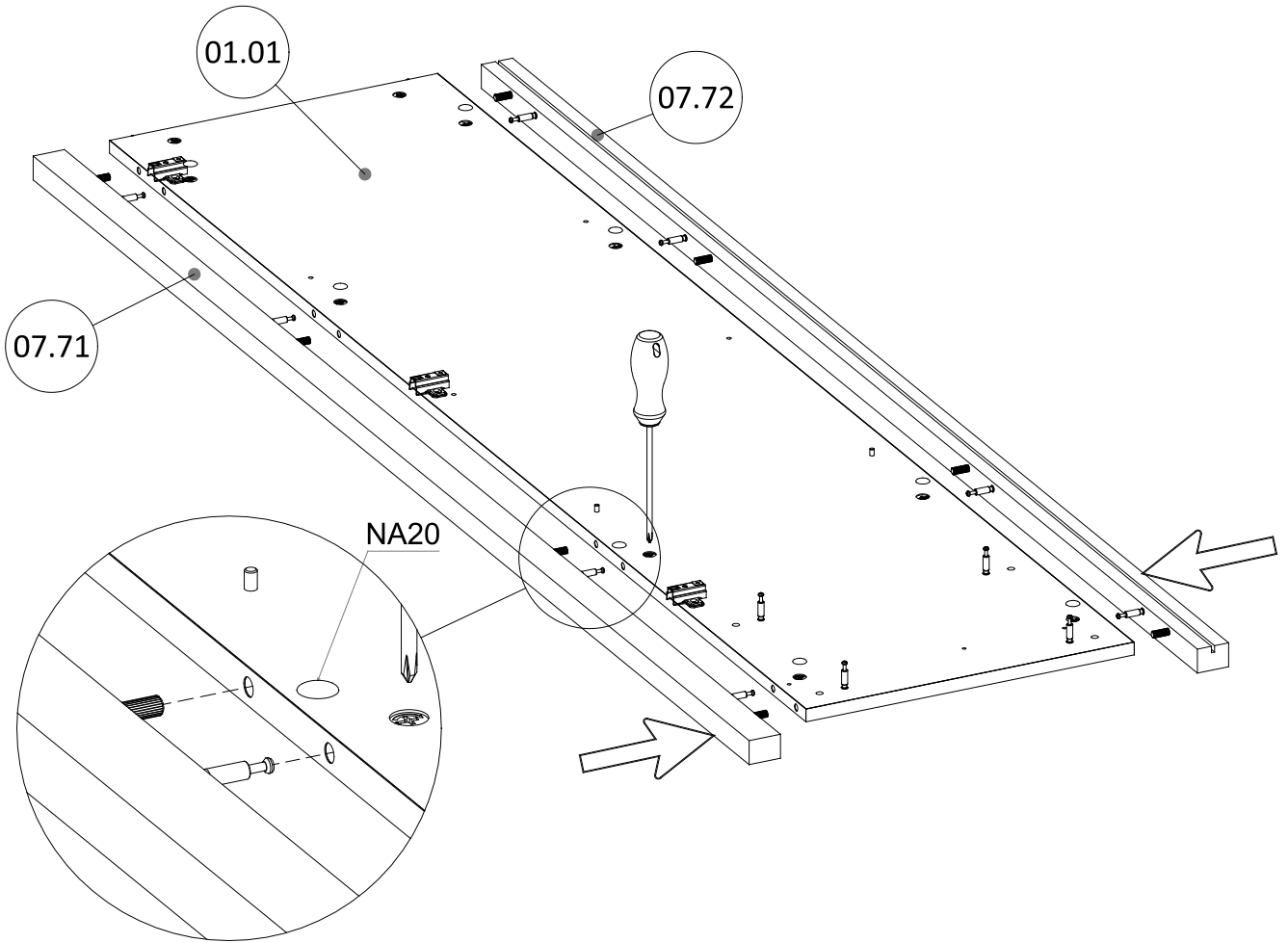
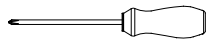
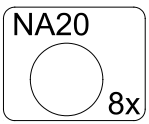

10

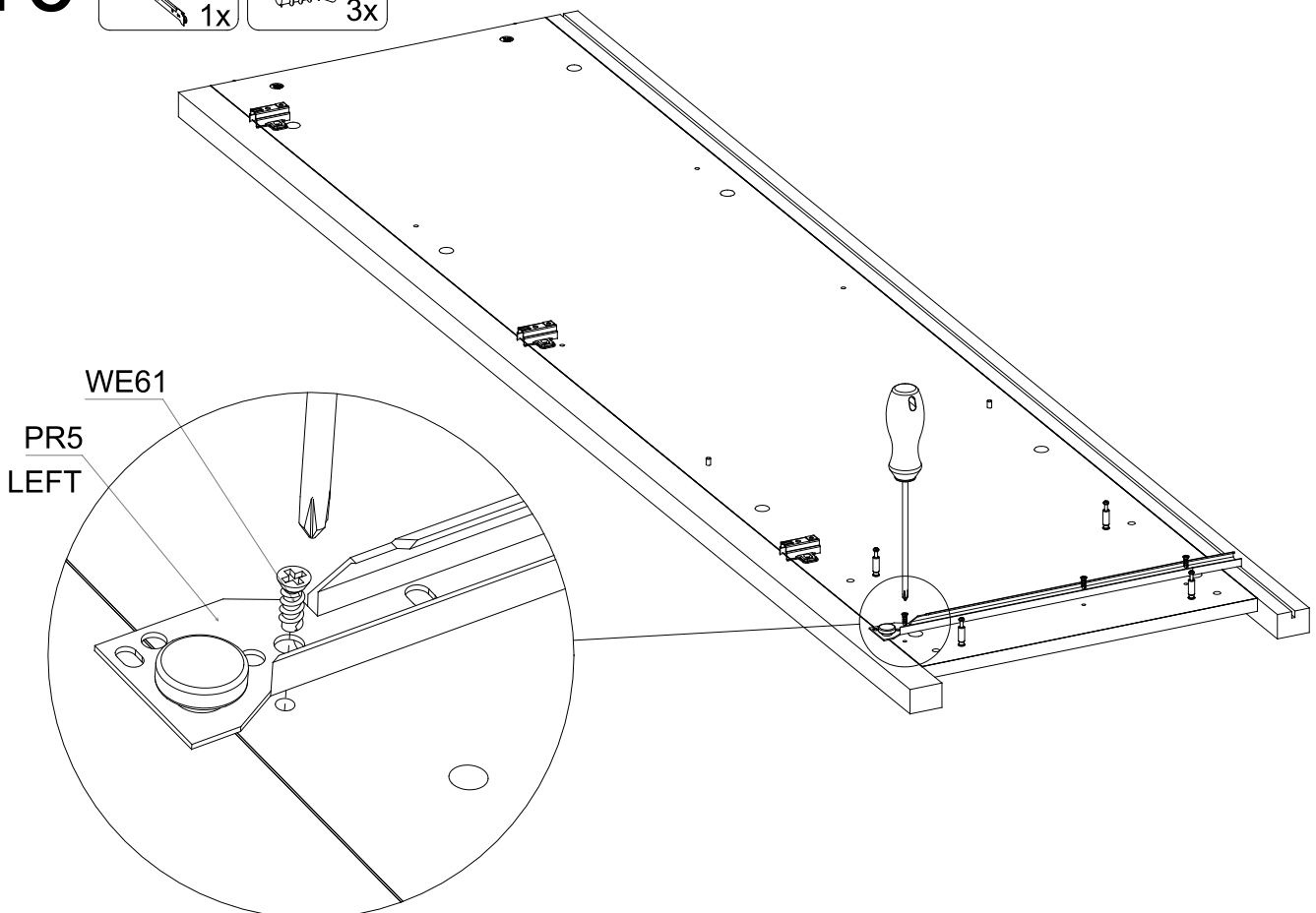
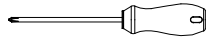
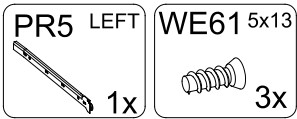

11

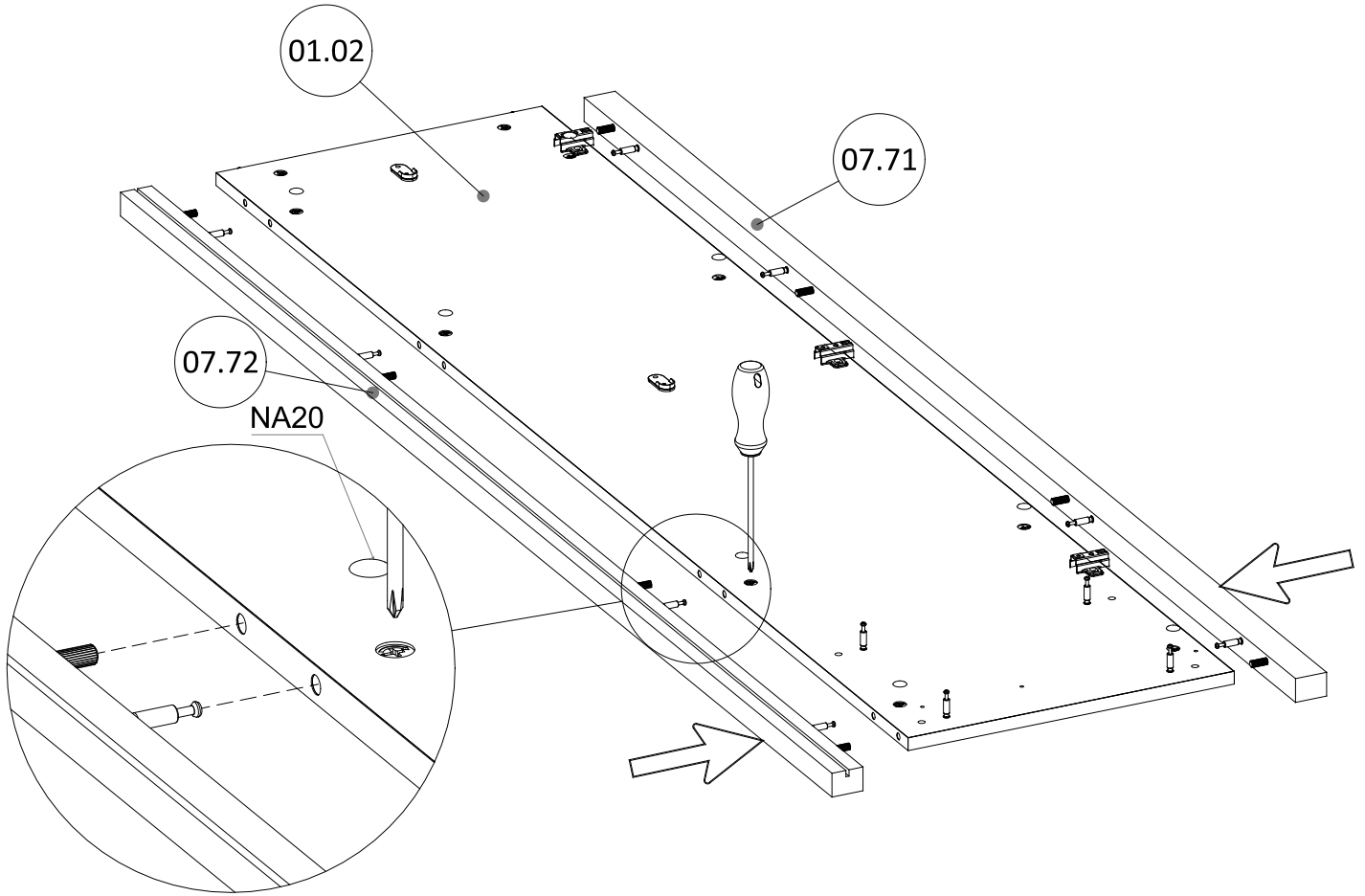
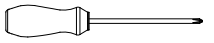
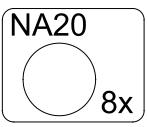

12

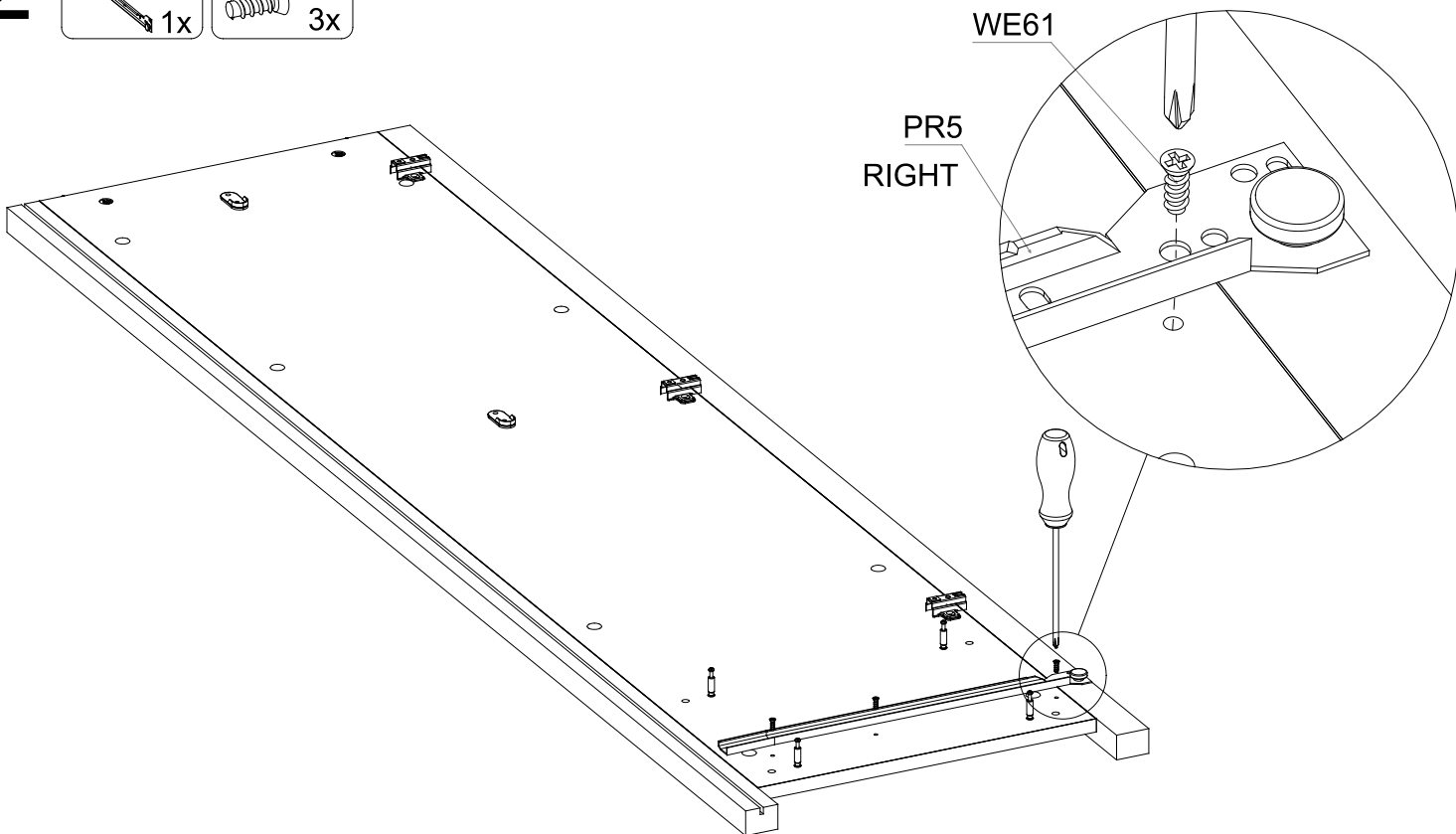
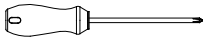
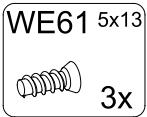
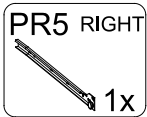

13

NA20
4x

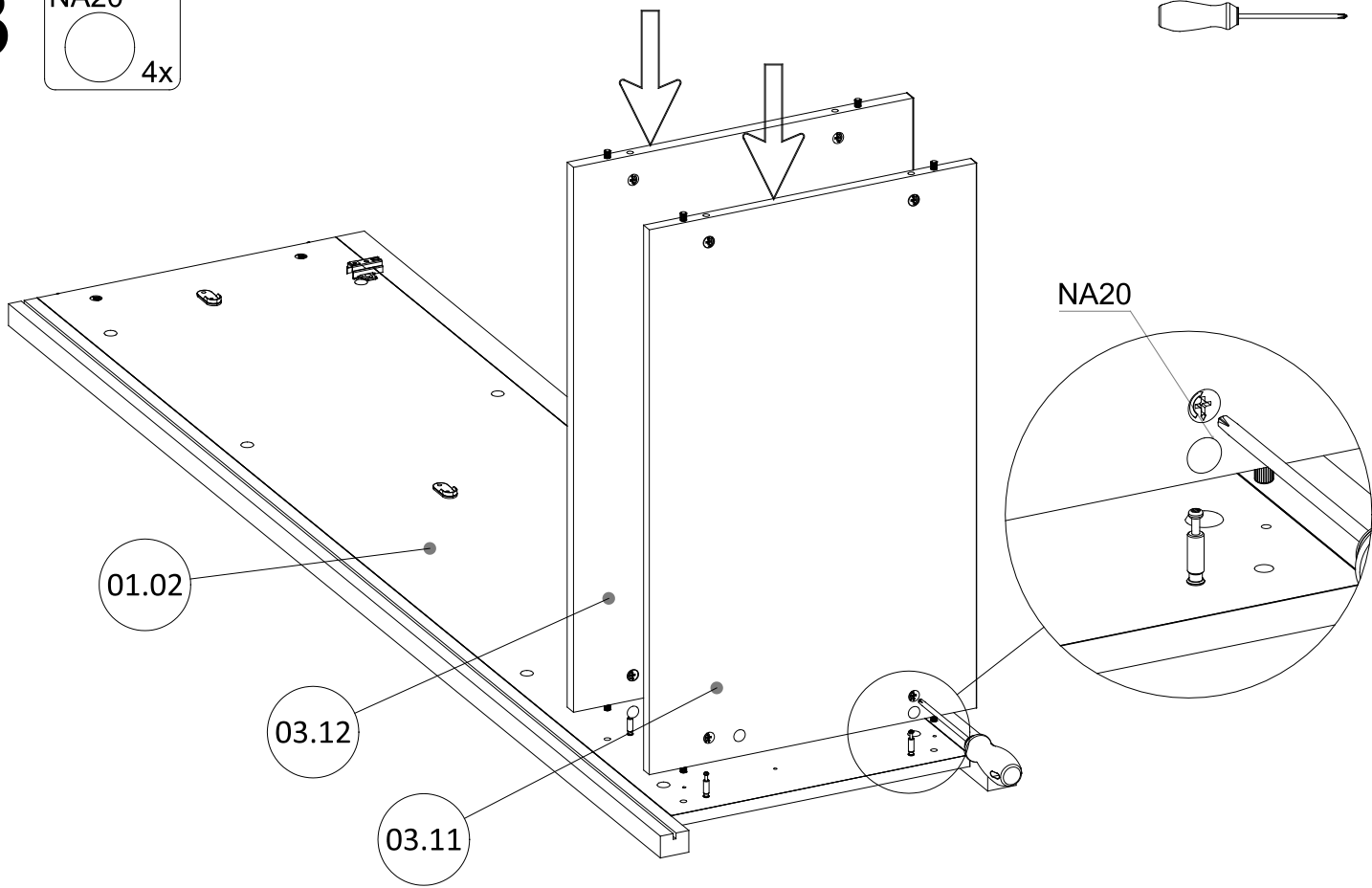
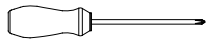

14

NA20
4x

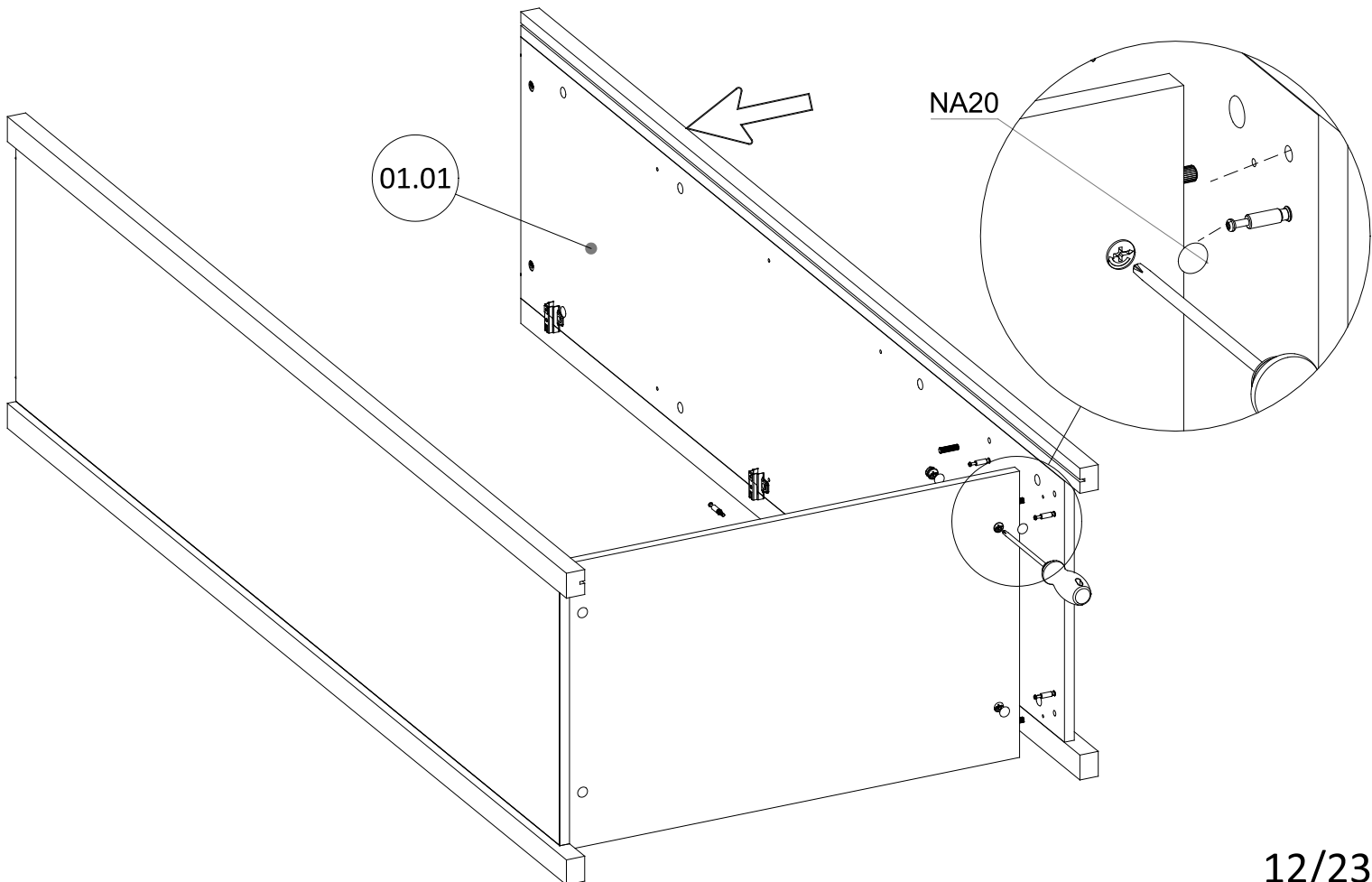
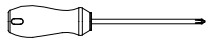

15

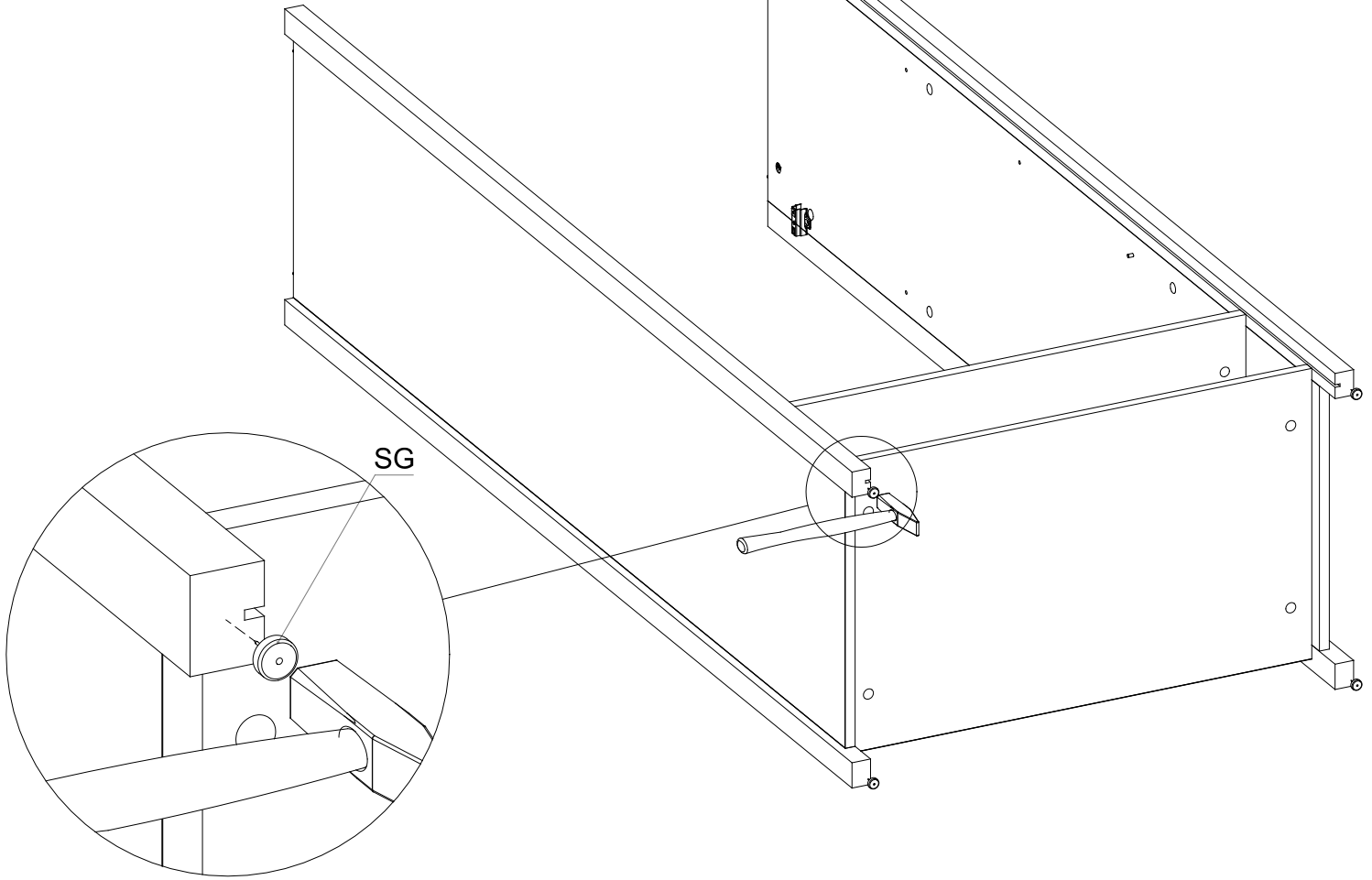
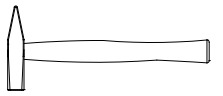
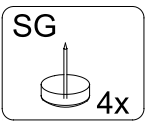

16

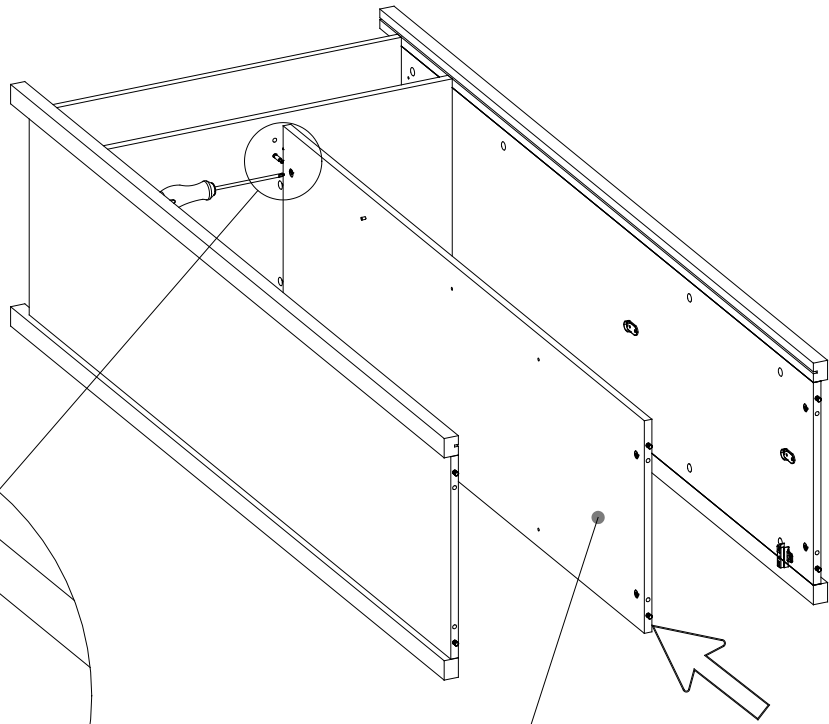
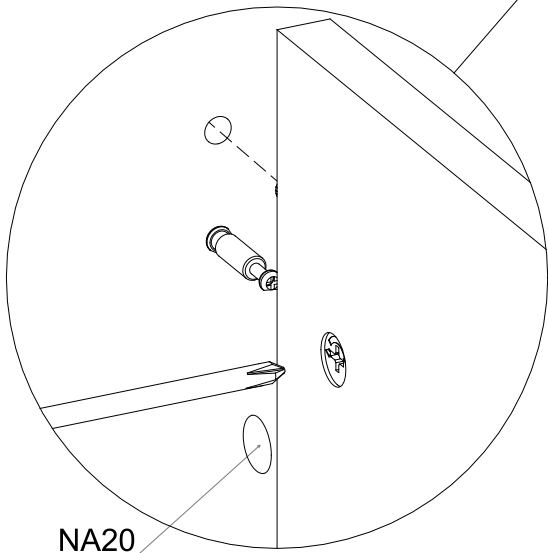
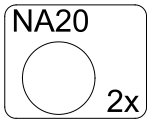

04.11

17

NA20
6x

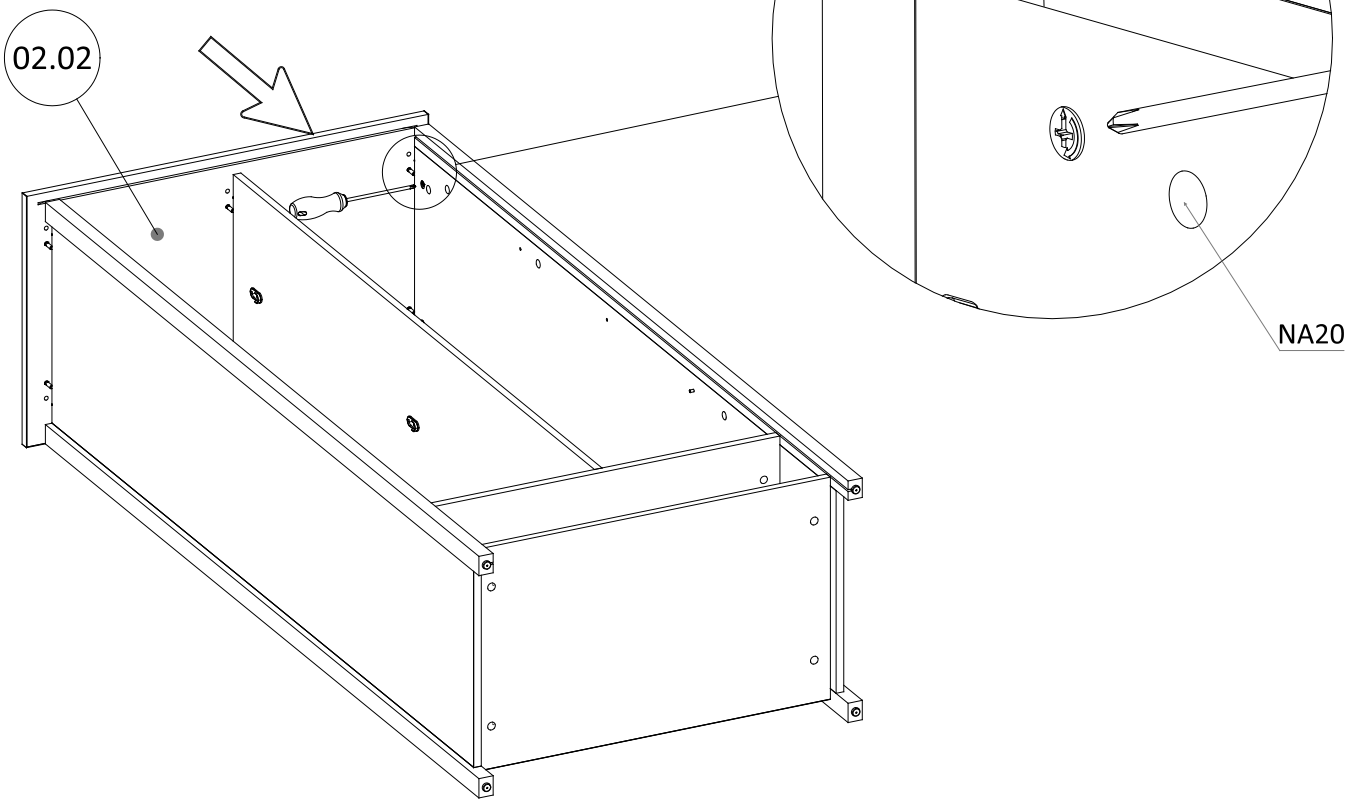
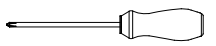

18

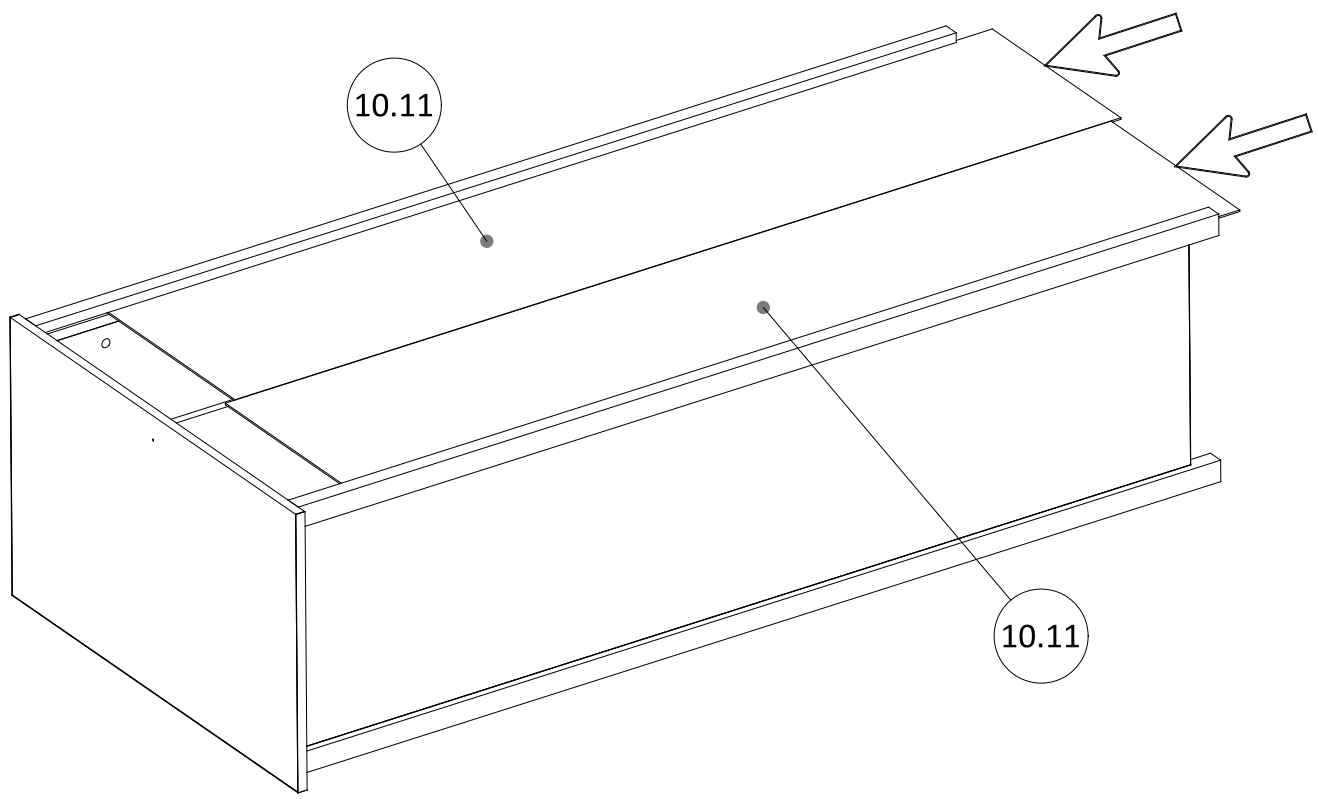

19

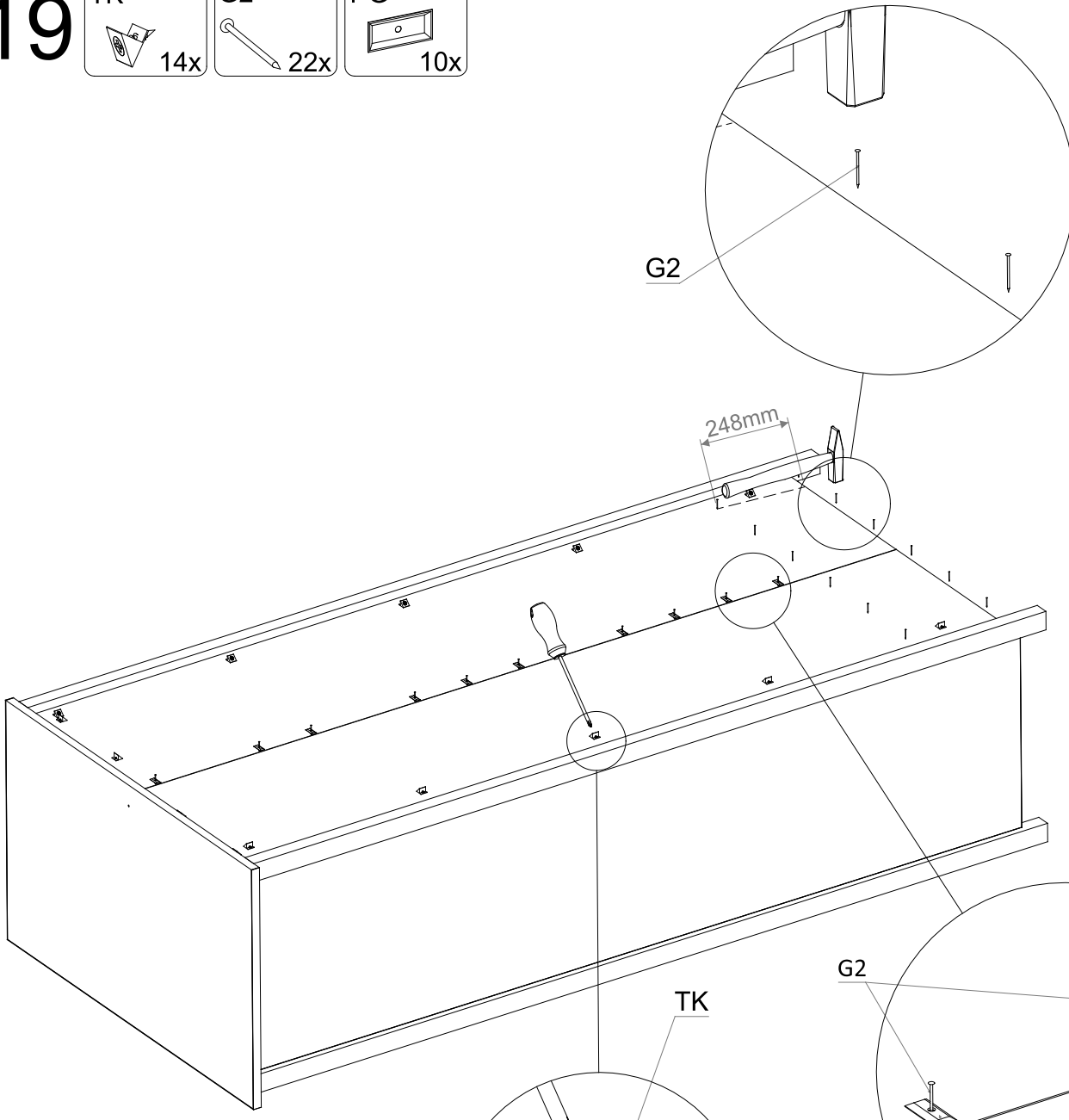
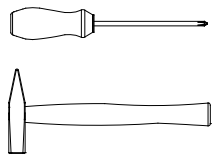
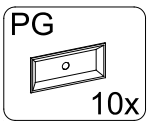
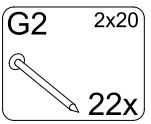
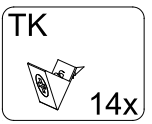

G2

248mm

TK

G2

PG

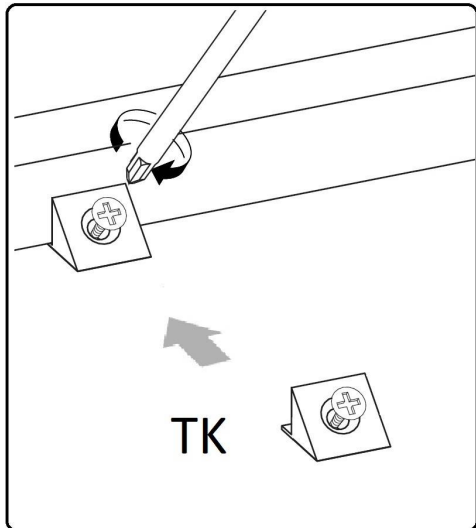

TK

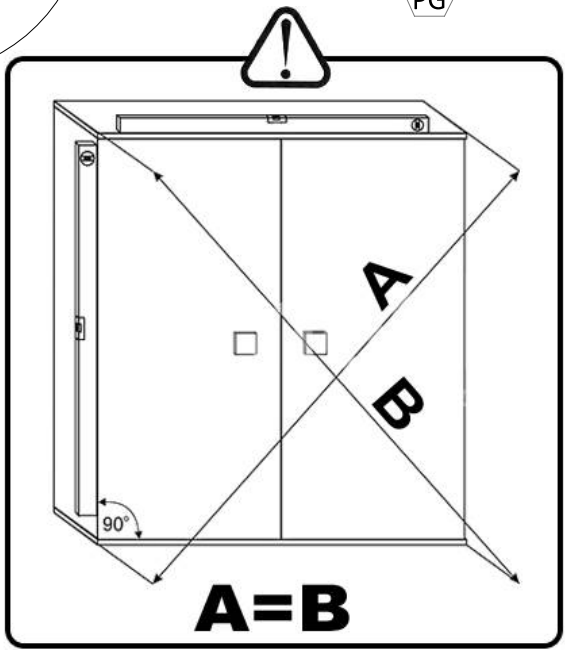

A=B

20

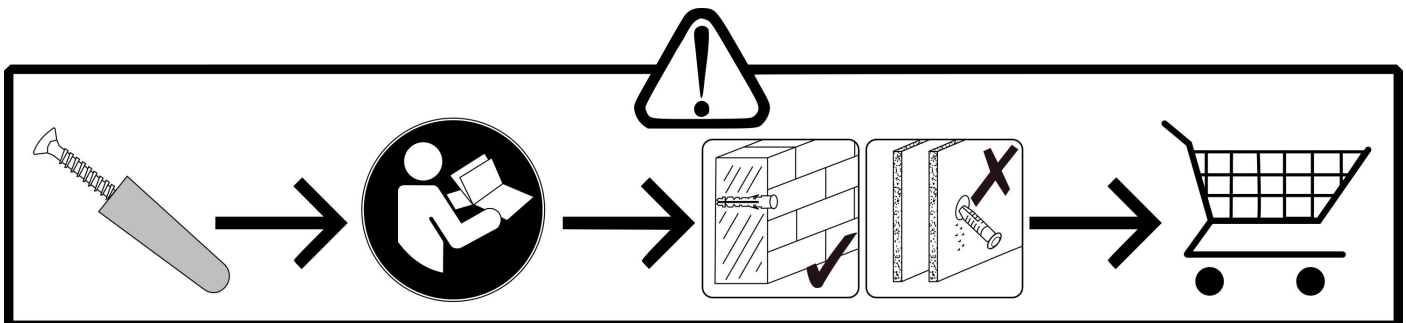
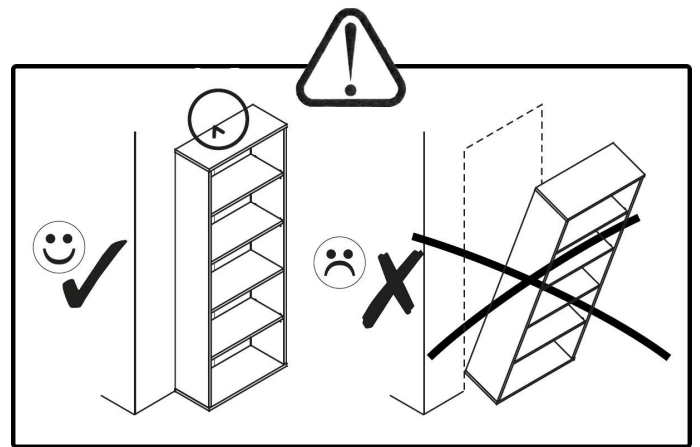
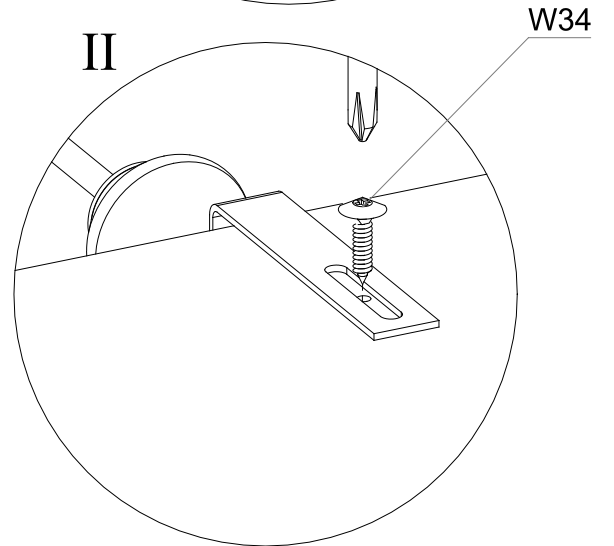
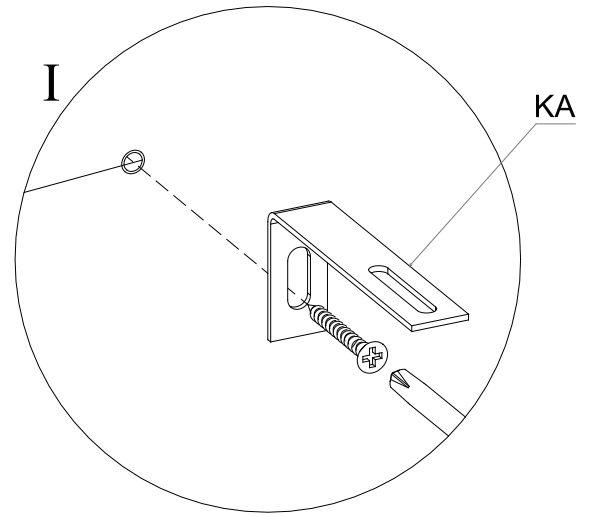
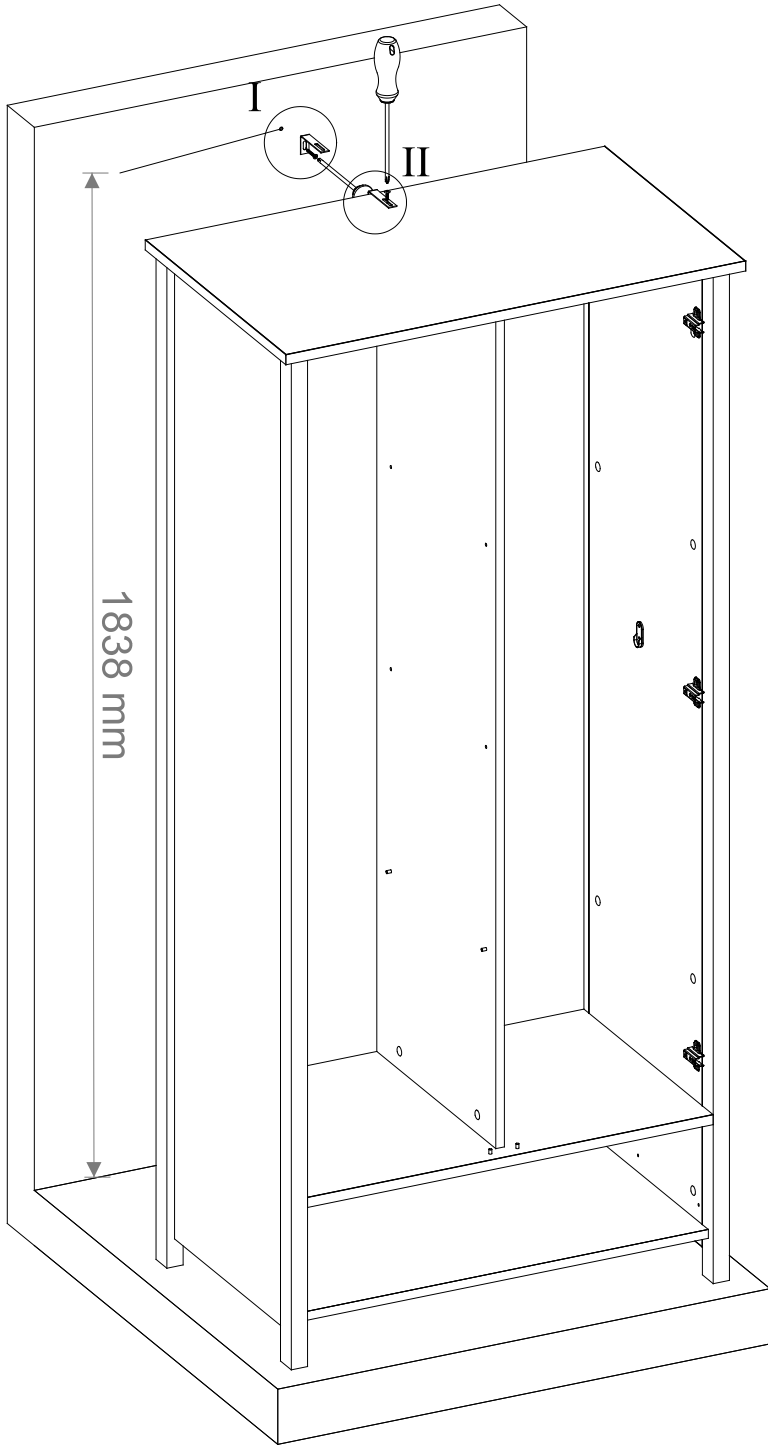
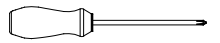
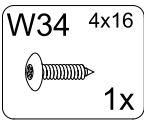
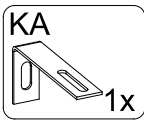

21

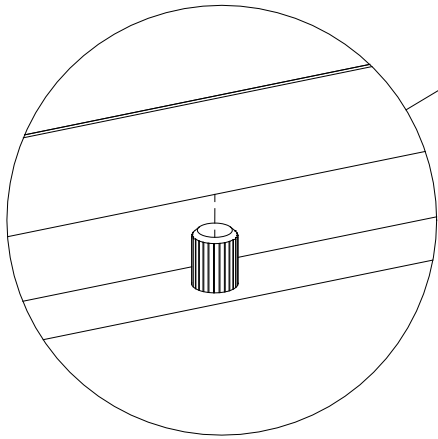
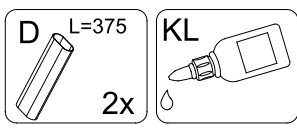

05.11

05.11

05.11

07.21

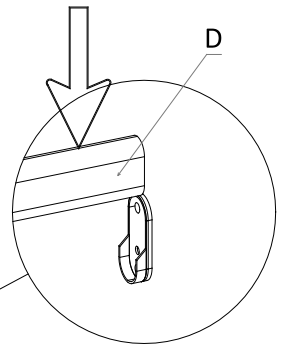
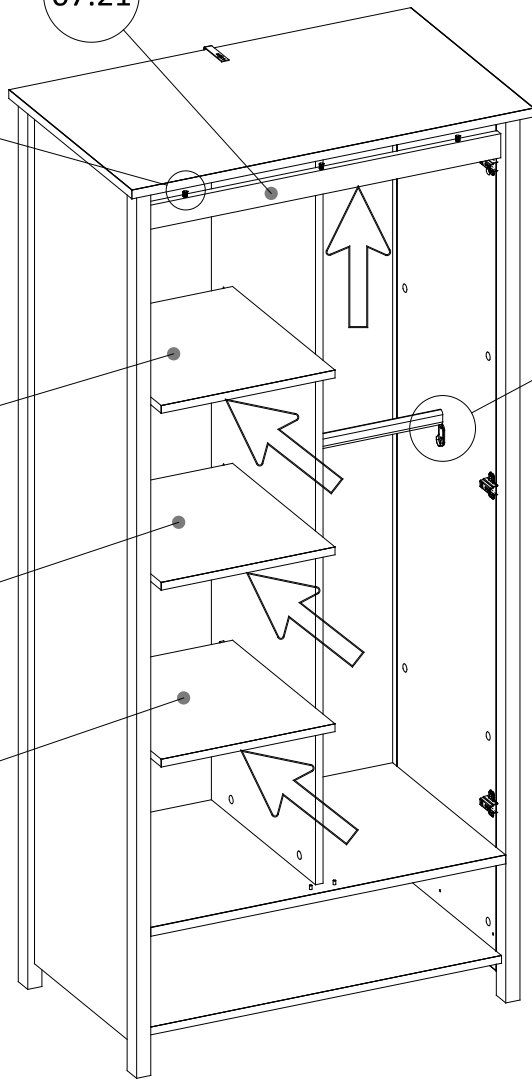

22

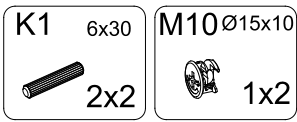

2x

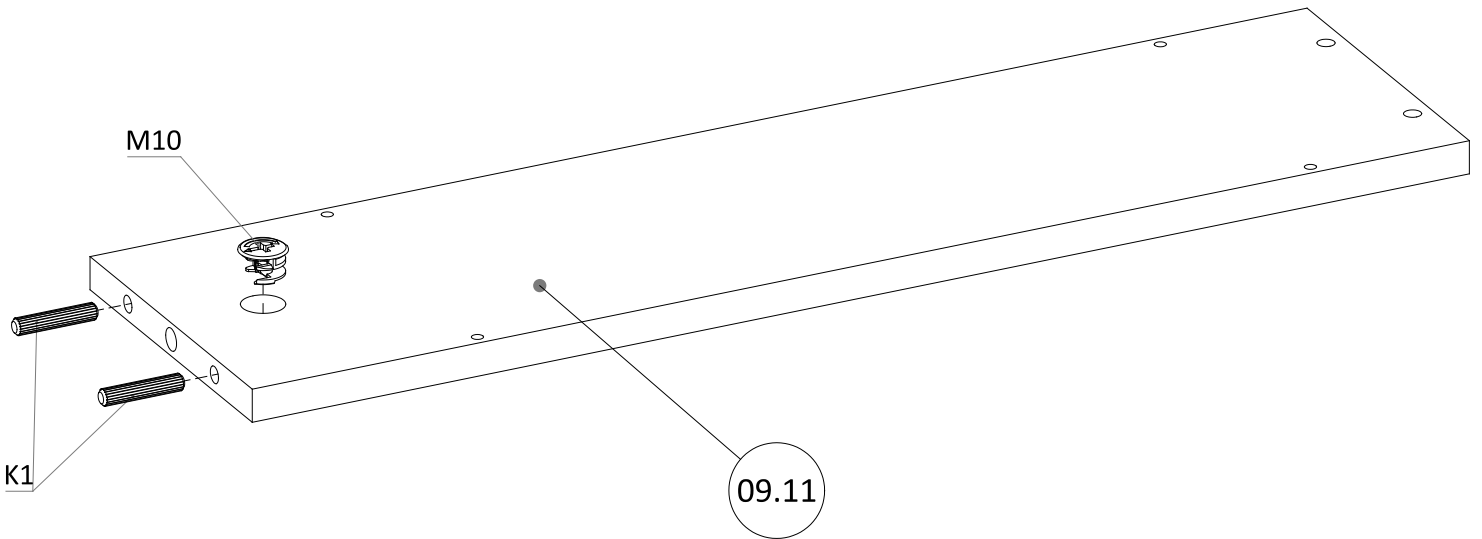

23

KP 6x40
4x

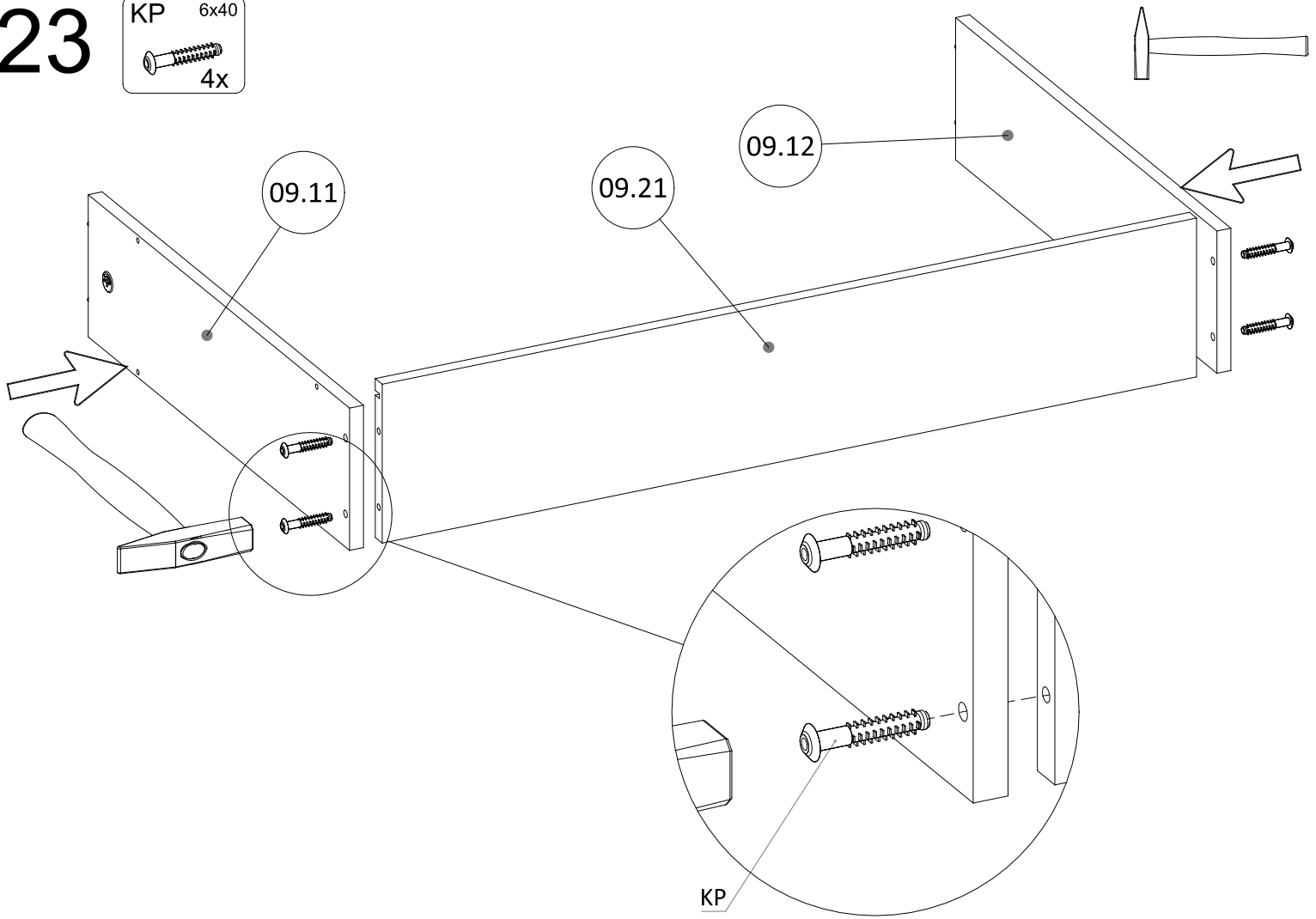

24

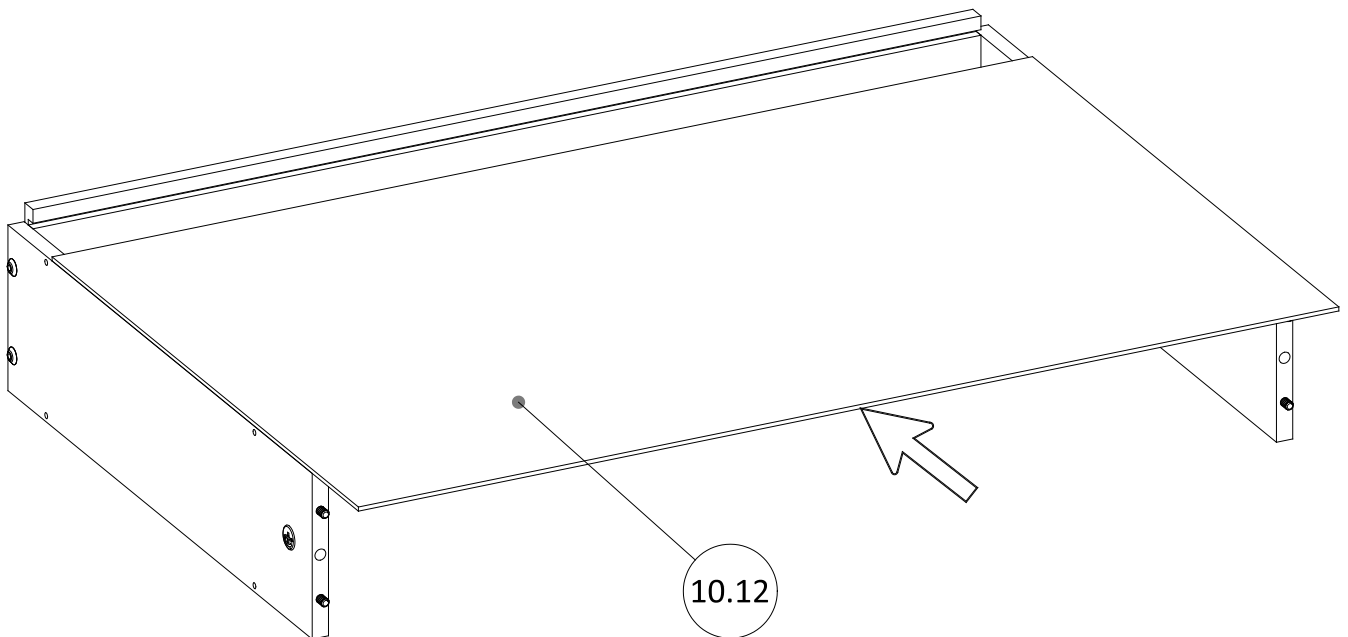

25

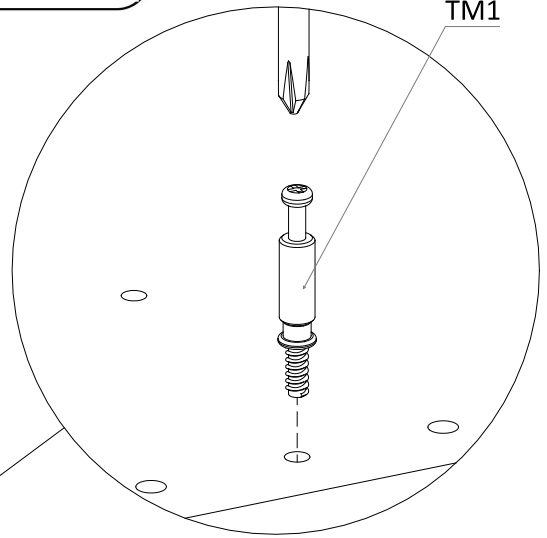
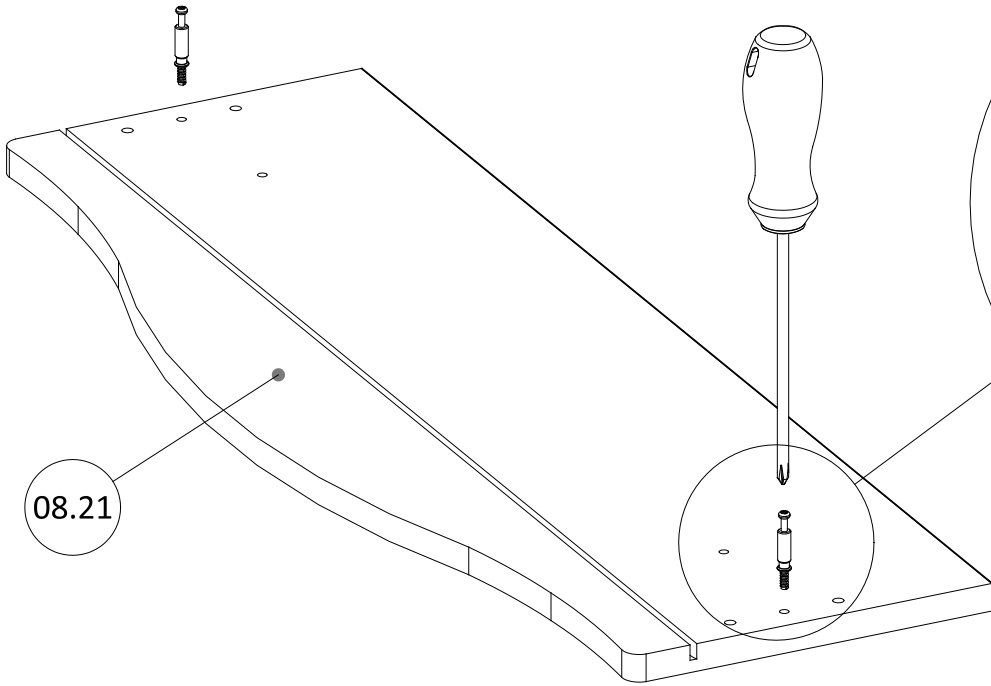
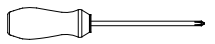
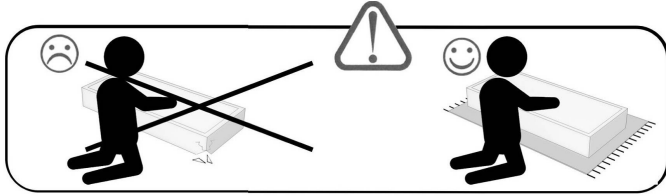
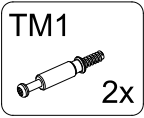

26

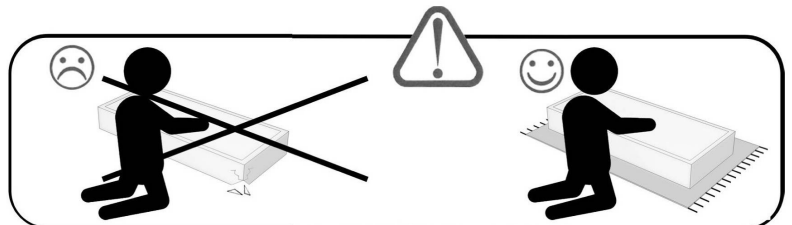
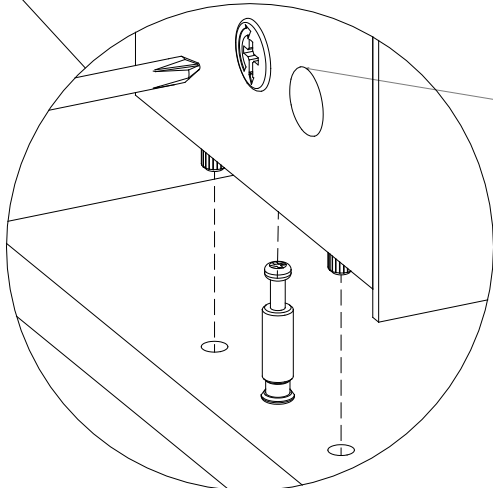
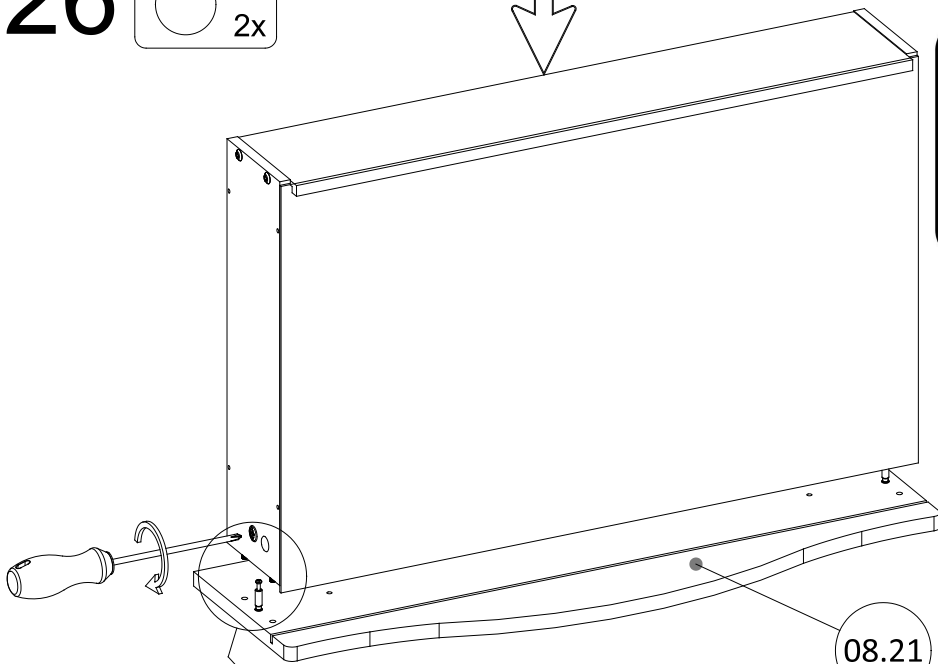
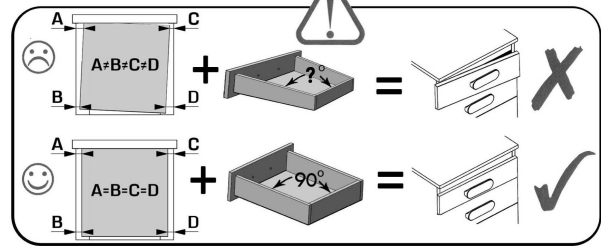
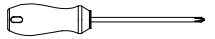
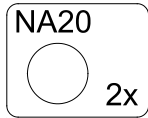

27

- PR5 2x
- WE66 5x9 4x

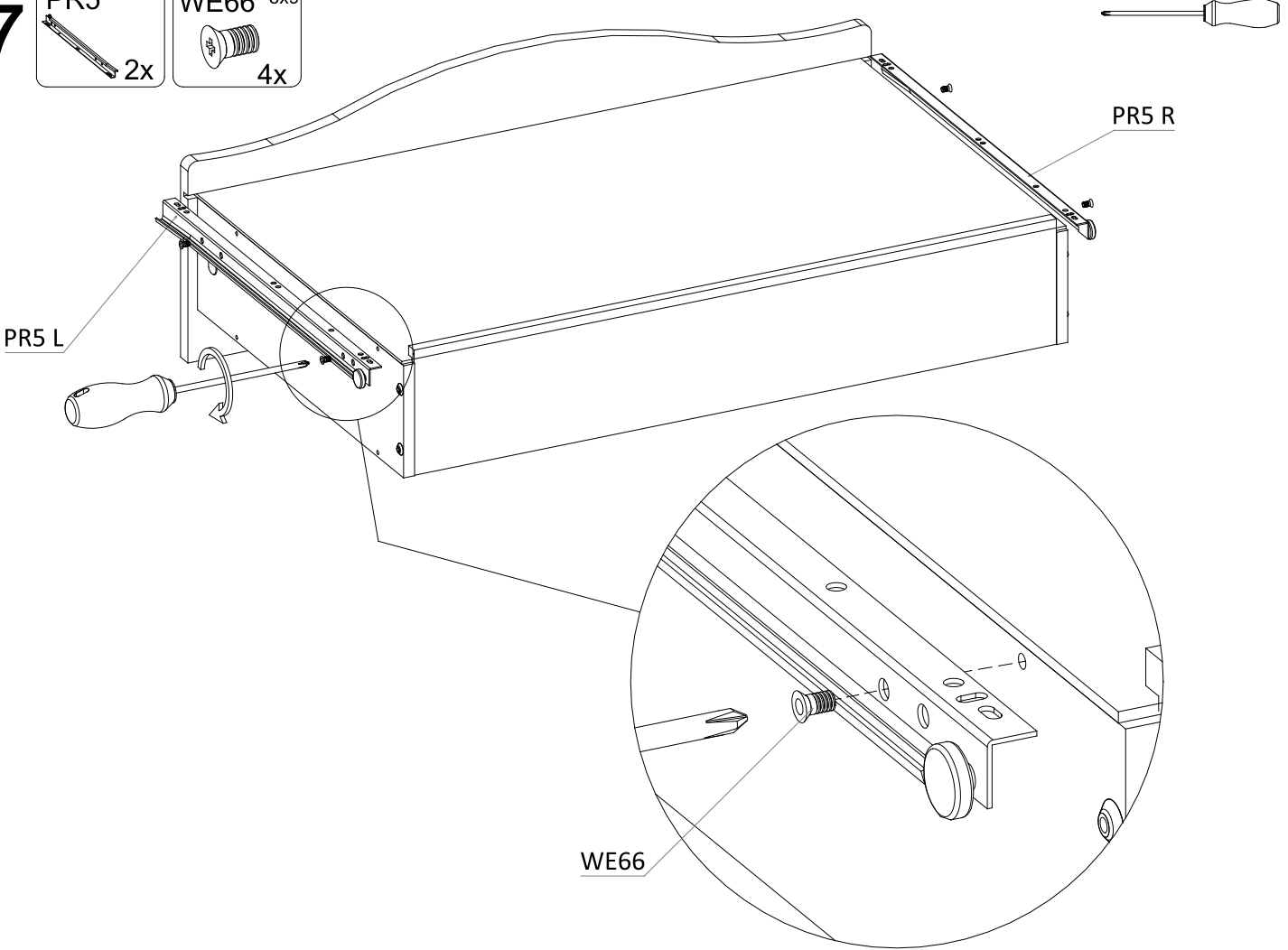

28

- U2 Ø26 2x
- S42 M4x24 2x

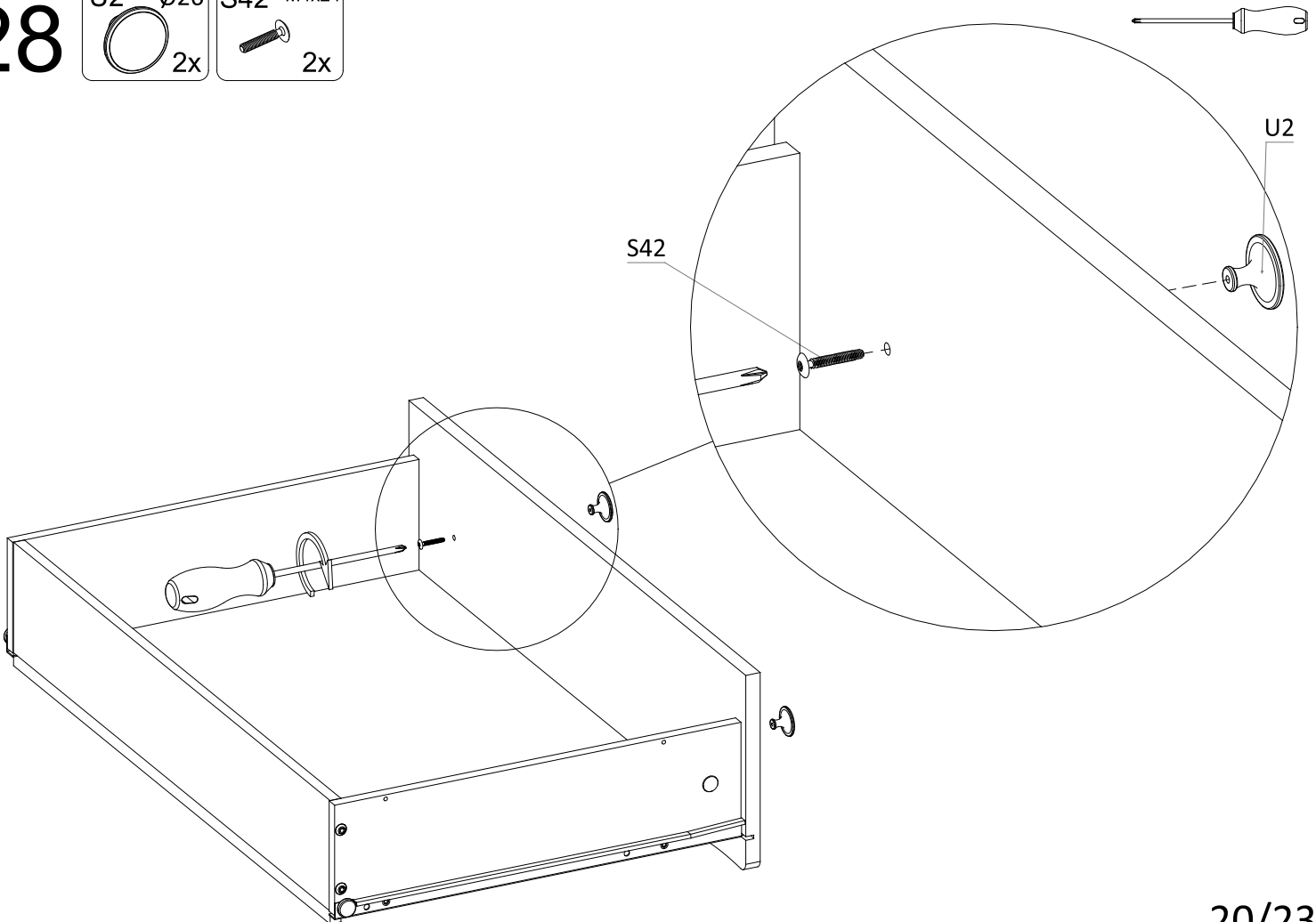

29

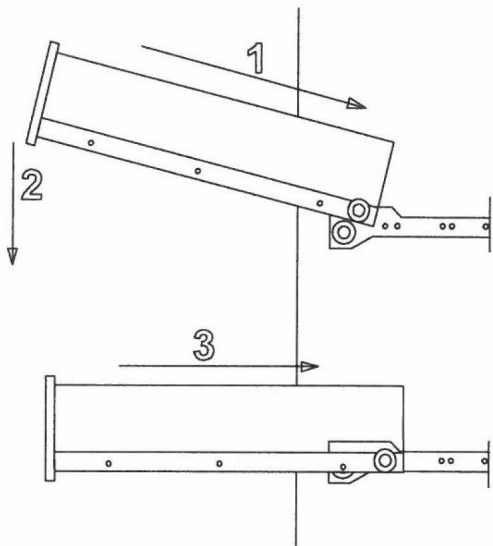
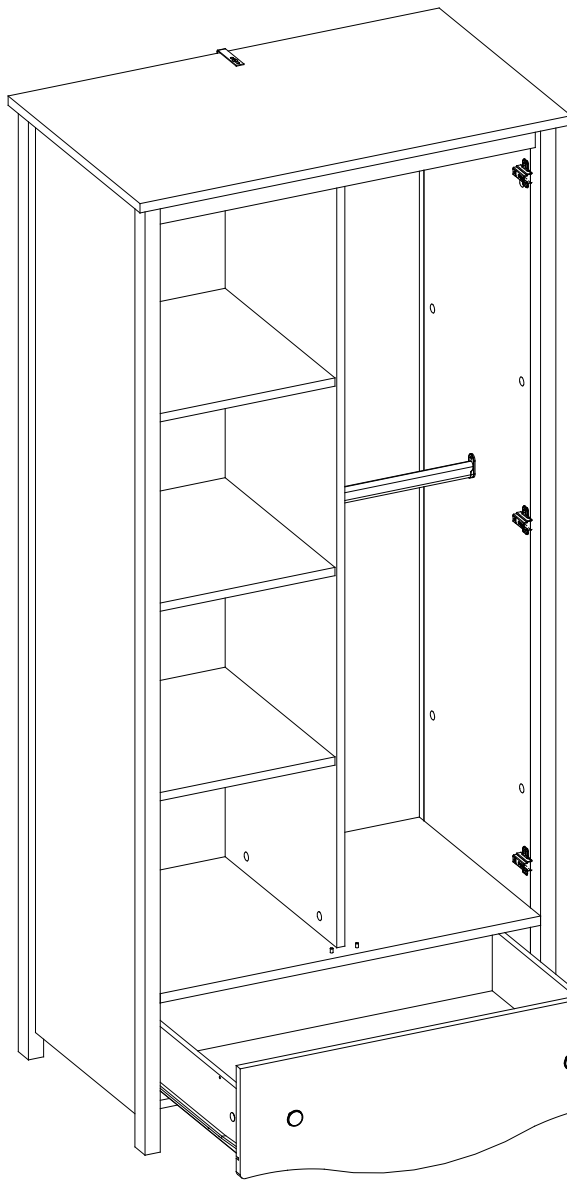

08.21

30

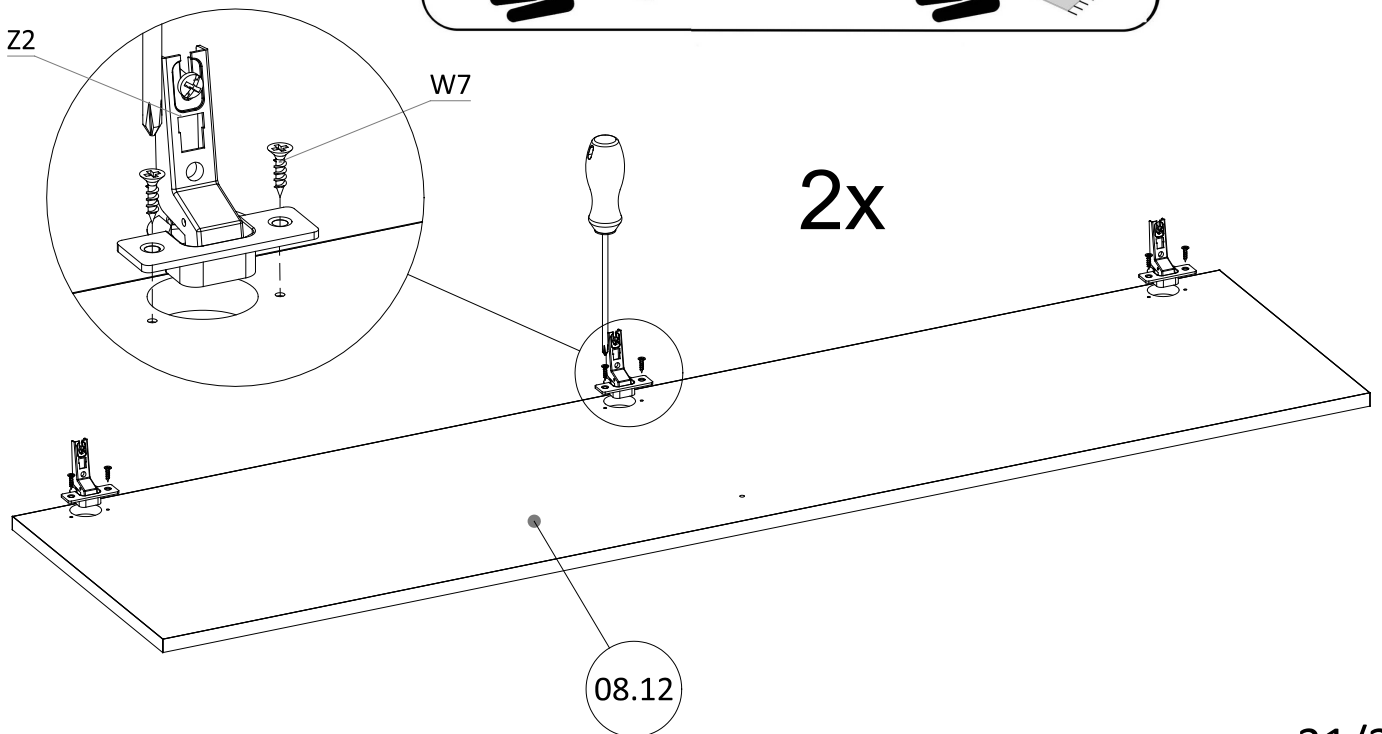
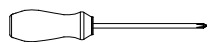
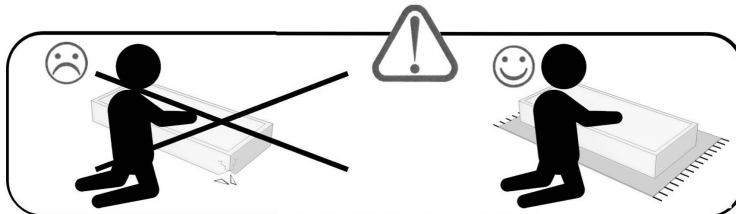

08.12

31

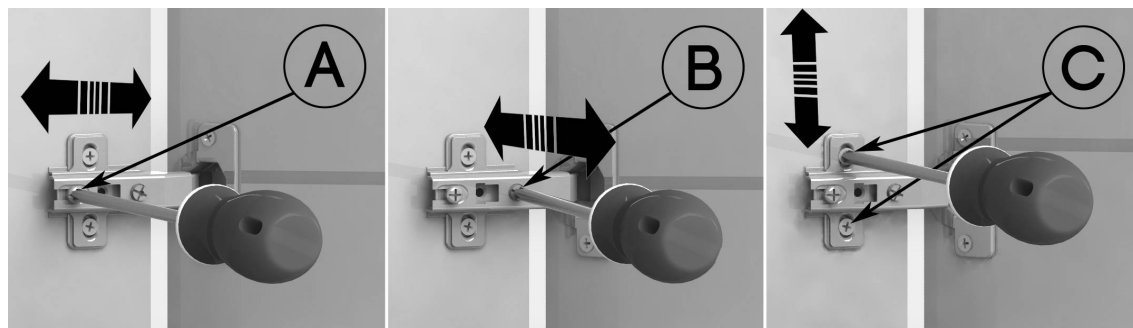
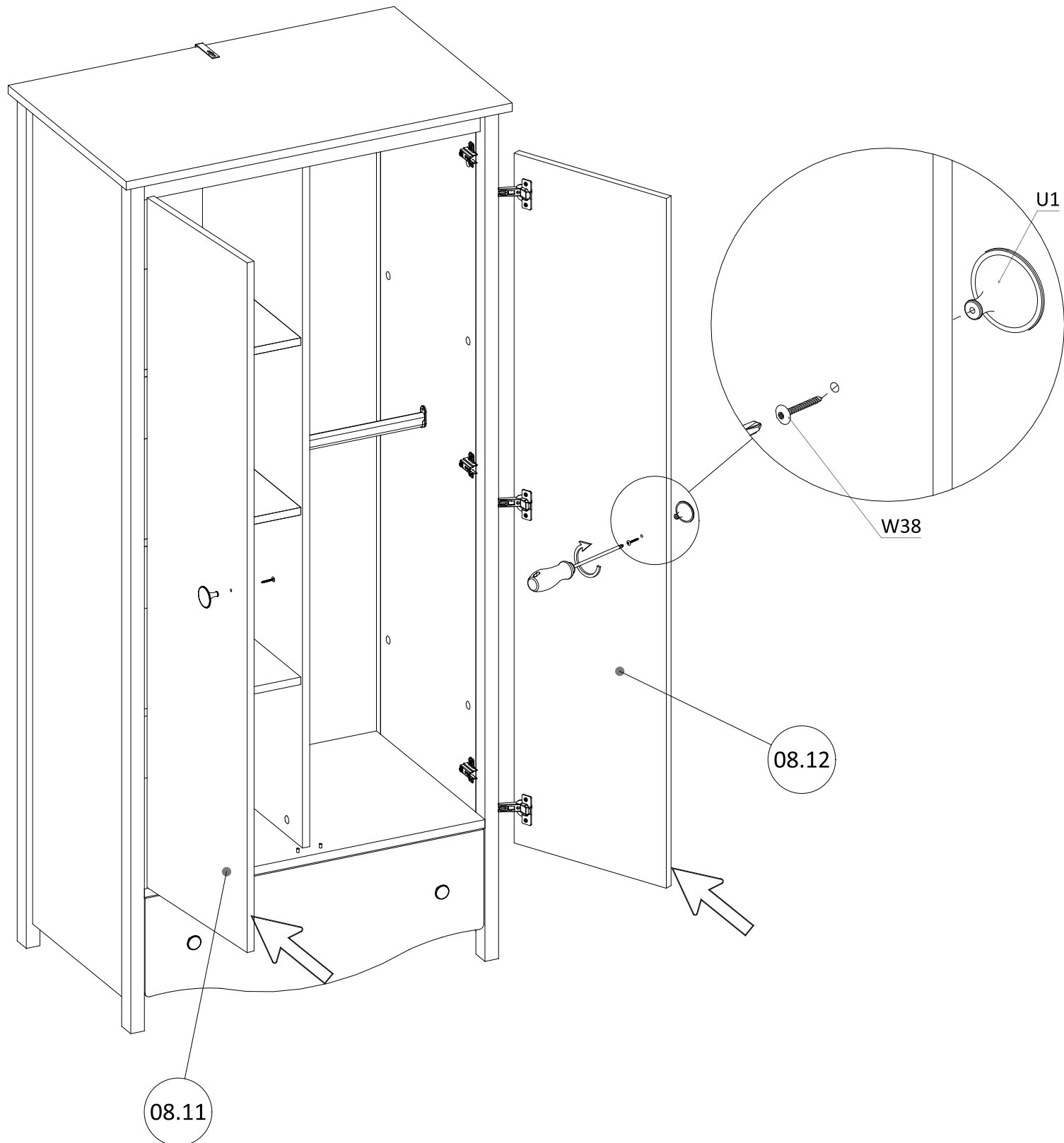
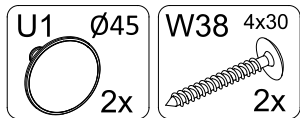

PL

Zasady użytkowania mebli:

1. Meble powinny być użytkowane zgodnie z ich przeznaczeniem.
2. Meble należy użytkować w pomieszczeniach suchych, zamkniętych i zabezpieczonych przed szkodliwymi wpływami atmosferycznym oraz bezpośrednim działaniem promieni słonecznych.
3. Mebli nie należy ustawiać w odległości mniejszej niż pół metra od czynnych grzejników.
4. Wymagane jest równe wypoziomowanie, ustawienie mebli na stabilnym podłożu.
5. Sposób montażu mebli, ilość elementów i akcesoriów niezbędnych do montażu określa karta informacyjna znajdująca się w opakowaniu danego typu mebla. Chyba, że meble zgodnie z życzeniem Klienta zostały dostarczone zmontowane. W tym wypadku instrukcje montażu nie są załączane do mebli.
6. Na powierzchniach mebli nie należy stawiać przedmiotów wilgotnych
7. Po zmontowaniu mebli należy wyregulować drzwi na prowadnicach.

Konserwacja i czyszczenie:

1. Powierzchnie wykonane z laminatu, oraz lakierowane czyścić miękką tkaniną.
2. Do pielęgnacji powierzchni nie należy stosować żadnych środków chemicznych, lub szorstkich ścierek.

Szanowny kliencie, gdyby brakowało jakiejś części, lub byłaby uszkodzona proszę to oznaczyć na instrukcji montażowej i przesłać razem z reklamacją. Jeżeli uszkodzony element będzie zamontowany na stałe reklamacja nie będzie uznana.

CZ

Základy používání nábytku:

1. Nábytek by měl být používán k určenému účelu
2. Nábytek by měl být používán v místnostech suchých, uzavřených a chráněných před škodlivými povětrnostními vlivy a před přímým slunečním zářením.
3. Nábytek by neměl být postaven na méně než půl metru před aktivními radiátory
4. Požadované je umístění nábytku na stabilním, vyrovnaném povrchu.
5. Návod na montáž nábytku, počet součástí a příslušenství nezbytného k montáži je uveden na informačním listu, nacházejícím se v obalu určeného nábytku. V případě, že na přání zákazníka nábytek byl dodán smontovaný, návod k montáži se nepřipojuje.
6. Na povrch nábytku nepokládejte vlhké předměty.
7. Po smontování nábytku seřídít (vyrovnat) dveře pomocí kolejničky.

Údržba a čištění:

1. Povrchy z lamina a lakované čistit měkkým hadříkem.
2. K údržbě povrchu nepoužívejte žádné chemické látky ani hrubé hadříky.

Vážený zákazníku, v případě, že chybí některé části nebo jsou poškozené, označte je v montážních instrukcích a zašlete společně s reklamací. Pokud poškozená část bude na pevně smontována, nebude se na ní vztahovat reklamacie.

DE

Regeln der Möbelbenutzung:

1. Die Möbel sollten entsprechend ihrer Bestimmung verwendet werden.
2. Die Möbel sollten in trockenen, geschlossenen und gegen den schädlichen Witterungseinfluss sowie die direkte Wirkung der Sonnenstrahlen geschützten Räumen benutzt werden.
3. Die Möbel sollen von den tätigen Heizkörpern mindestens ein halbes Meter entfernt werden.
4. Es ist erforderlich, dass der Grund, wo die Möbel stehen, gut nivelliert und stabil ist.
5. Die Art und Weise der Montage, Anzahl der Bauteile und die Ausstattung, die für die Montage unentbehrlich ist, bestimmt die Infokarte, die sich in der Verpackung des jeweiligen Möbelstückes befindet. Es sei denn, die Möbel wurden nach dem Wunsch des Kunden im zusammengebauten Zustand zugeliefert. In einem solchen Fall werden die Montageanweisungen nicht hinzugefügt.
6. Auf der Oberfläche der Möbel darf man keine feuchten Gegenstände stellen.
7. Nach dem Zusammenbauen der Möbel sollte man die Tür an den Führungen richten.

Wartung und Sauberhaltung:

1. Flächen aus Laminat und lackierte Oberflächen sind mit einem weichen Tuch zu reinigen.
2. Zur Pflege der Oberfläche sollten keine chemischen Mitteln oder borstigen Wischtücher verwendet werden.

Sehr geehrter Kunde, sollte ein Bauteil fehlen oder geschädigt werden, kennzeichnen Sie dies bitte auf der Montageanweisung und zusammen mit dem Beschwerdebrief senden. Sollte das geschädigte Teil fest angebaut werden, wird die Beanstandung nicht anerkannt.

EN

Terms of use furniture:

1. Furniture should be used for their intended purpose.
2. Furniture should be used in dry, closed rooms, protected from an adverse weather and a direct sunlight.
3. Furniture should not be set at a distance of less than half a meter of active radiators.
4. The equal leveling is required and the need to set furniture on the stable base.
5. The information card, contained in the packaging of the given type of furniture, defines the assembling method of furniture, quantity of components and accessories necessary for assembly. Except when furniture were delivered assembled according to the customer wish. Assembly instructions are not attached to furniture in this case.
6. Wet objects should not be placed on surfaces of furniture.
7. Doors on tracks should be adjusted after assembling furniture.

Maintenance and cleaning:

1. Surfaces made of the laminate and lacquered surfaces clean with a soft cloth.
2. Any chemicals or rough rubbers should not be used for the surfaces care.

Dear customer, if anything part is missing or damaged, mark it on the assembly instruction and sent together with the claim, please. If the damaged item is permanently mounted, than the complaint will not be considered.

SK

Základy používania nábytku:

1. Nábytok používajte k určenému účelu.
2. Nábytok používajte v suchej, uzatvorenej a chránenej pred škodlivými poveternostnými vplyvmi miestnosti, chráňte pred priamym slnečným žiarením.
3. Nábytok by nemal byť postavený na menej než pol metra pred aktívnymi radiátormi
4. Nábytok postavte na stabilný, vyrovnaný povrch.
5. Návod na montáž nábytku, počet súčastí a príslušenstva nevyhnutného k montáži, je uvedený na informačnom liste nachádzajúcom sa v obale určeného nábytku. V prípade, že na prianie zákazníka bol nábytok dodaný zmontovaný, nebude návod súčasťou balenia.
6. Na povrch nábytku, nepokladajte vlhké predmety.
7. Po zmontovaní nábytku nastavte dvere pomocou koľajnice.

Údržba a čistenie:

1. Povrchy z lamina a lakované čistit mäkkou handričkou.
2. Pre údržbu povrchu nepoužívejte žiadne chemické látky ani hrubé handričky.

Vážený zákazník, v prípade, že chýbajú niektoré časti, alebo sú poškodené, označte ich v montážnych inštrukciách a pošlite spoločne s reklamáciou. Pokiaľ poškodená časť bude napevno zmontovaná, nebude sa ňu reklamácia vzťahovať.

RU

Правила ухода за мебелью:

1. Мебелью необходимо использовать в соответствии с ее функциональным назначением.
2. Мебель должна эксплуатироваться в сухих, закрытых и защищенных от воздействия атмосферных условий и прямых солнечных лучей помещениях.
3. Мебели нельзя устанавливать ближе 50 см от отопительных приборов.
4. Требуется установка мебели по уровню на стабильной поверхности.
5. Способ монтажа мебели, количество элементов необходимых для монтажа определяет инструкция находящаяся в упаковке данного типа мебели. В случае, если мебель по желанию Клиента была поставлена собранной, инструкция монтажа не прилагается.
6. Нельзя ставить на мебель влажные предметы.
7. После монтажа мебели необходимо отрегулировать дверь на петлях.

Рекомендации по уходу и очистке:

1. Поверхности из ламината и покрытые лаком очищать мягкой тканью.
2. Для ухода за поверхностью не использовать никаких химических средств или шероховатых тряпок.

Уважаемый Клиент, в случае если не хватает какого-нибудь элемента или он поврежден, просим обозначить его на инструкции монтажа и отправить нам вместе с претензией. Если поврежденный элемент будет установлен – претензия не будет признана.