

MARSYLIA

SZAFKA NOCNA

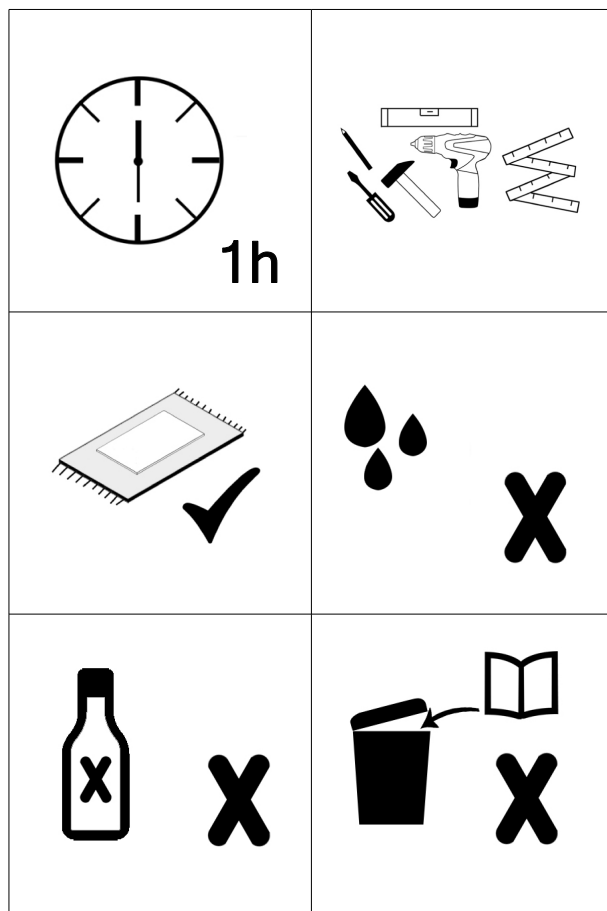
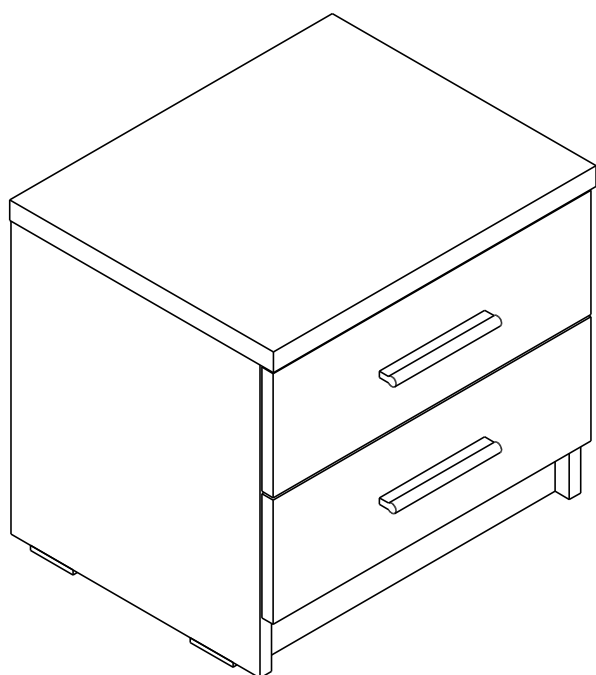

A 12	B 12	C 12	D 10
E 2	F 4	G 4	H 20
J 20	K 4	L 1	M 3

	WYMIARY ELEMENTÓW
-1-	453x370
-2-	382x350
-3-	382x350
-4-	418x336
-5-	418x70
-6-	440x319
-7-	2x 446x151
-8-	2x 300x120
-9-	2x 300x120
-10-	2x 360x100
-11-	2x 380x310

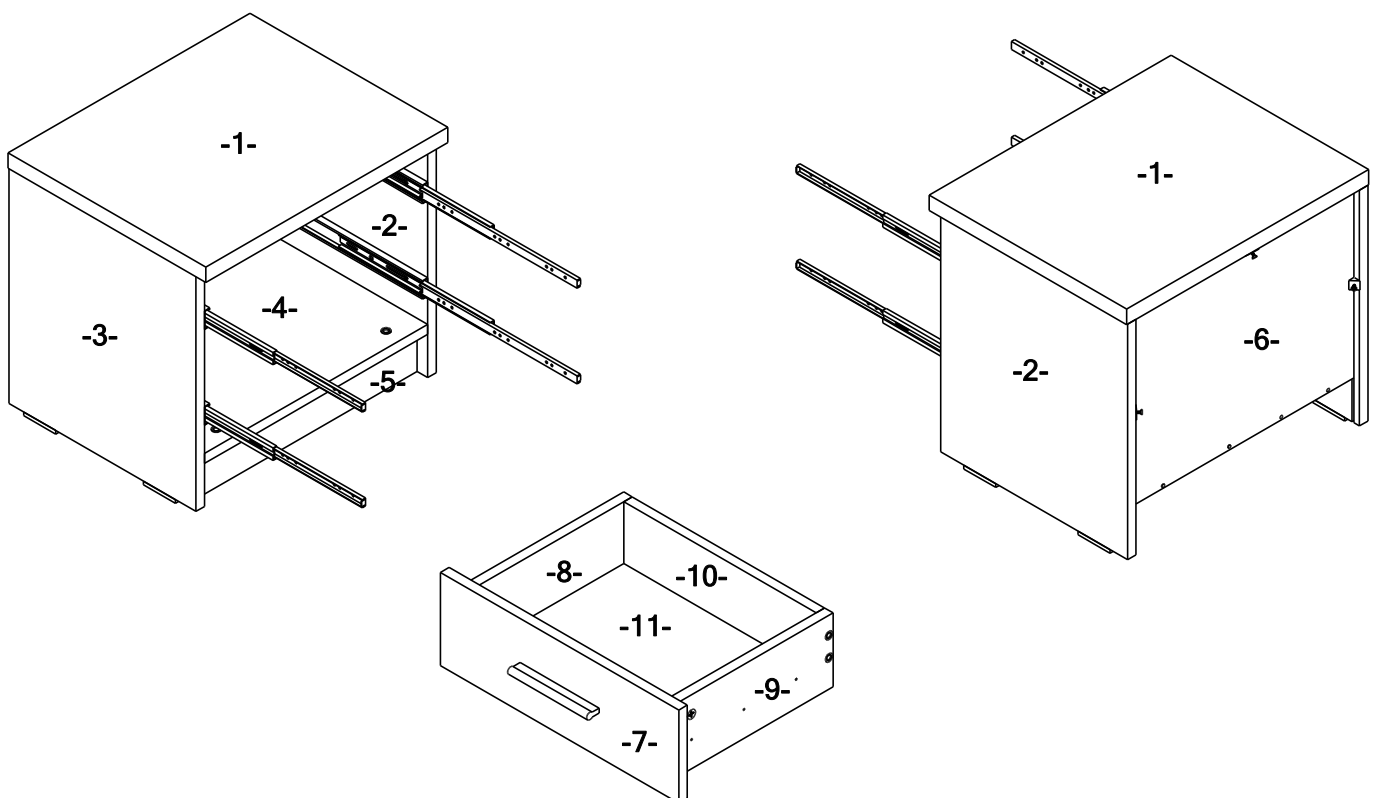

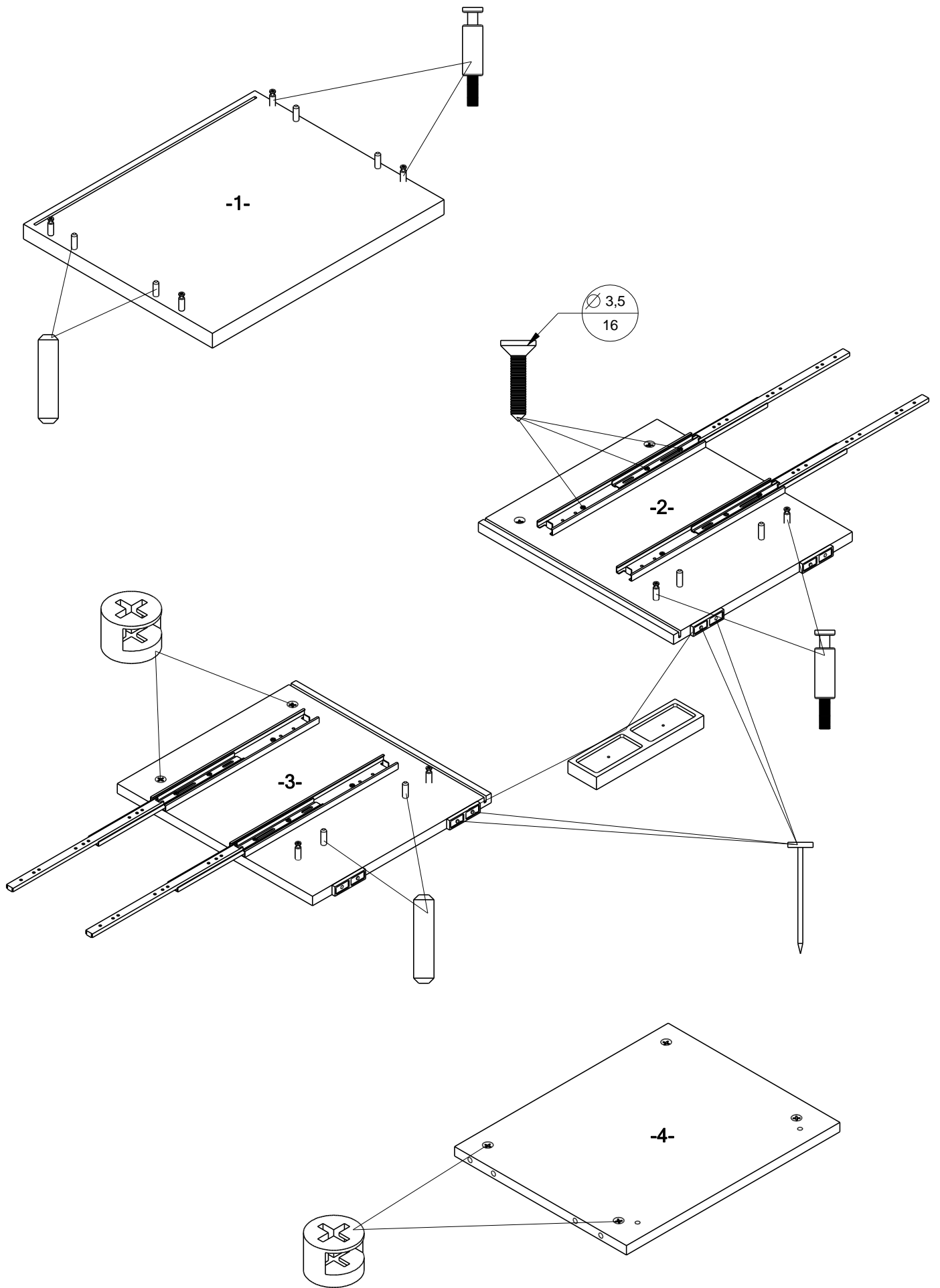

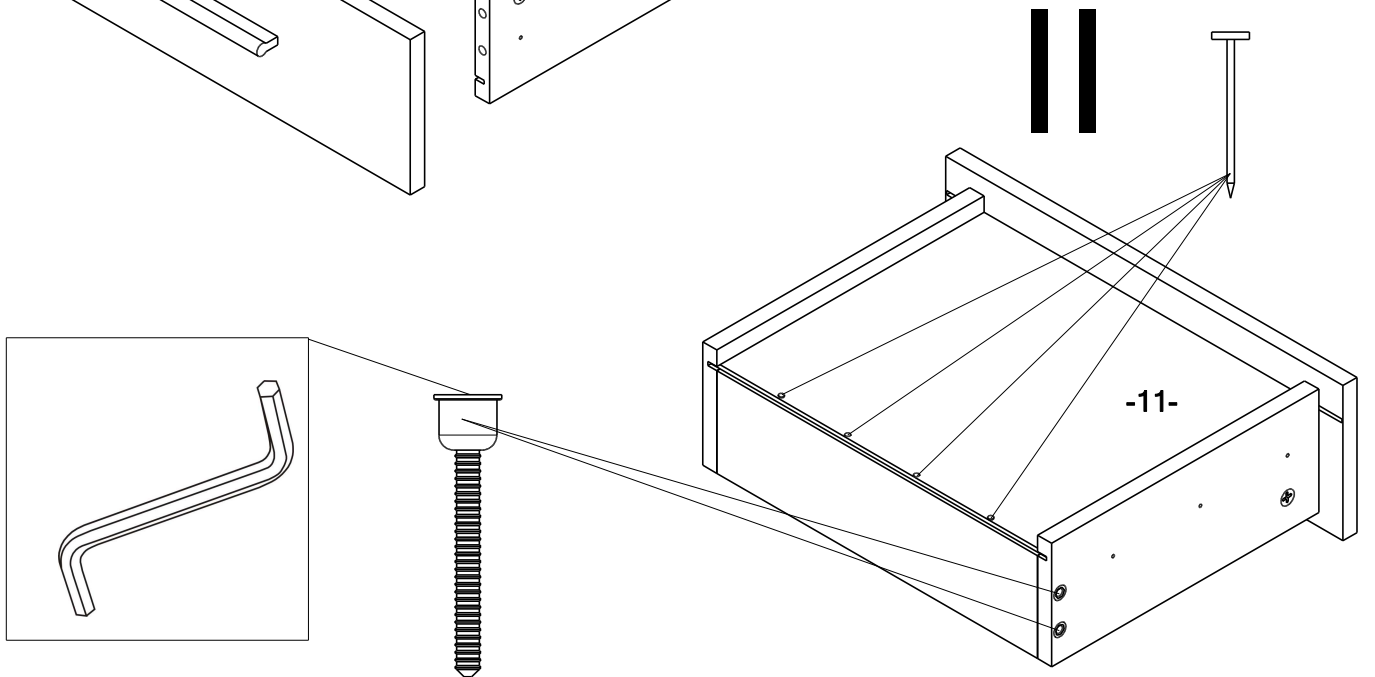
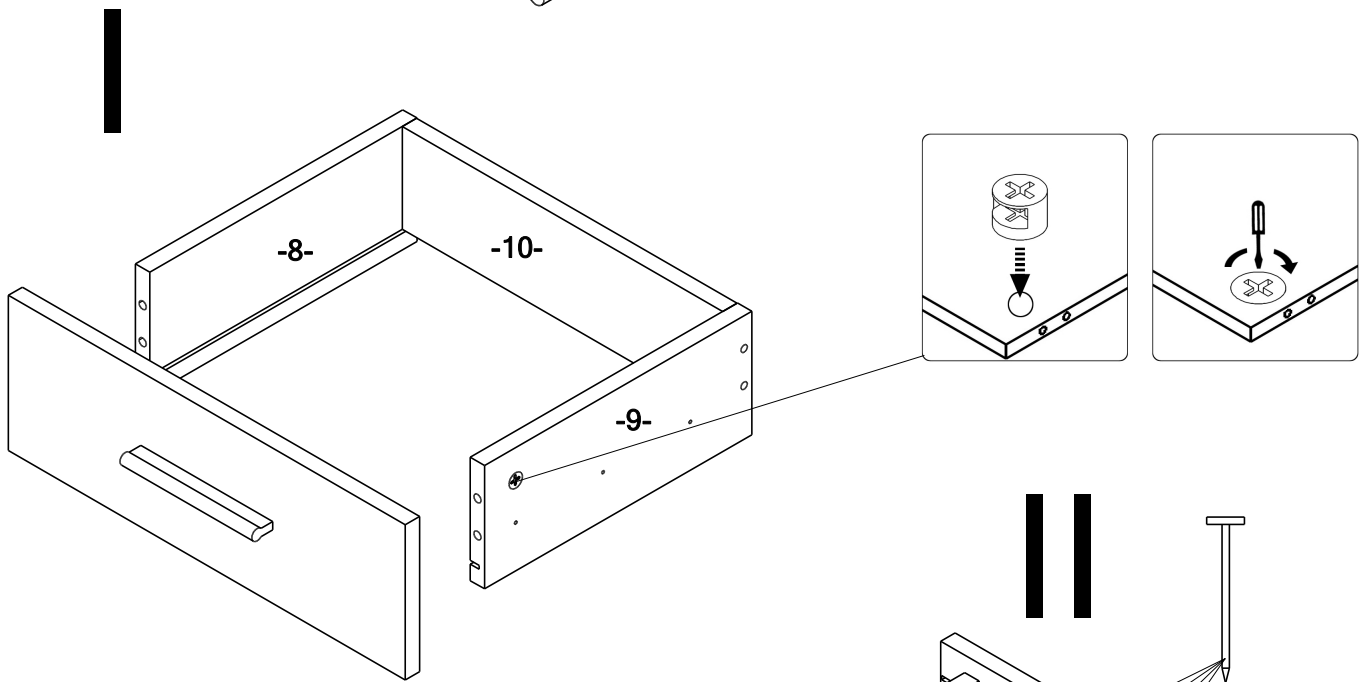
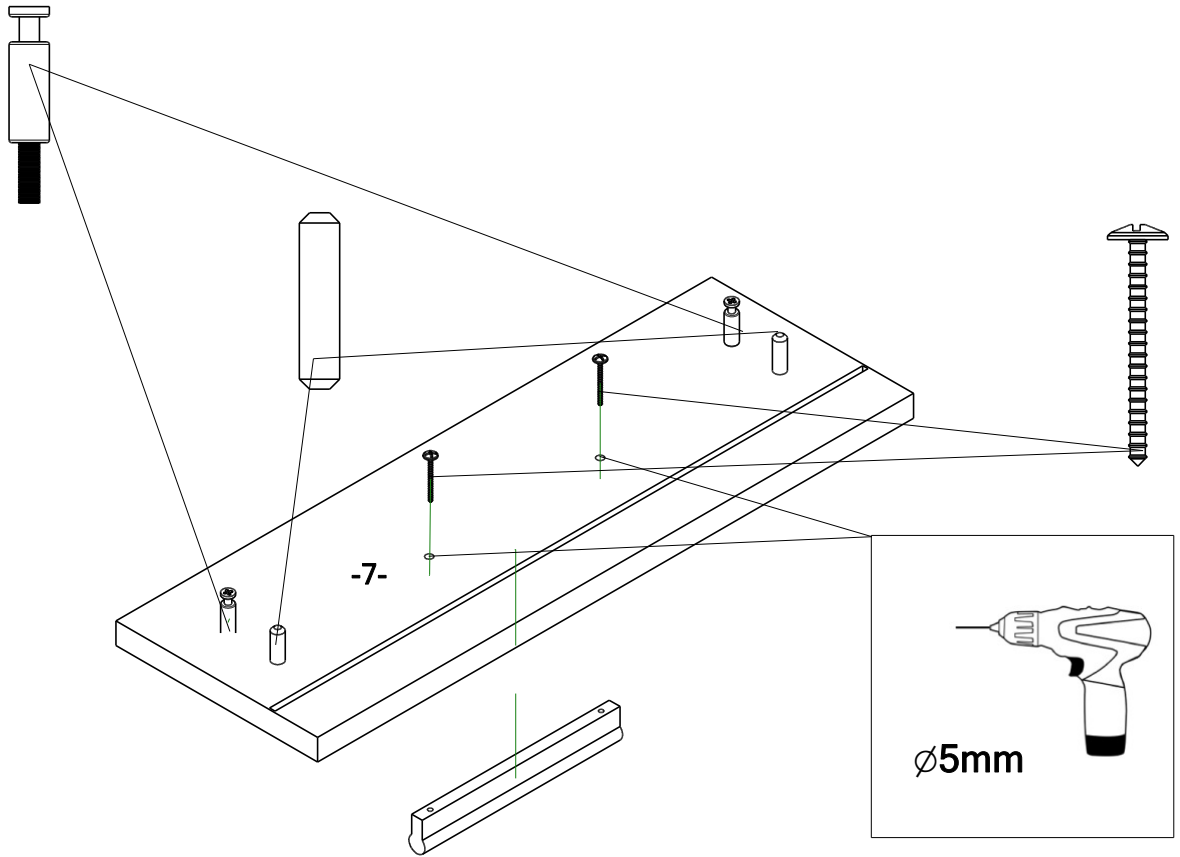

III

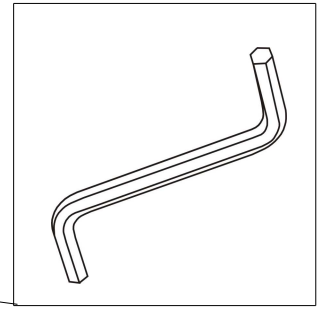
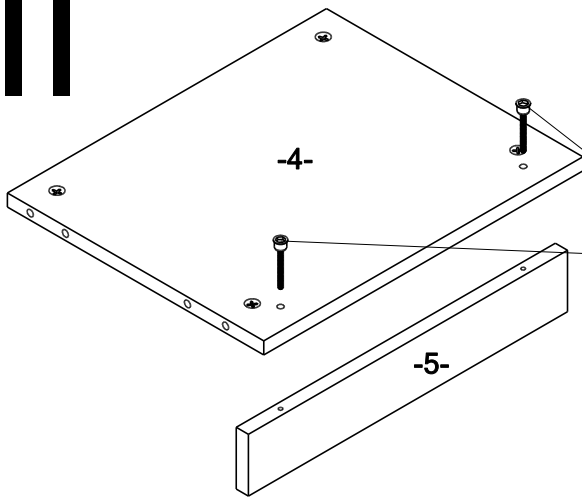

IV

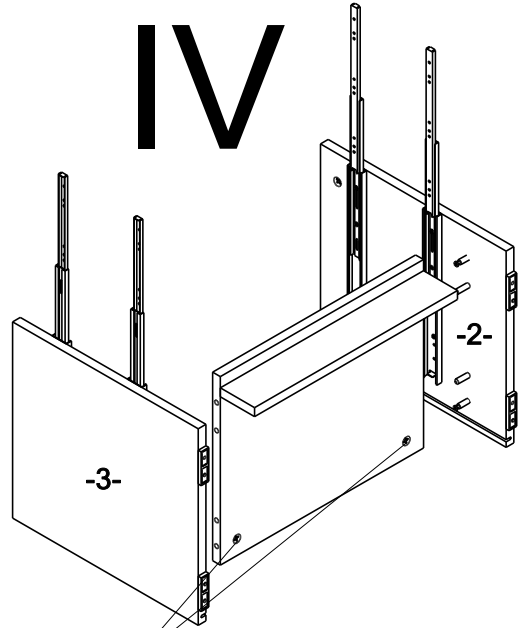

V

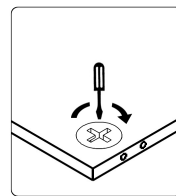
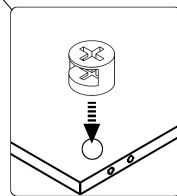
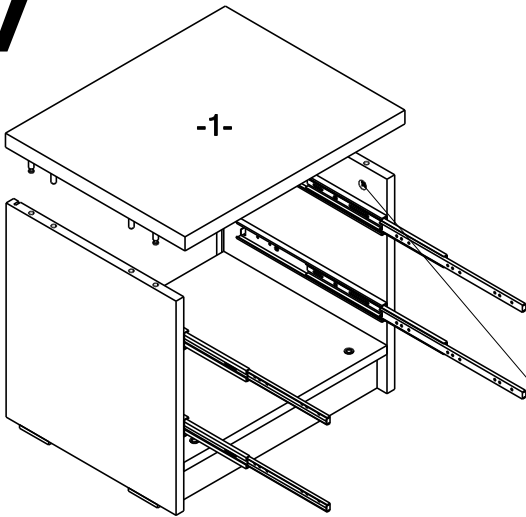

VI

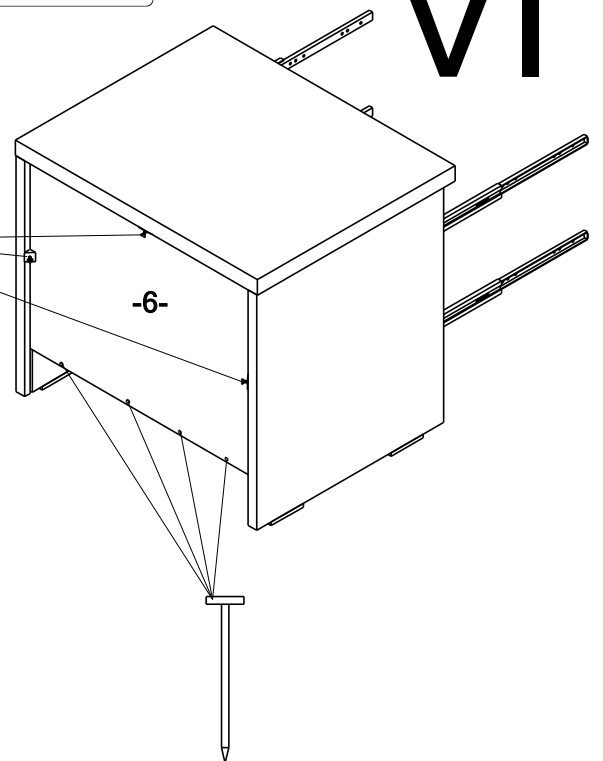

VII

