

# Instrukcja montażu mebli

## «DOORSET»

Szafa 2d2s

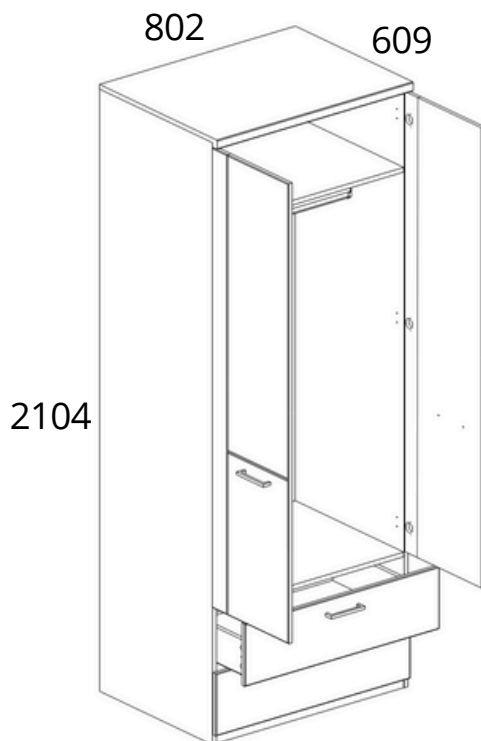

---

Production date  
Data produkcji

---





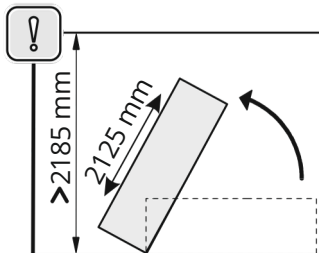
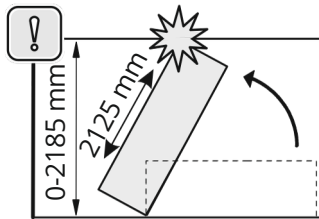

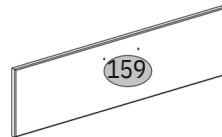
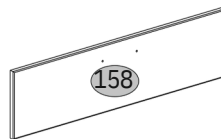
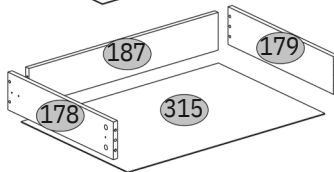
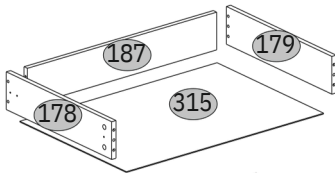
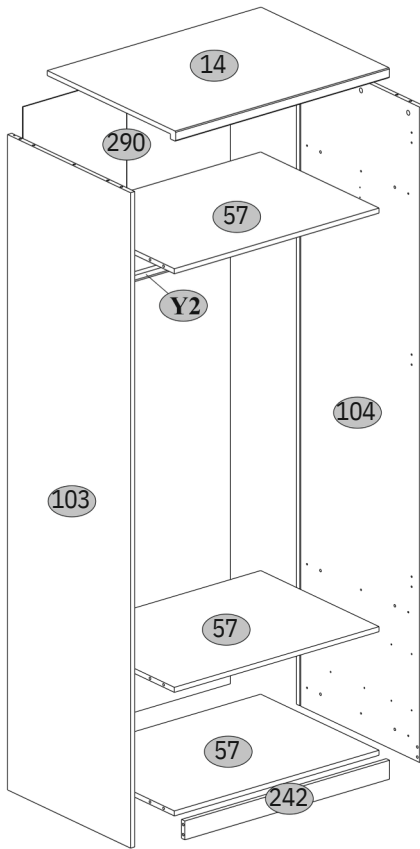

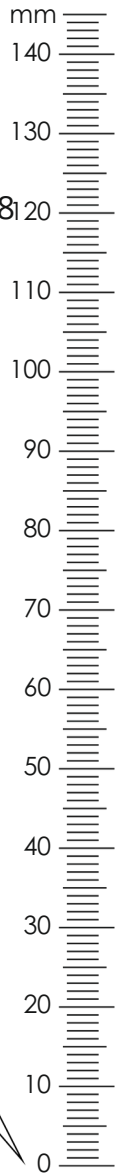



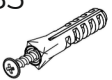
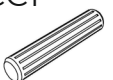
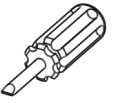
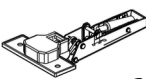

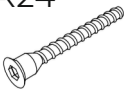

Stamp of Quality Department  
Pieczęć Działu Jakości

Nº	L, mm	B, mm	H, mm	Q	Nº pack
14	802	609	32	1	1/3
57	768	563	16	3	1/3
103	2084	583	16	1	2/3
104	2084	583	16	1	2/3
158	796	216	16	1	3/3
159	796	216	16	1	3/3
178	500	120	16	2	1/3
179	500	120	16	2	1/3
187	710	120	16	2	3/3
211	396	1592	16	1	3/3
242	768	60	16	1	1/3
290	2030	389	2,5	2	2/3
315	740	505	2,5	2	1/3
610	396	1592	16	1	3/3
Y2	761				3/3





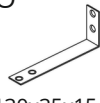

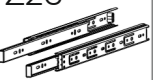
 A1 7x34 32	 A2 Ø15x12 32	 B5 10x50 1	 CC1 8x35 4208120
 D1-1 6	 E1-1 6	 H58 4	 I S4 1
 L2 500 2	 N1 4	 R3 3x20 28	 R23 6,3x13 12
 R24 7x50 8	 R27 5,0x13 28	 R32 4x27 8	 R102 3,5x16 22
 S1 18	 S5 Ø18 20	 U 130x35x15 1	 Y1 2
 Z26 500 2			

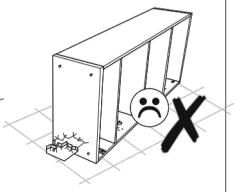
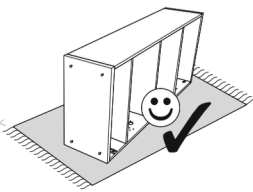
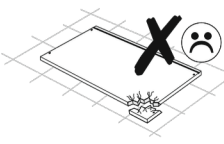
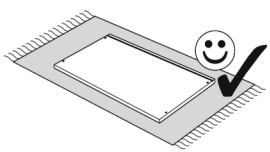
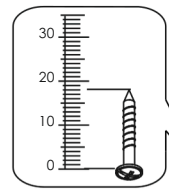
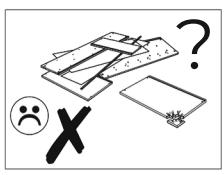
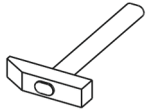
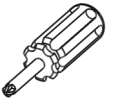
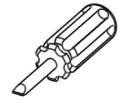

1

A1



7x34

18

CC1



8x35

404

D1-1



6

R23



6,3x13

12

R27



5,0x13

16

Z26

3

R102

3,5x16

4

Y1



Z26

2

500

2

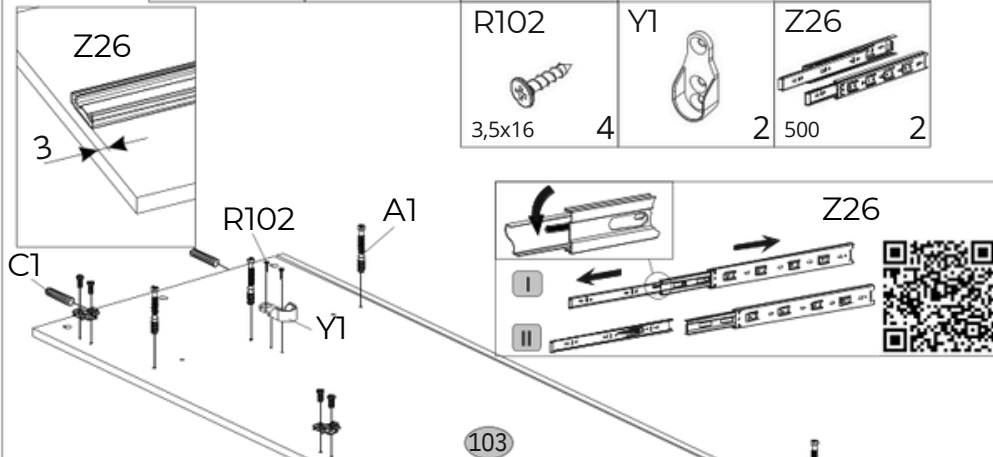

103

R102

Y1

103 104



C1



D1-1

R23

Z26

E1-1+D1-1

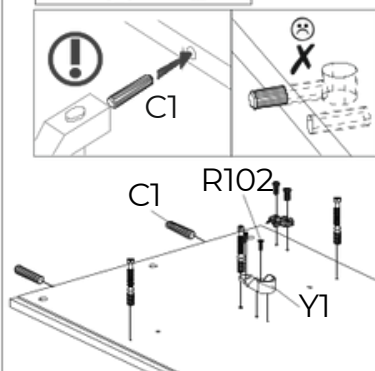
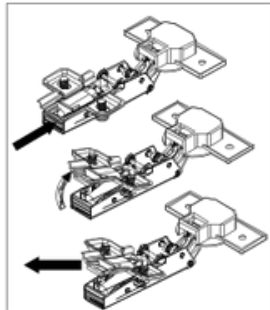

104

A1



R27

A1

Z26

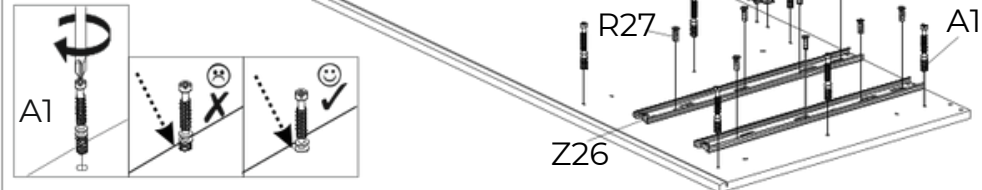

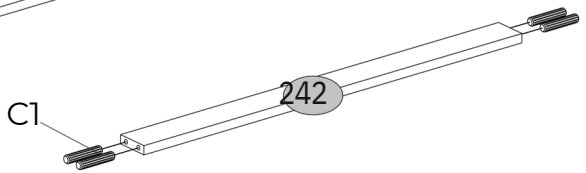
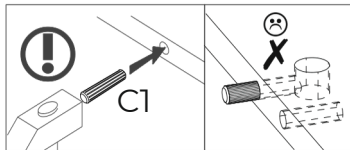
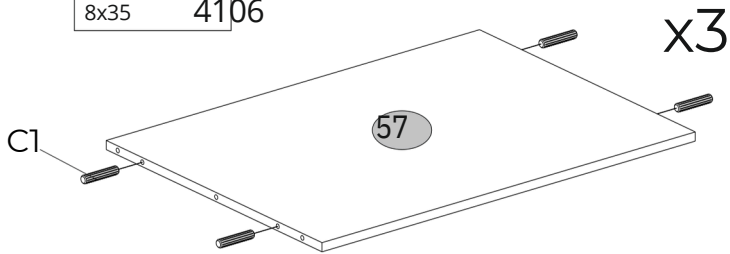
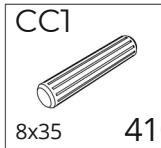

2

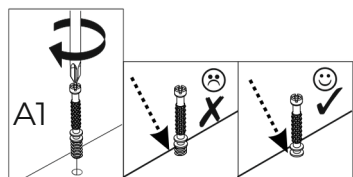
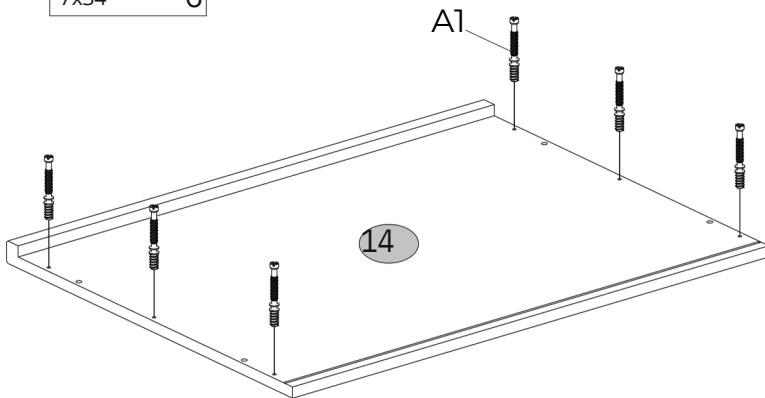
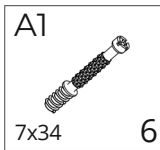

3



4

A2  Ø15x12 18	S5  Ø18 6
--	--

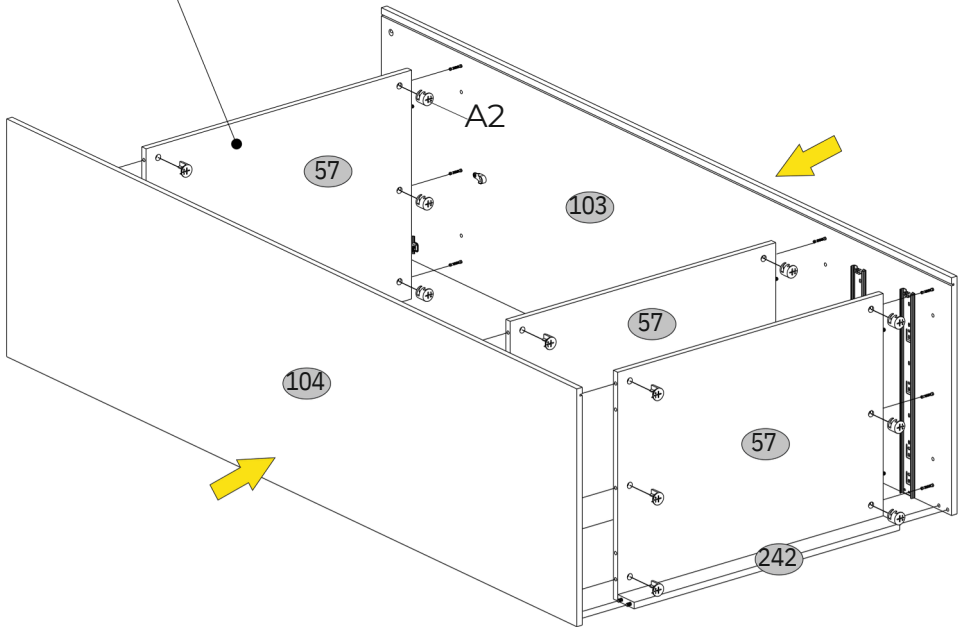
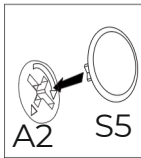
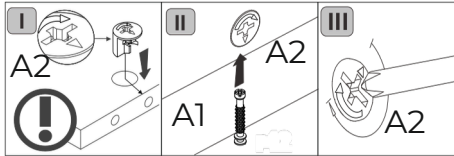

5

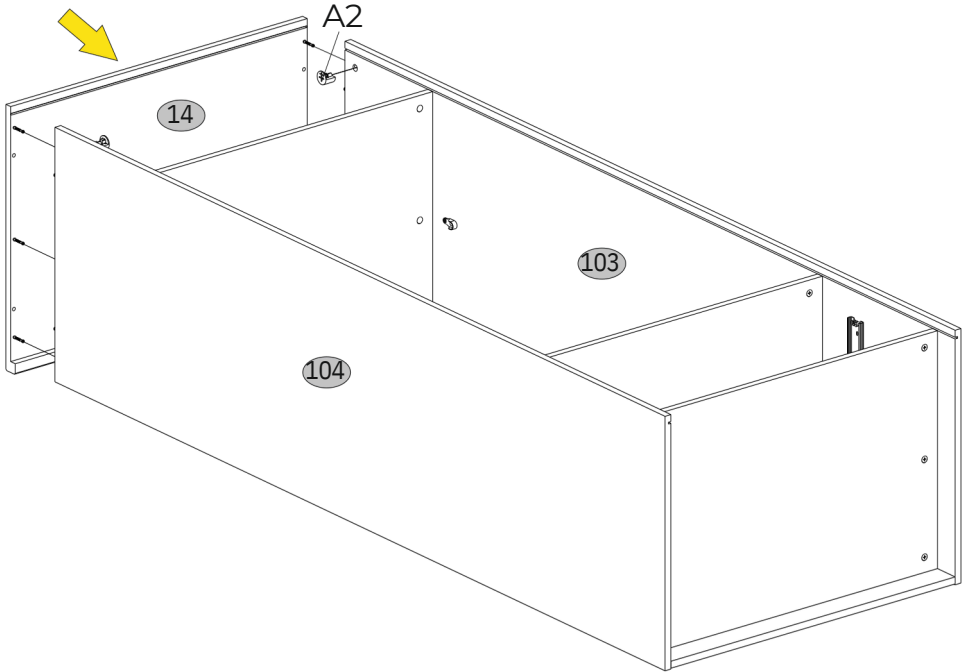
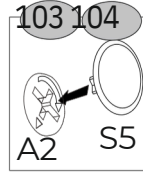
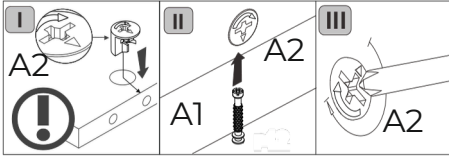
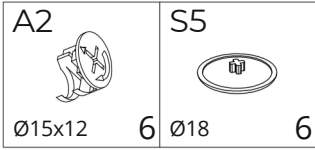



6

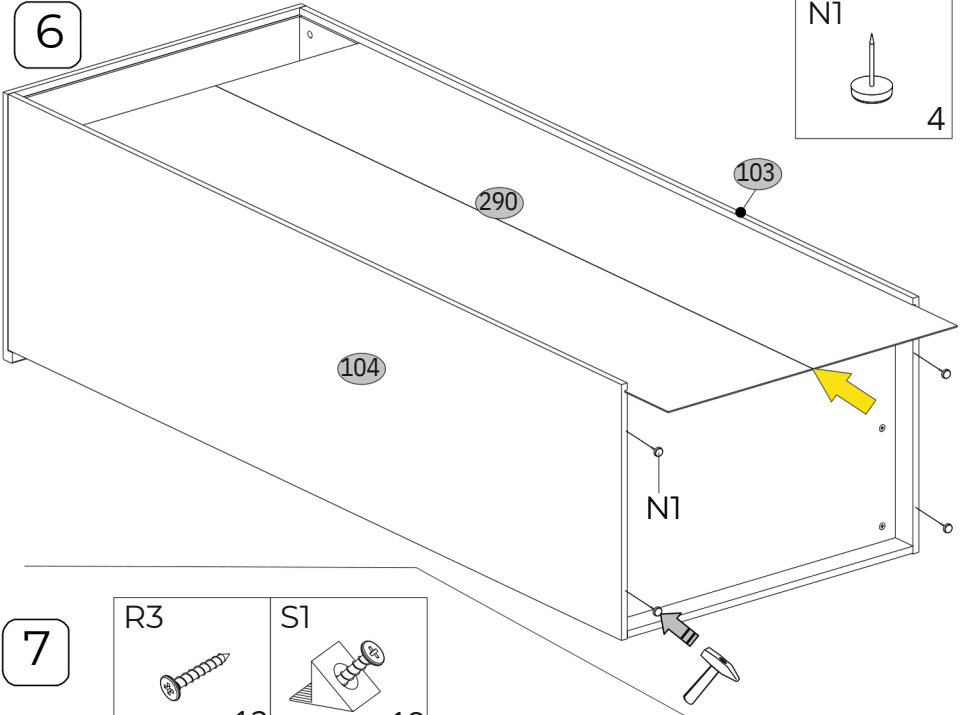
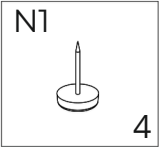

7

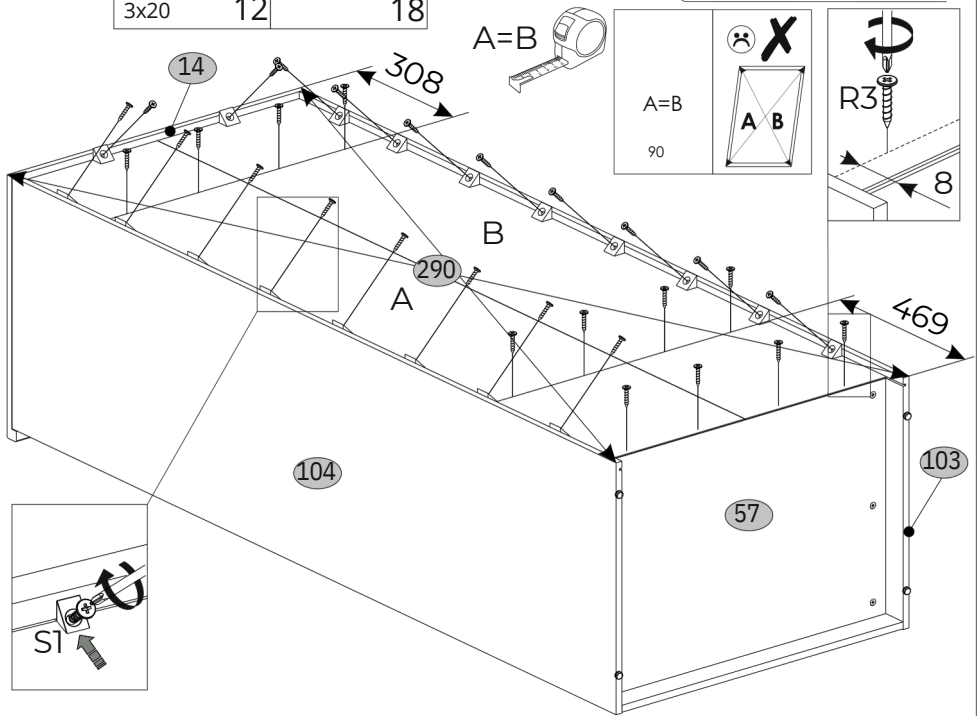
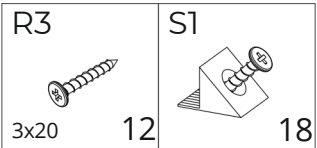

8

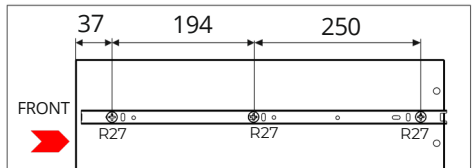
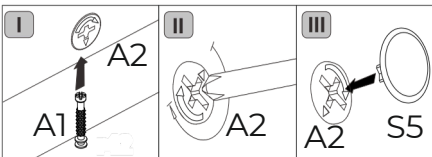
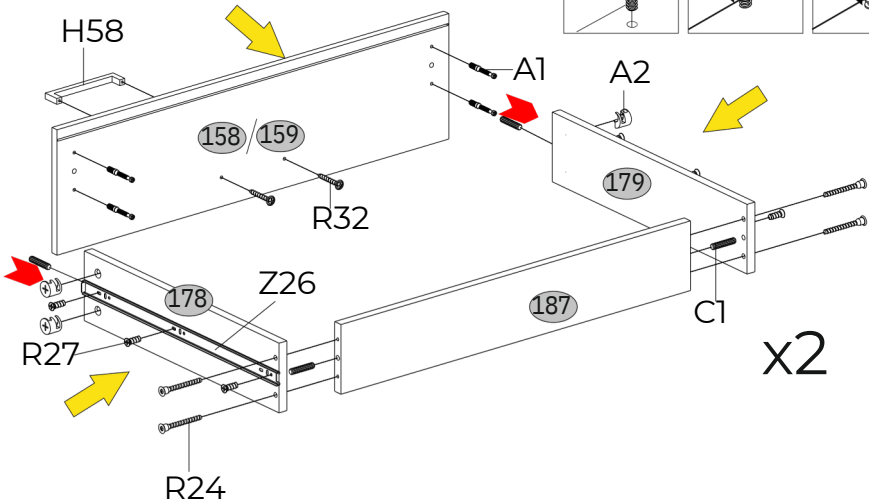
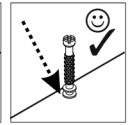
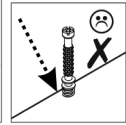
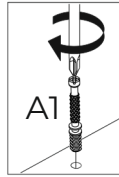
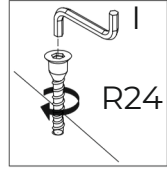
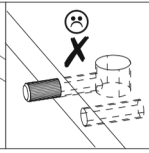
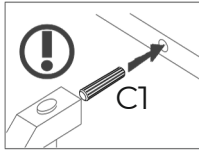
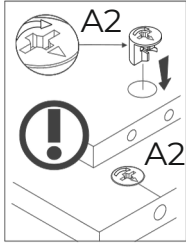

A1 7x34	A2 8 Ø15x12	CC1 8 8x35	H58 408	I 2 S4	1
R27 5,0x13	R24 12 7x50	R32 8 4x27	S5 4 Ø18	Z26 8 500	2

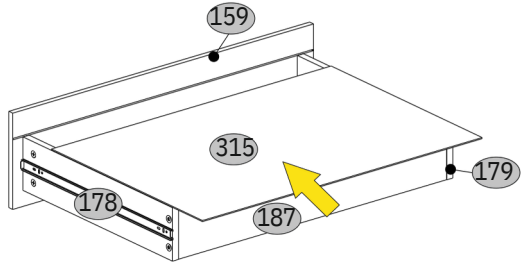
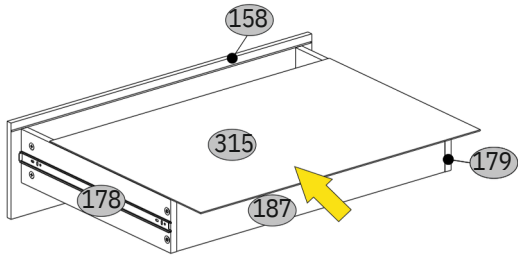

9



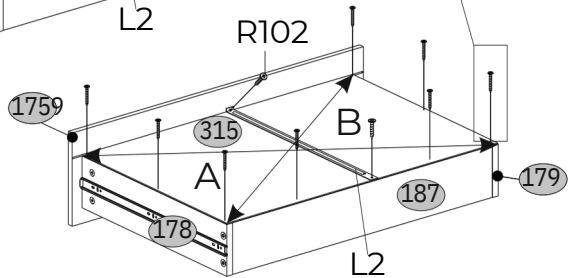
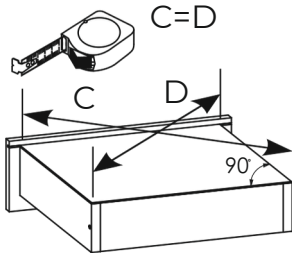
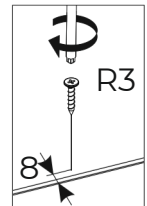
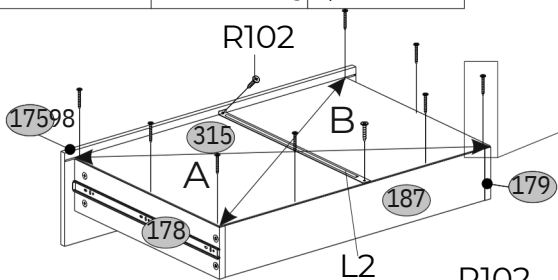

10

L2	R3	R102
		
500 2	3x20 16	3,5x16 4



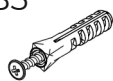

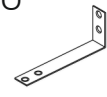

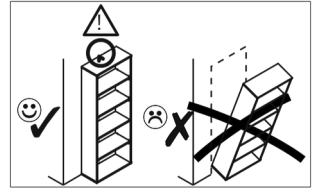
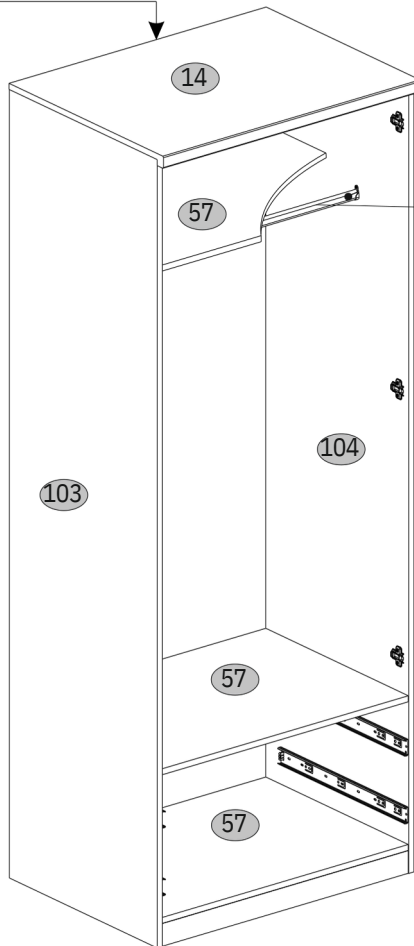
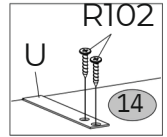
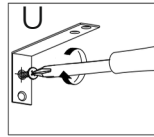
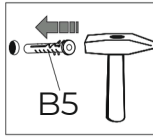
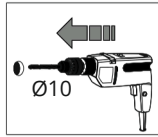
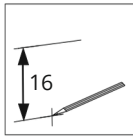
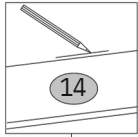
11

B5  10x50 1	R102  3,5x16 2	U  130x35x15 1
--	---	---



Y2 57 14  max. 10 kg

12

E1-1	H58	R32	R102
			
6	2	4x27	4 3,5x16 12

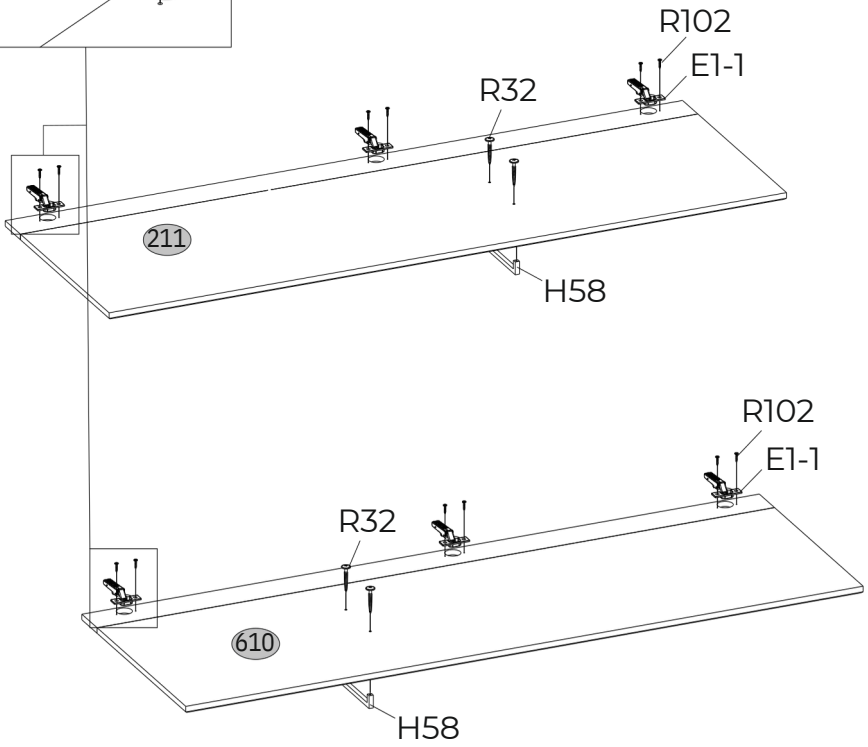
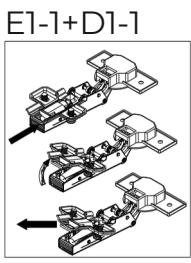
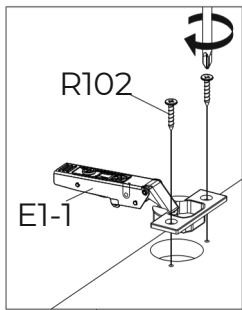

13

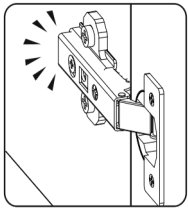
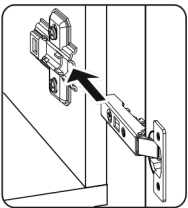

158 159 max. 5 kg

