

# Instrukcja montażu mebli

## «DOORSET»

Szafka na buty 1d1s



---





















Production date  
Data produkcji

---

Stamp of Quality Department  
Pieczęć Działu Jakości

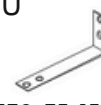

105 76 147 53 106  
16  
292  
58  
246  
190 177  
212 176 316  
163

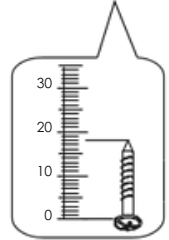
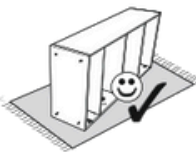
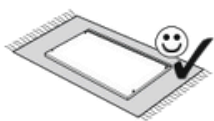
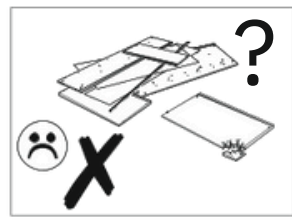
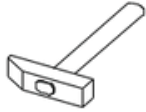
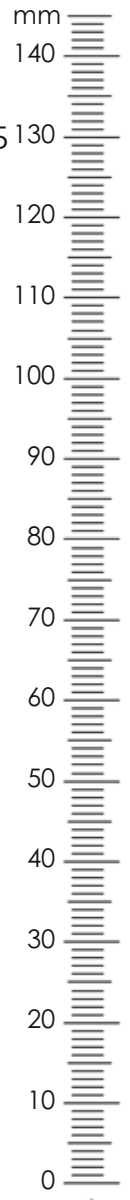

A1  7x34 18	A2  Ø15x12 18	B5  10x50 1	CC1  8x35 4205
D1-1  2	E1-1  2	H58  2	I  S4 1
N1  5	P5  4	R3  3x20 16	R23  6,3x13 4
R24  7x50 6	R27  5,0x13 10	R32  4x27 4	R102  3,5x16 6
S1  8	S3  2	S5  Ø18 10	U  130x35x15 1
Z10  300 1			



1

A1  7x34	CC1  6 8x35	N1  4103	1
---	--	---	---

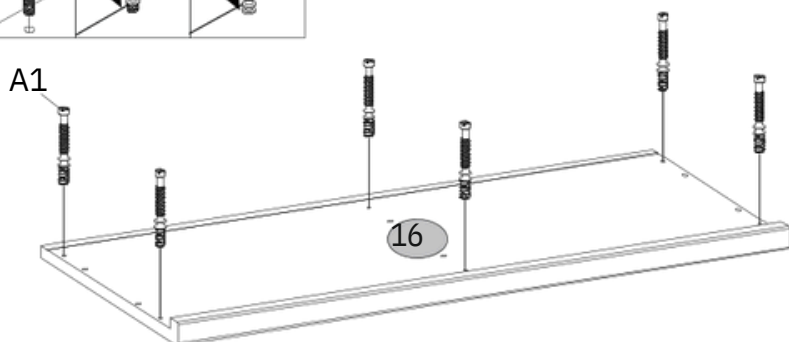
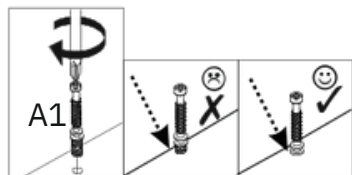
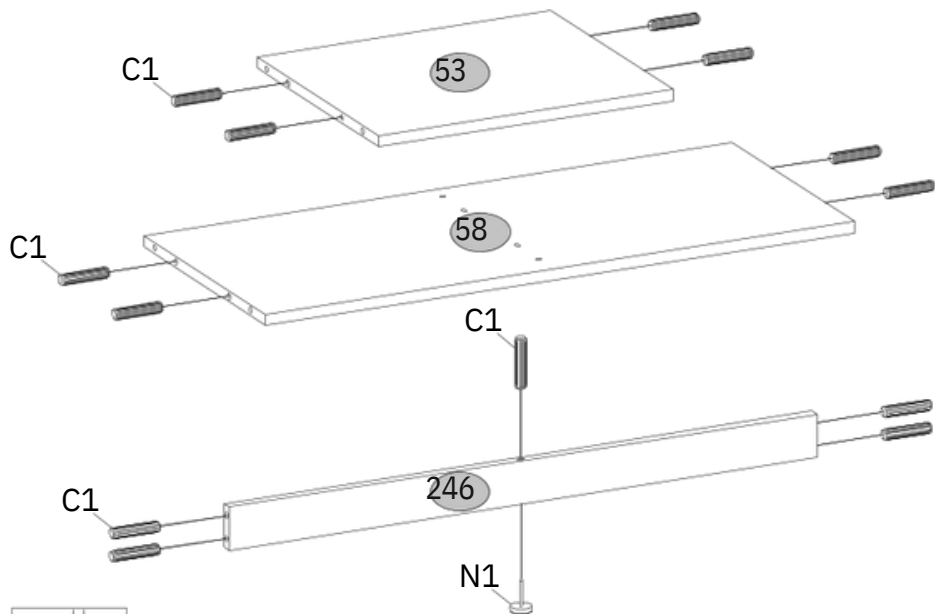
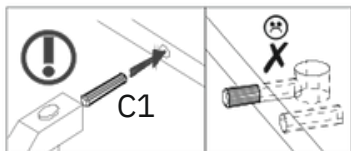

2

A1 7x34 8	CC1 8x35 408	D1-1 2	N1 4	P5 4
R23 6,3x13 4	R27 5,0x13 6	Z10 300 1		

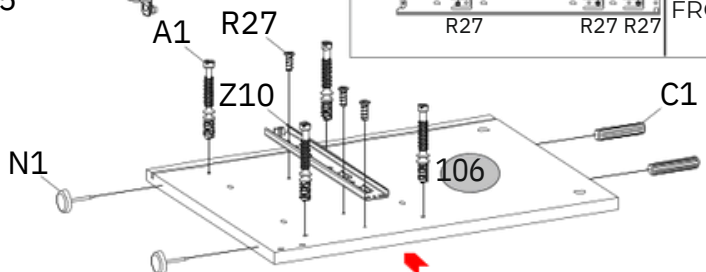
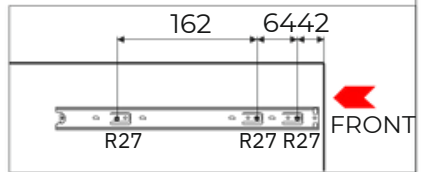
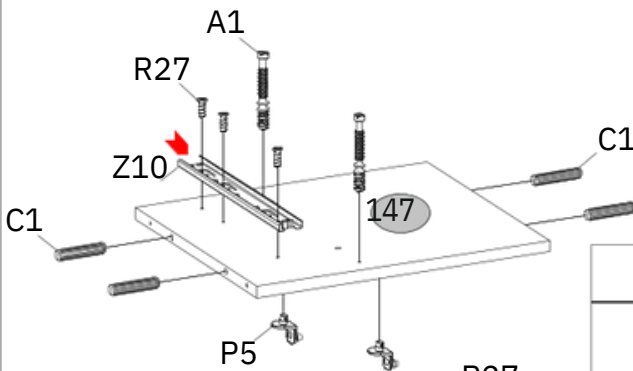
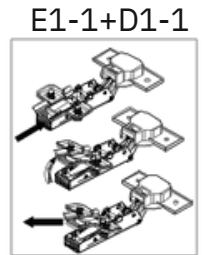
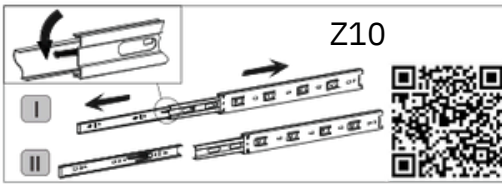
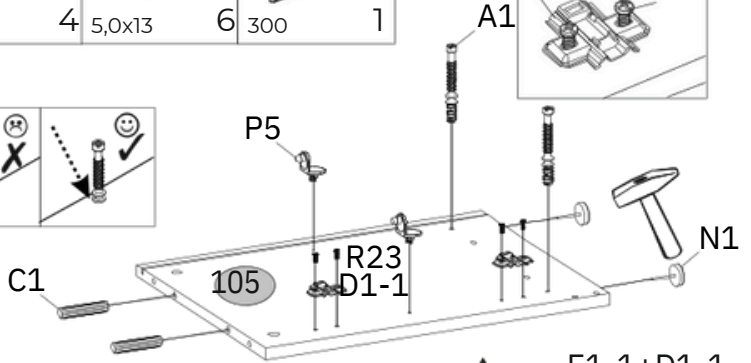
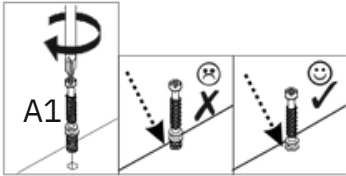

3

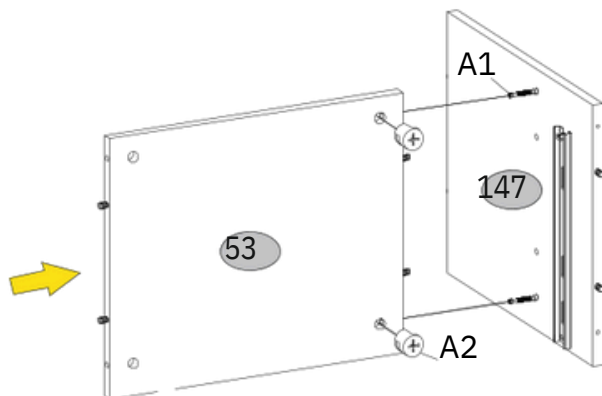
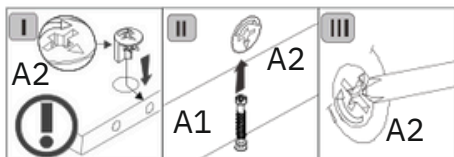
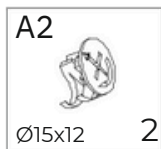

4

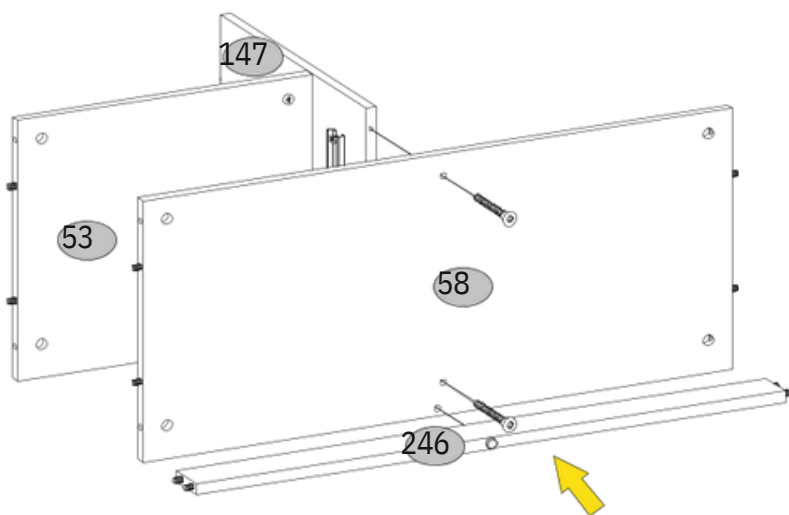
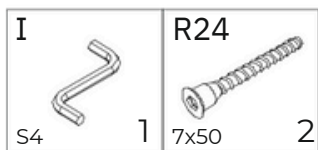

5

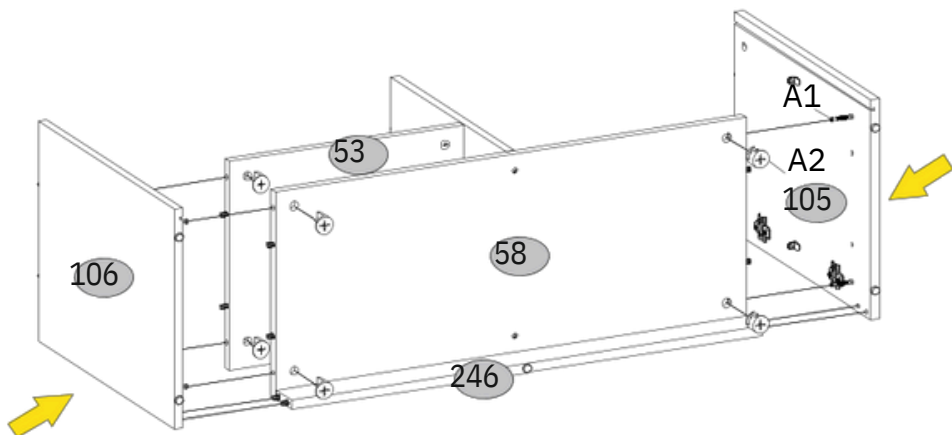
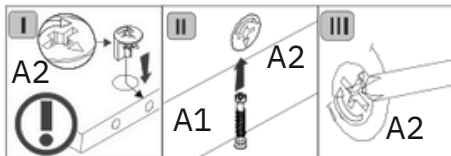
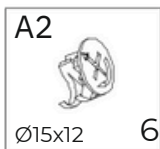

6

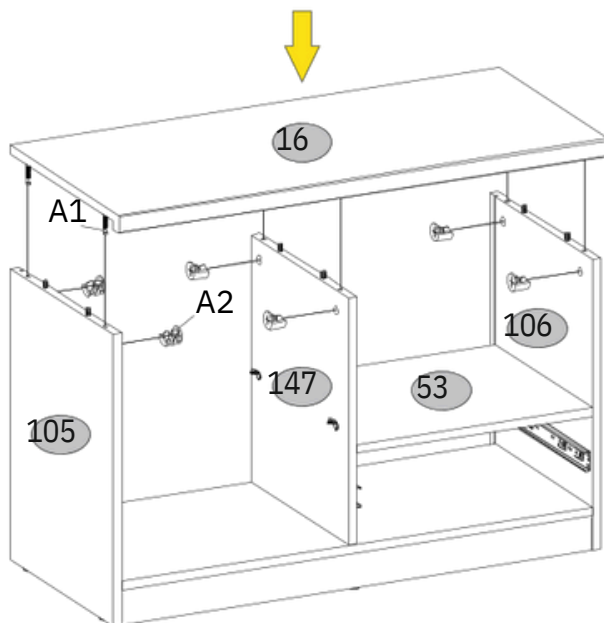
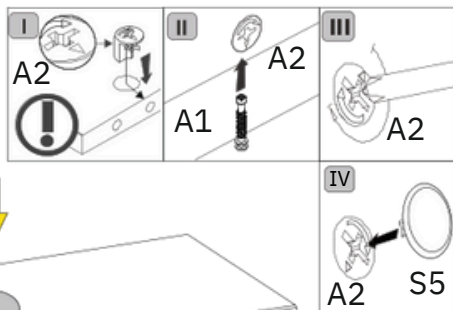
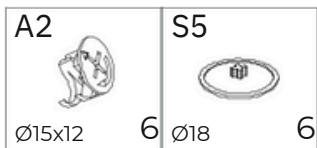

7

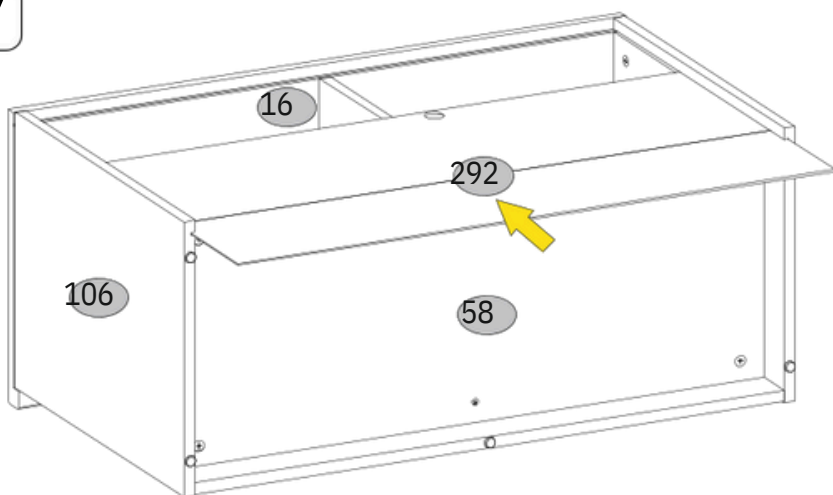

8

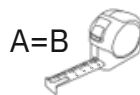
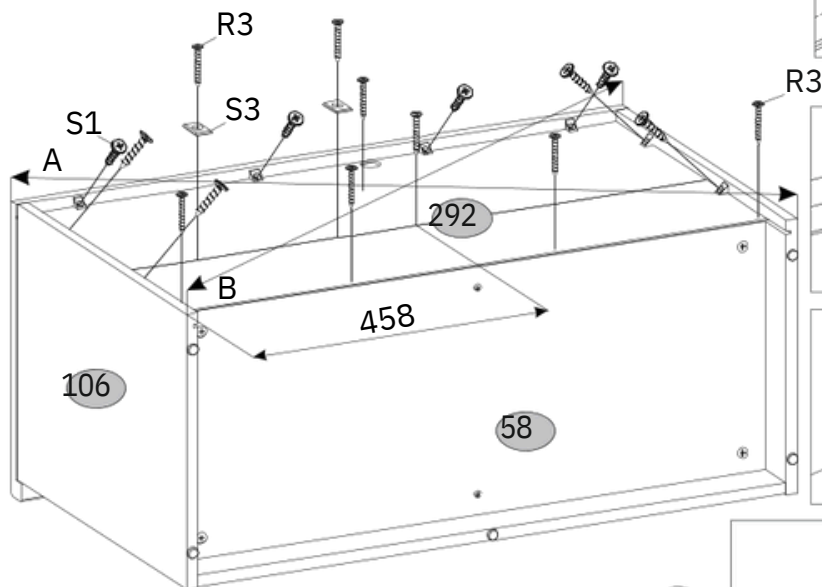
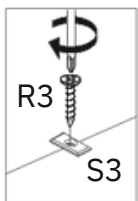
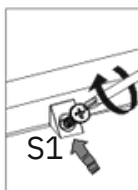
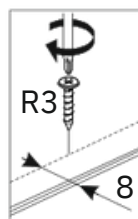

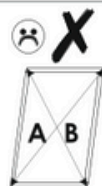

A=B

90







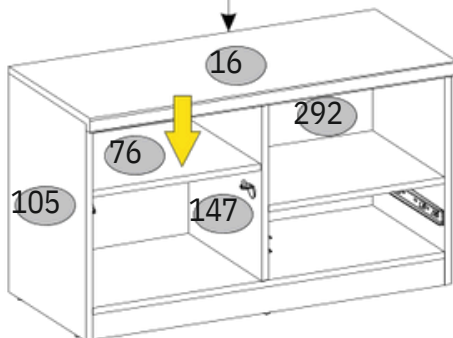
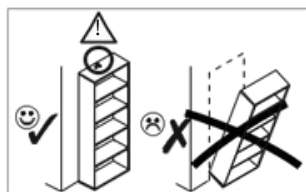
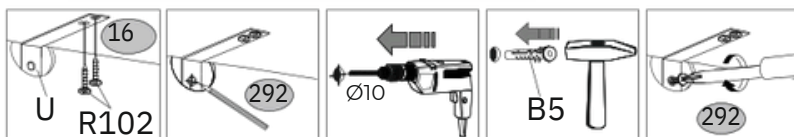
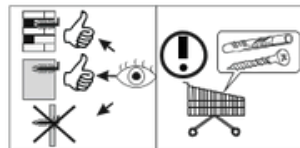

9

<b>B5</b>  10x50	<b>R102</b>  3,5x16	<b>U</b>  130x35x15
1	2	1





10

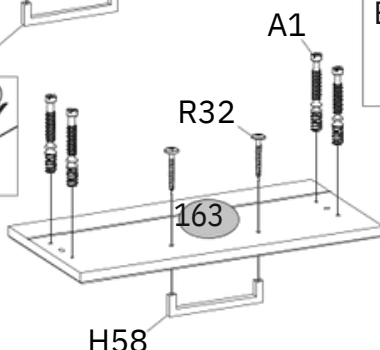
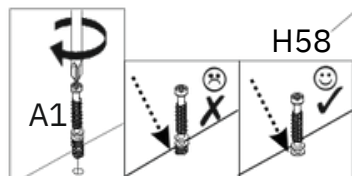
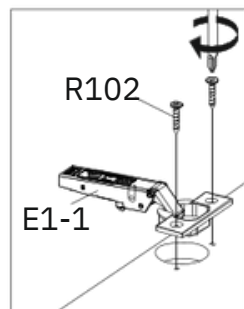
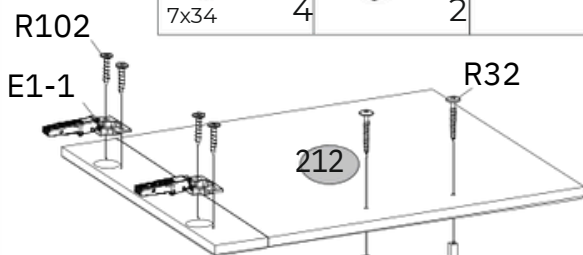



<b>A1</b>  7x34	<b>E1-1</b>  2	<b>H58</b>  2	<b>R102</b>  3,5x16	<b>R32</b>  4x27
4	2	2	4	4

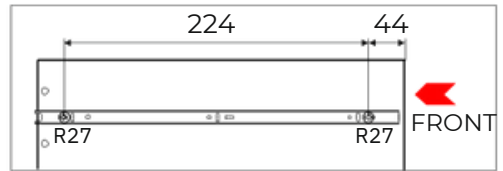
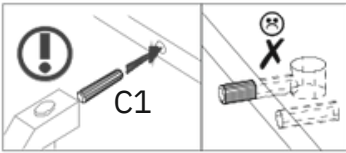
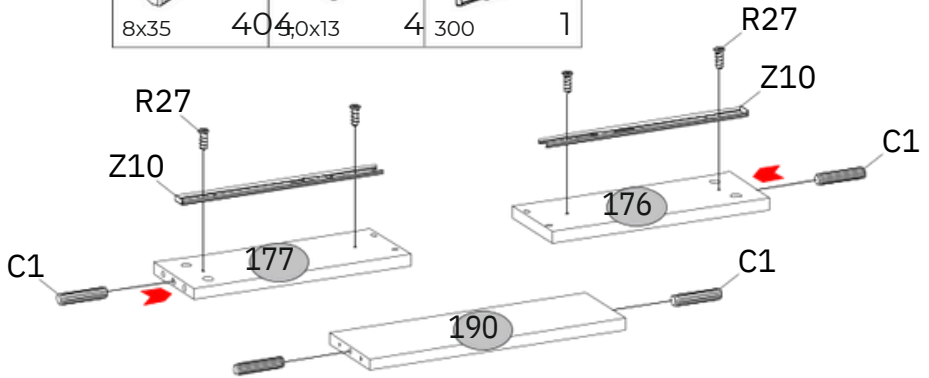

**11**

CC1  8x35	R27  4 04,0x13	Z10  4 300	1
--	---	---	---

**12**

A2  Ø15x12	I  4 S4	R24  1 7x50	S5  4 Ø18	4
---	--	--	--	---

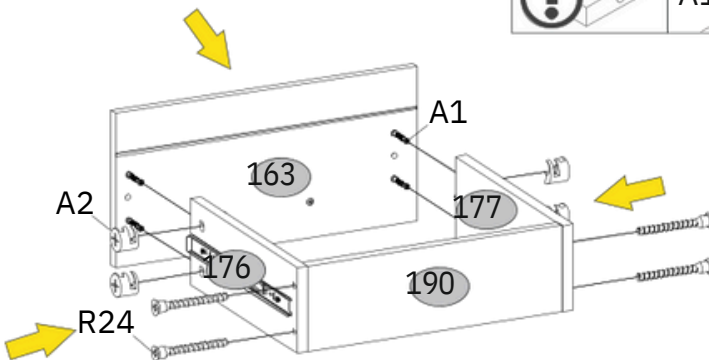
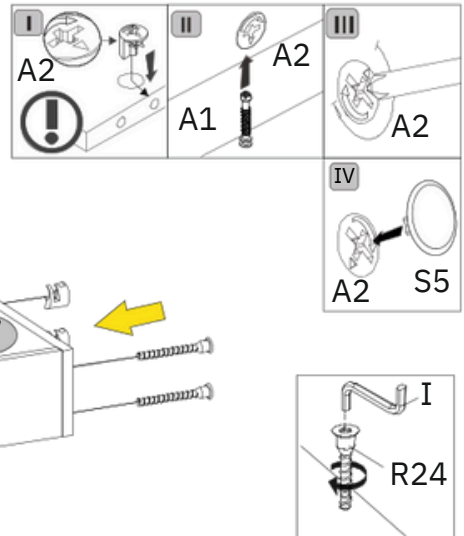

13

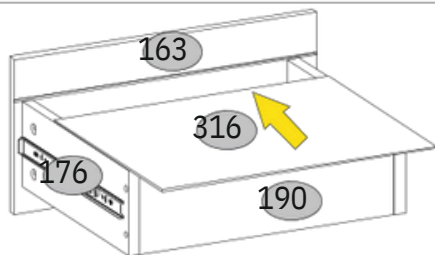

14

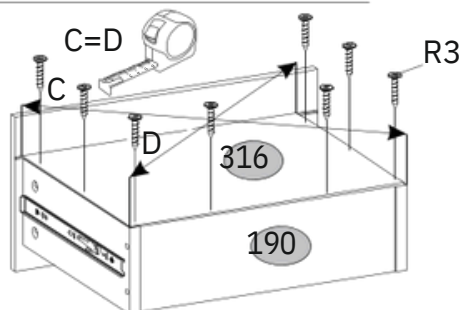
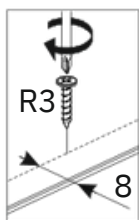
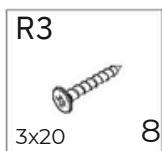

15

