

Instrukcja montażu mebli

«DOORSET»

Szafka na buty 2k

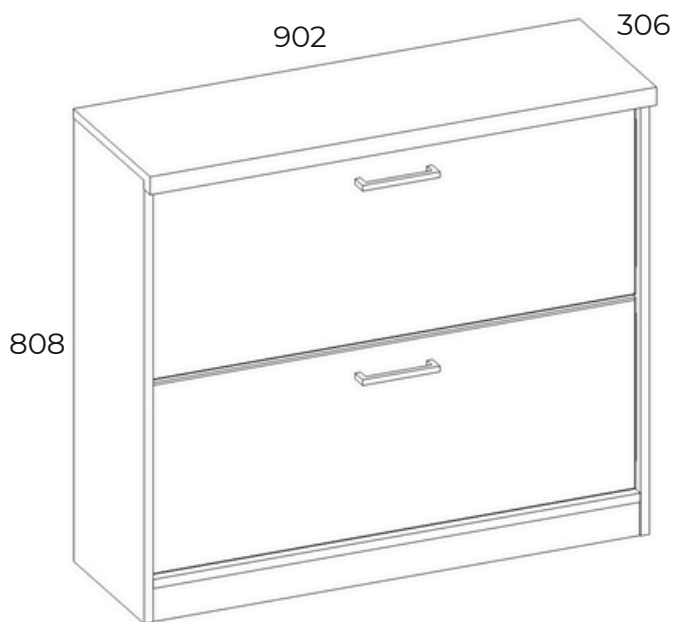





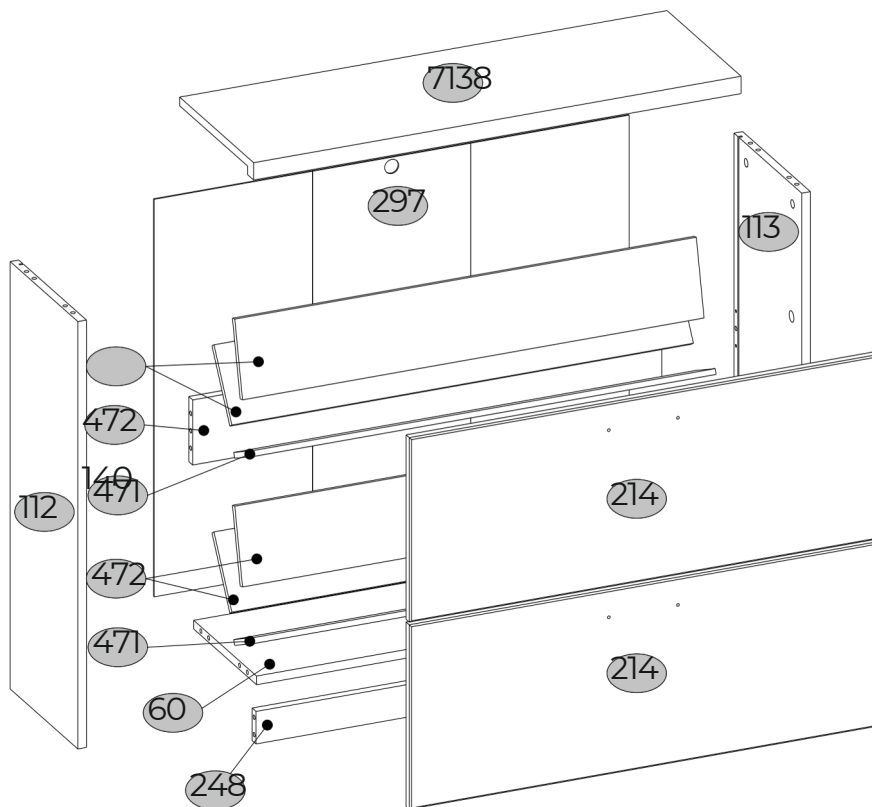







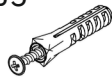
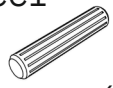



Production date
Data produkcji

Stamp of Quality Department
Pieczęć Działu Jakości





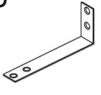

| № | L, mm | B, mm | H, mm | Q | № pack |
|-----|-------|-------|-------|---|--------|
| 18 | 902 | 306 | 32 | 1 | 2/2 |
| 60 | 868 | 260 | 16 | 1 | 2/2 |
| 112 | 788 | 280 | 16 | 1 | 2/2 |
| 113 | 788 | 280 | 16 | 1 | 2/2 |
| 140 | 868 | 120 | 16 | 1 | 2/2 |
| 214 | 864 | 340 | 16 | 2 | 1/2 |
| 248 | 868 | 60 | 16 | 1 | 2/2 |
| 297 | 733 | 879 | 2,5 | 1 | 2/2 |
| 471 | 854 | 90 | 10 | 2 | 1/2 |
| 472 | 854 | 140 | 10 | 4 | 1/2 |

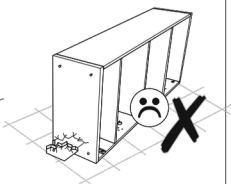
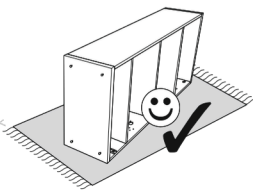
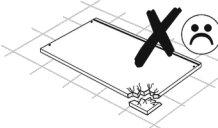
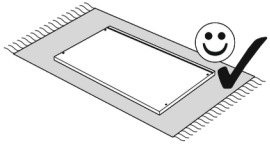
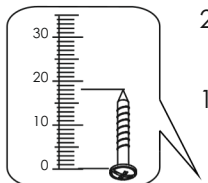
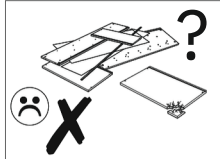
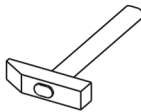
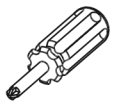
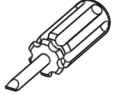
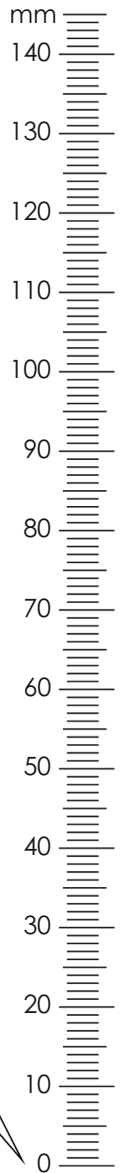

| | | | |
|---|---|---|--|
| A1  7x34 12 | A2  Ø15x12 12 | B5  10x50 1 | CC1  8x35 4104 |
| J1  2 | J2  4 | J3  4 | J4  4 |
| H58  2 | N1  4 | R1  3x13 12 | R3  3x20 6 |
| R19  6,0x13 4 | R32  4x27 4 | R102  3,5x16 17 | S51  Ø18 48 |
| | S5  Ø18 4 | U  130x35x15 1 | |

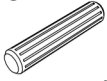

1

| | | | | |
|---|--|--|--|--|
| A1  7x34 | CC1  8 8x35 | J2  404 | J4  4 | N1  4 |
|---|--|--|--|--|

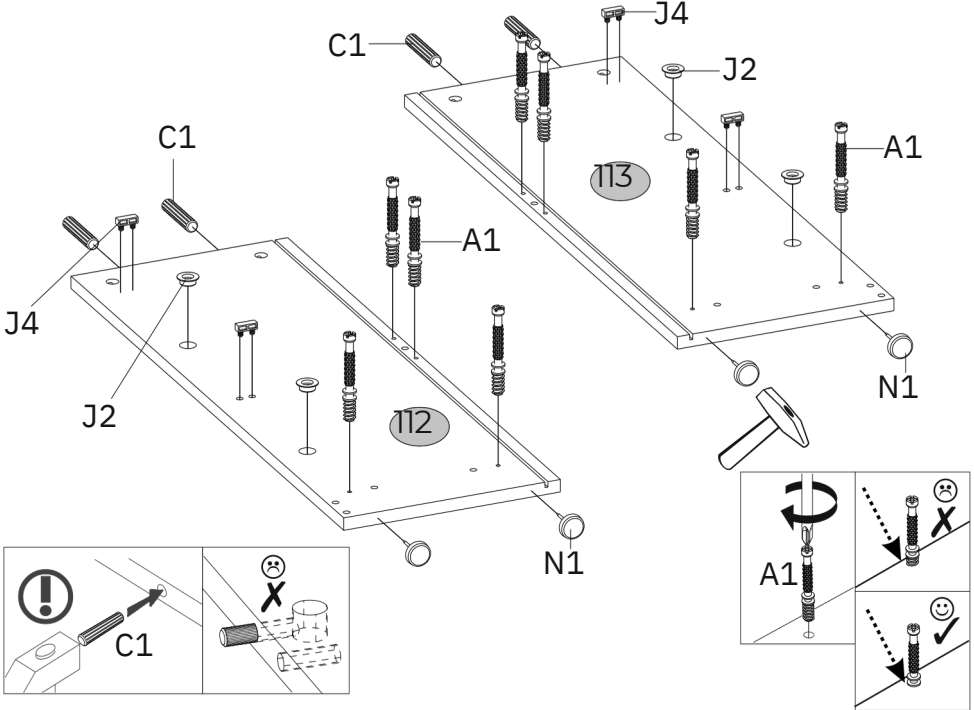

2

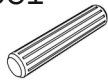
| | |
|--|-----|
| CC1  8x35 | 410 |
|--|-----|

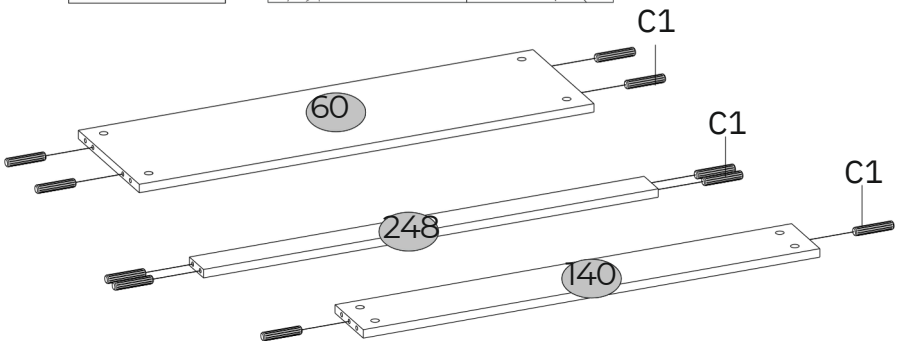
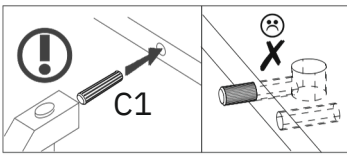

3

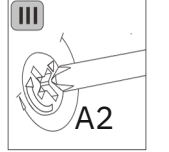
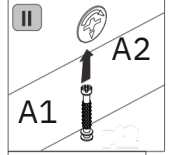
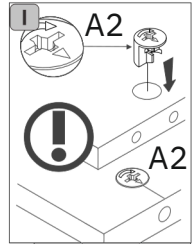
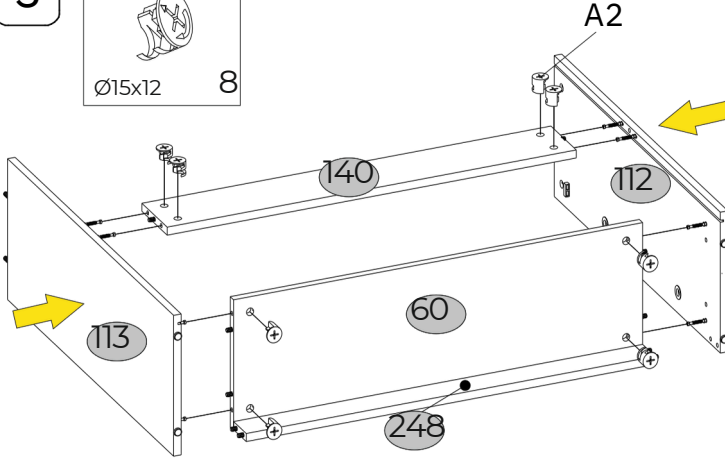
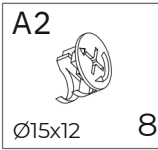

4

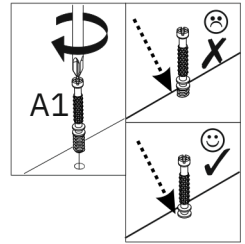
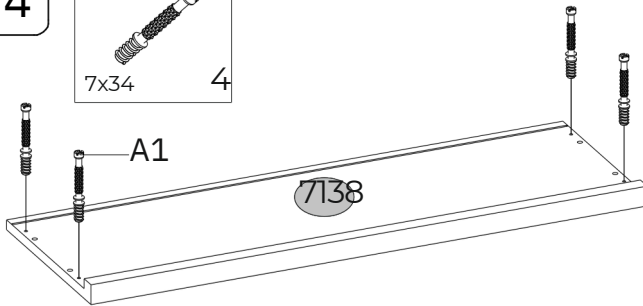
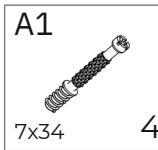

5

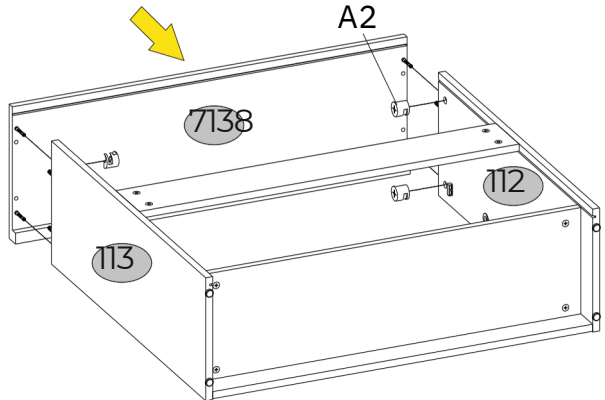
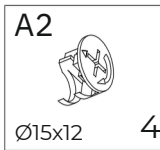

6

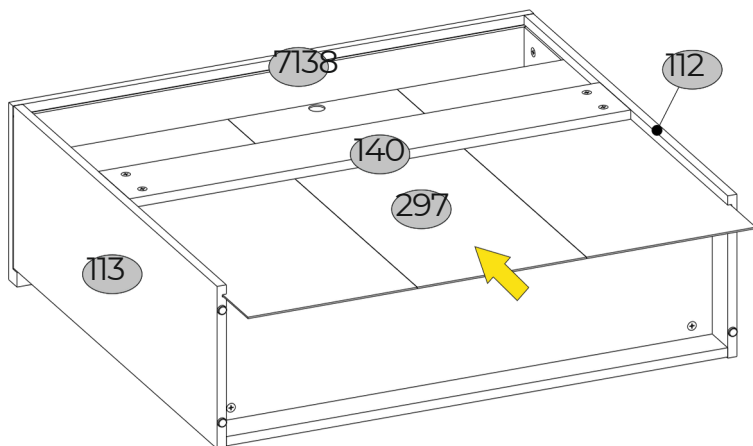

7

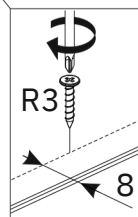
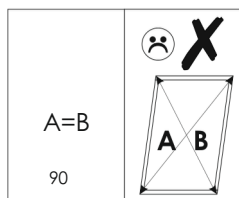
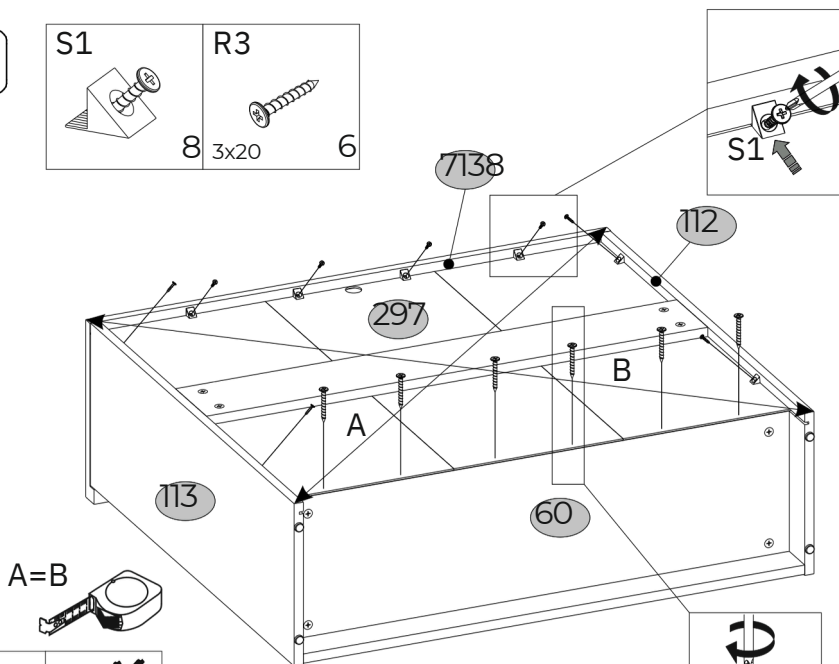
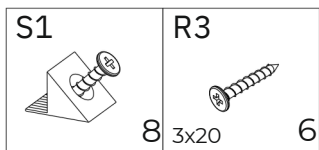

8
x2

| | | | | |
|---------|----------|-----------------|------------------|----------------------|
| J1 2 | H58 2 | R1 3x13 2 | R32 4x27 4 | R102 3,5x16 12 |
|---------|----------|-----------------|------------------|----------------------|

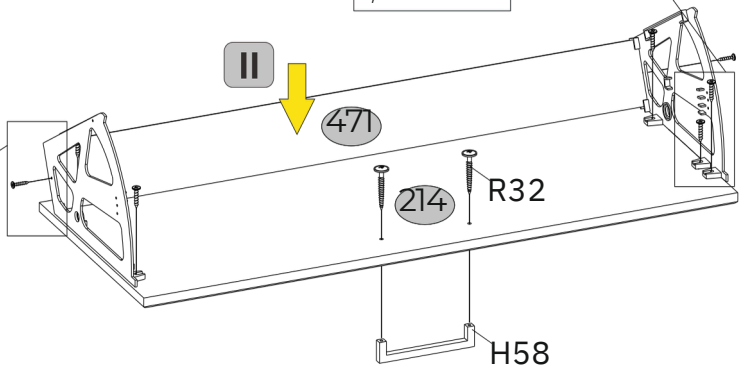
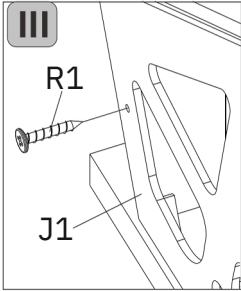
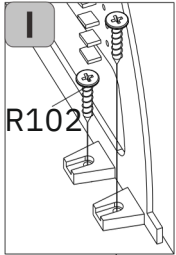



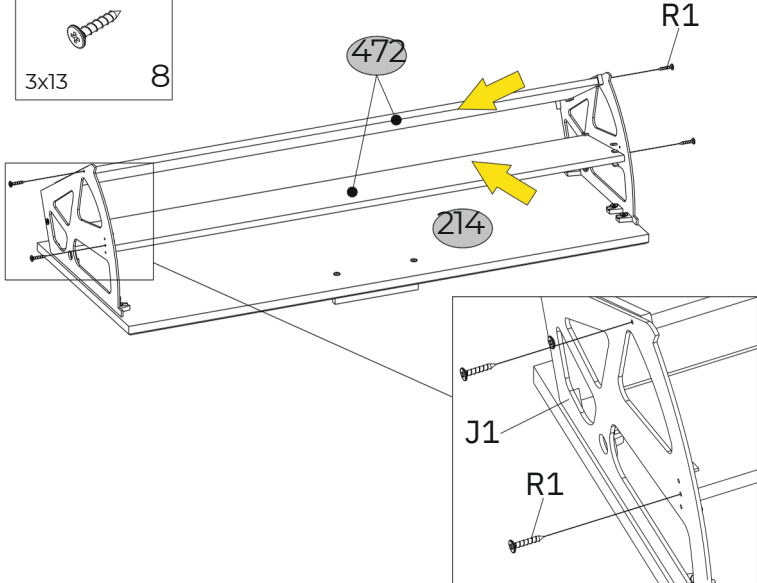

9
x2

| |
|-----------------|
| R1 3x13 8 |
|-----------------|

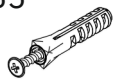

10

| | | | |
|---|--|---|--|
| B5  10x50 | R102  3,5x16 | S5  5 Ø18 | U  4 130x35x15 |
|---|--|---|--|

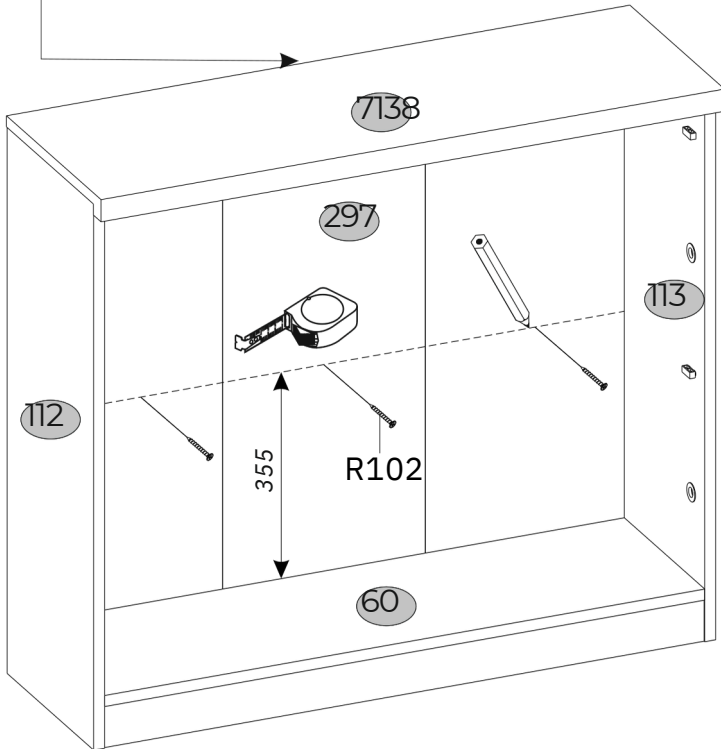
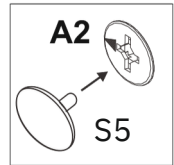
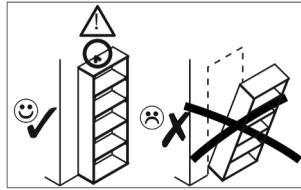
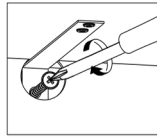
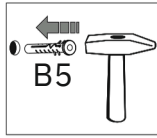
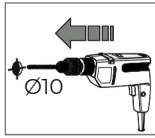
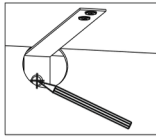
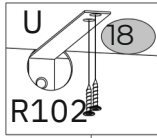

11

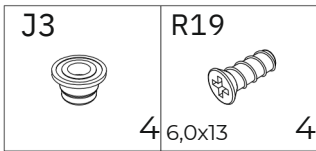

214  max. 3 kg

18  max. 10 kg

