

# Instrukcja montażu mebli

## «DOORSET»

Szafka na buty 2d

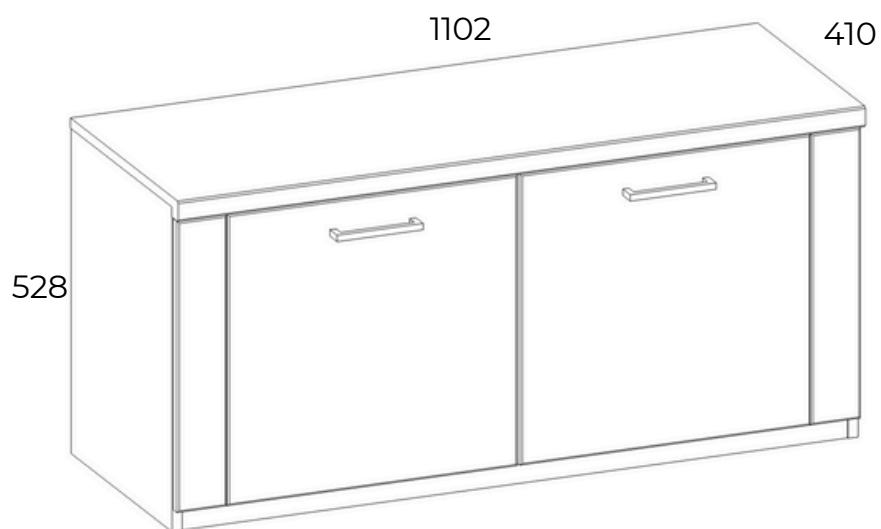

---

Production date  
Data produkcji







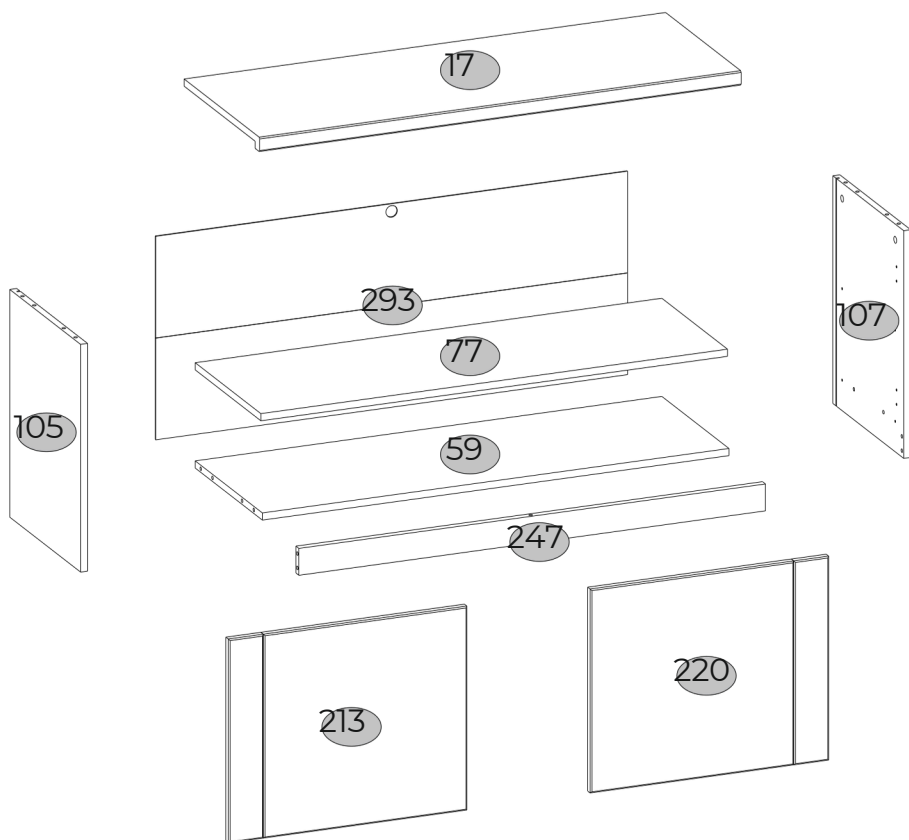



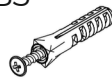
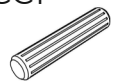
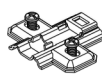
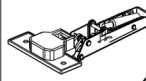

---

Stamp of Quality Department  
Pieczęć Działu Jakości

Nº	L, mm	B, mm	H, mm	Q	Nº pack
17	1102	410	32	1	1/1
59	1068	364	16	1	1/1
77	1068	356	22	1	1/1
105	508	384	16	1	1/1
107	508	384	16	1	1/1
213	546	455	16	1	1/1
220	546	455	16	1	1/1
247	1068	60	16	1	1/1
293	1080	454	2,5	1	1/1



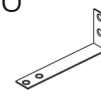

A1  7x34 8	A2  Ø15x12 8	B5  10x50 8	CC1  8x35 1	4103
D1-1  4	E1-1  4	H58  2	N1  5	
P5  4	R3  3x20 5	R23  6,3x13 8	R32  4x27 4	
R102  3,5x16 10	S1  8	S5  Ø18 4	U  130x35x15 1	

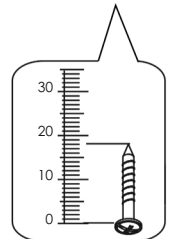
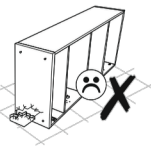
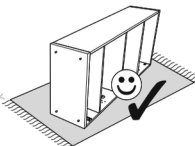
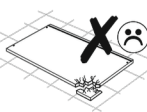
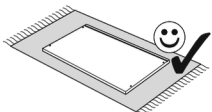
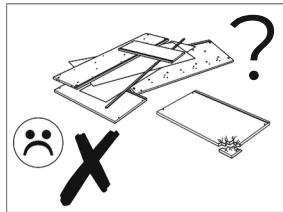
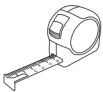
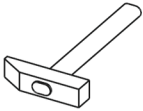
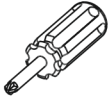
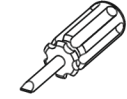
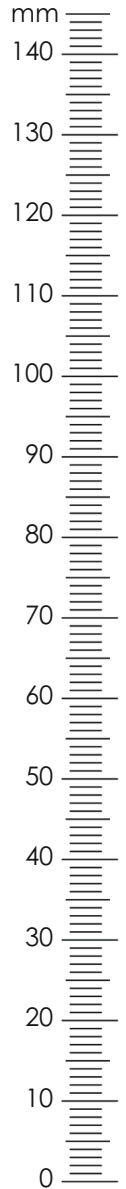

7

A1 7x34 8	CC1 8x35 4	P5 103 4	N1 5
-----------------	------------------	----------------	---------

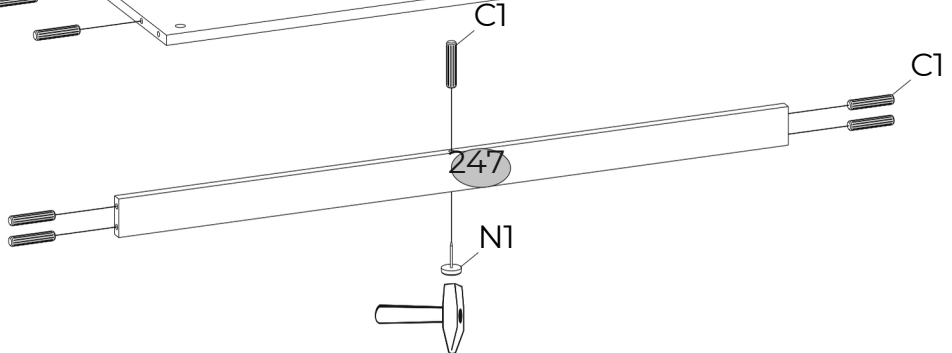
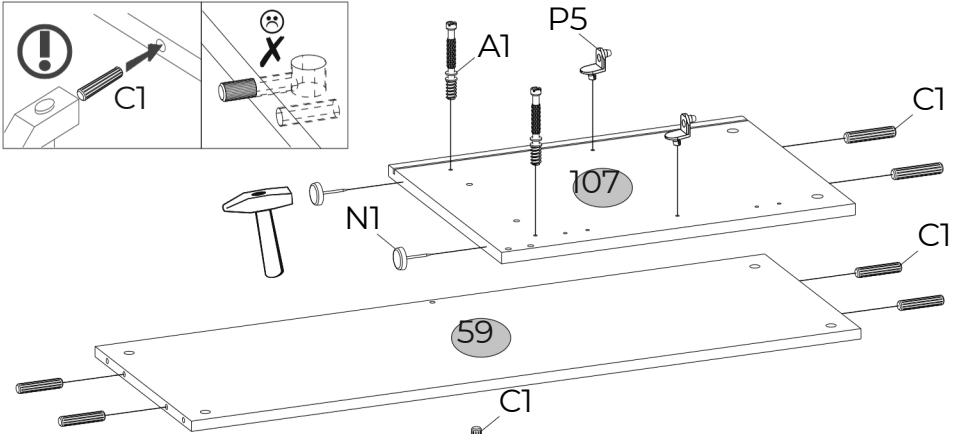
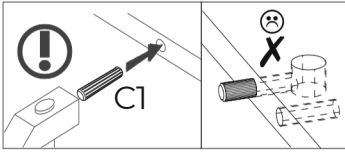
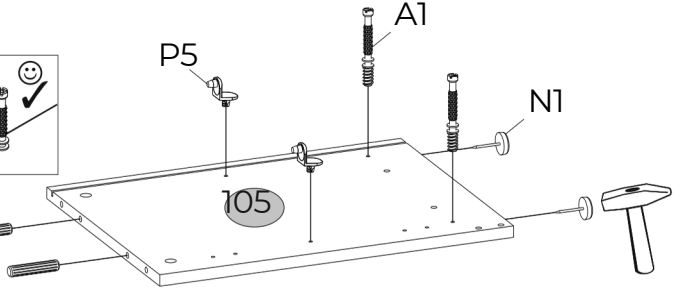
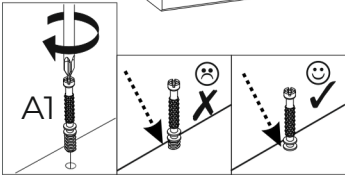
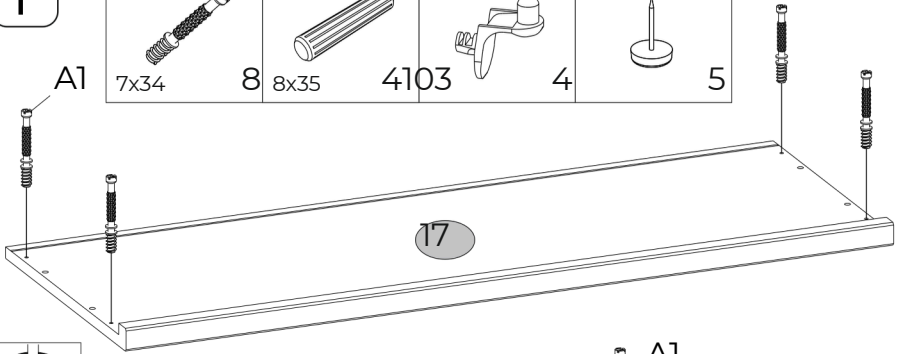

2

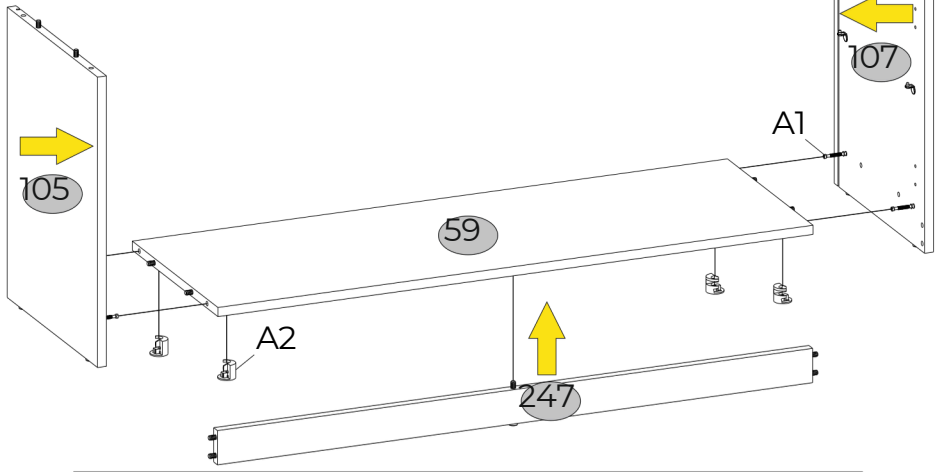
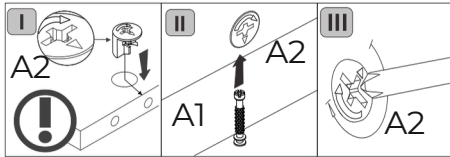
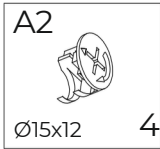

3

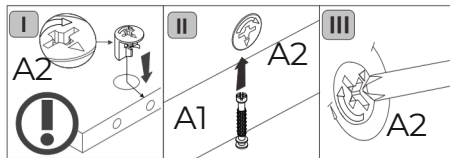
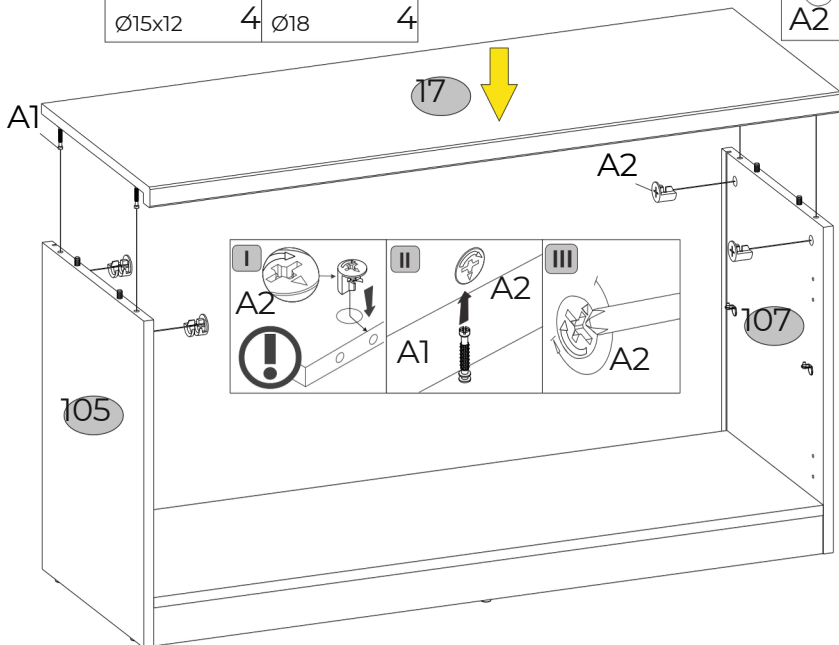
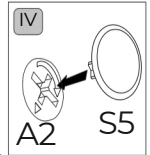
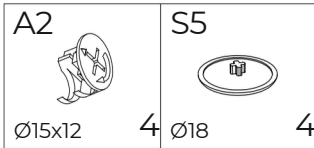

4

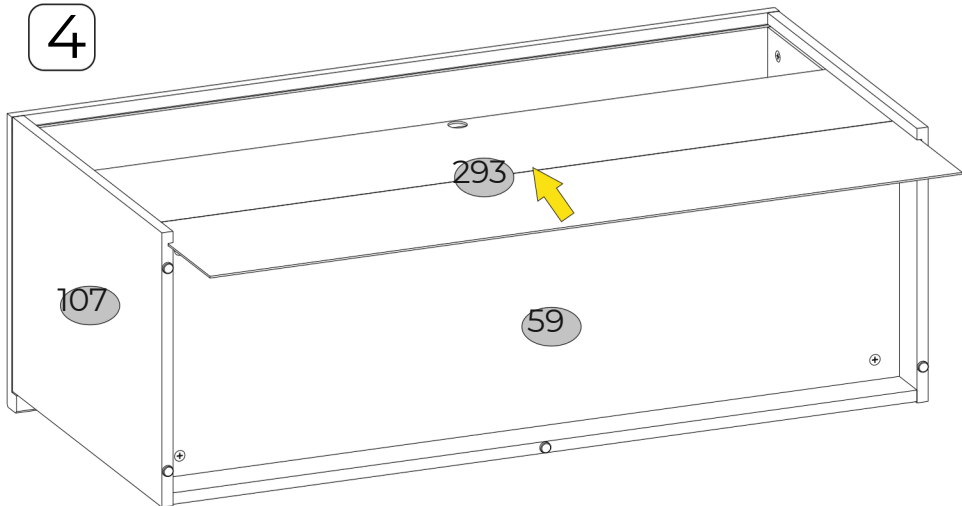

5

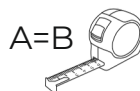
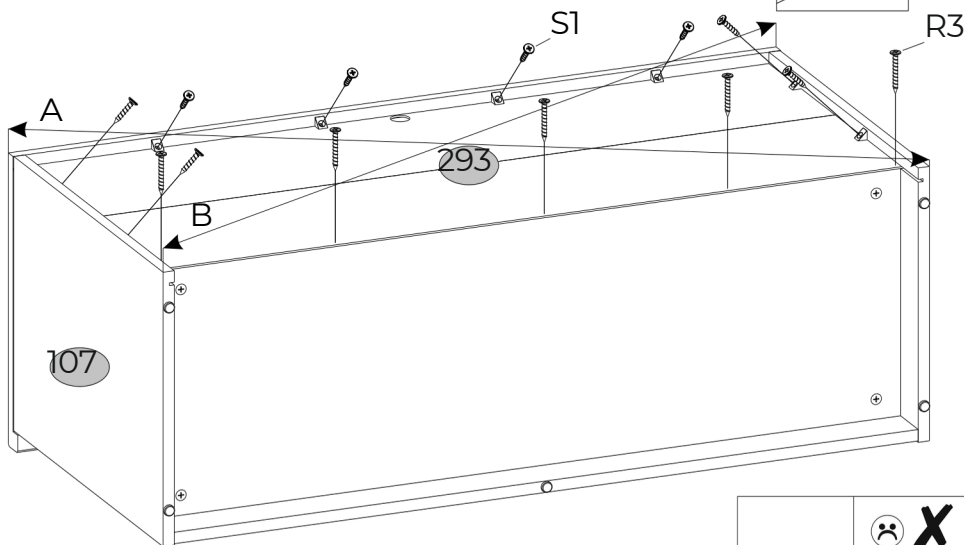
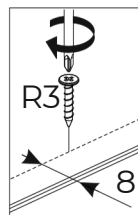
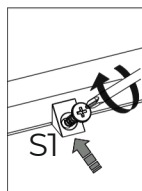
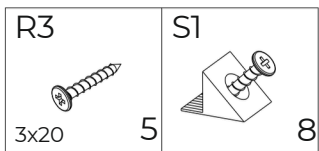

A=B

90

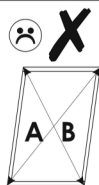

6

B5

10x50

1

R102

3,5x16

1

U

130x35x15

2

1

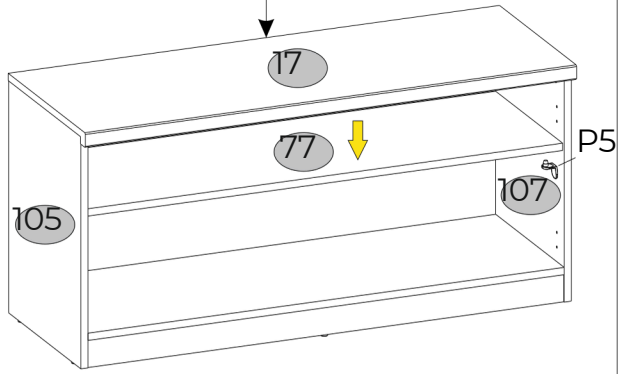
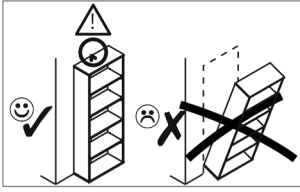
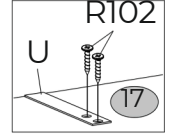
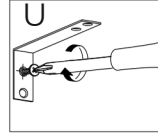
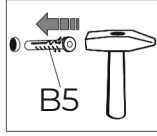
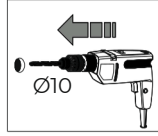
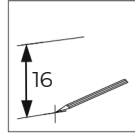
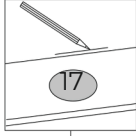
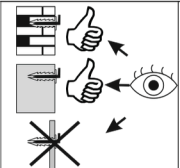

7

D1-1

4

R23

6,3x13





8

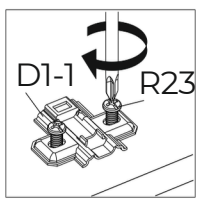
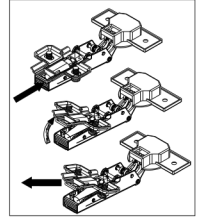

E1-1+D1-1



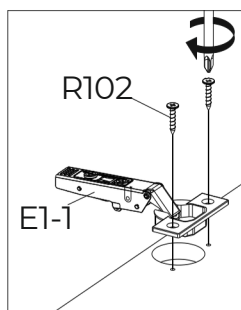
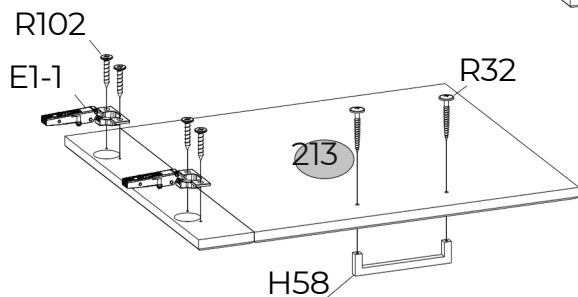
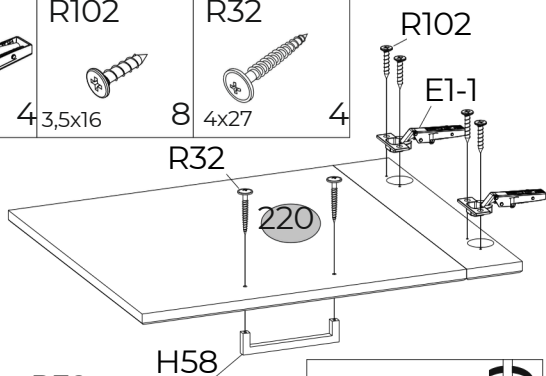

8

H58  2	E1-1  4	R102  4 3,5x16	R32  8 4x27
-----------------------------------------------------------------------------------------------	------------------------------------------------------------------------------------------------	-------------------------------------------------------------------------------------------------------	----------------------------------------------------------------------------------------------------

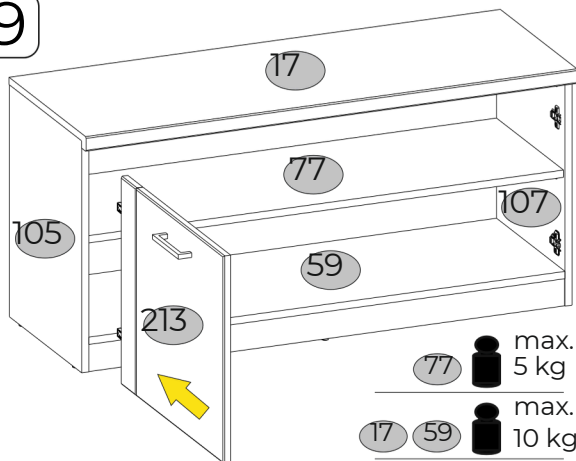

9



 max. 5 kg  
 max. 10 kg

