

# CESAR

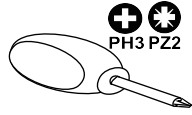

30min

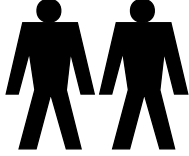

PH3 PZ2

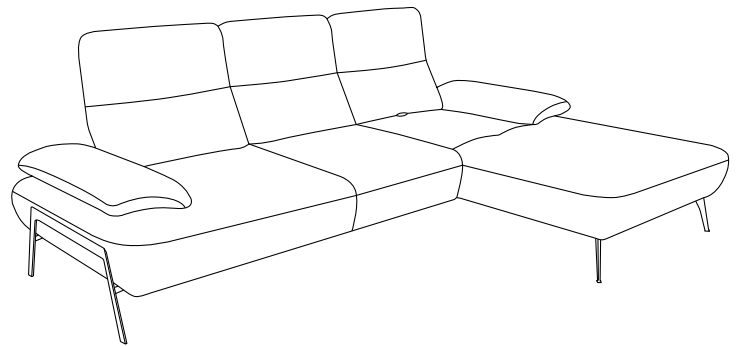
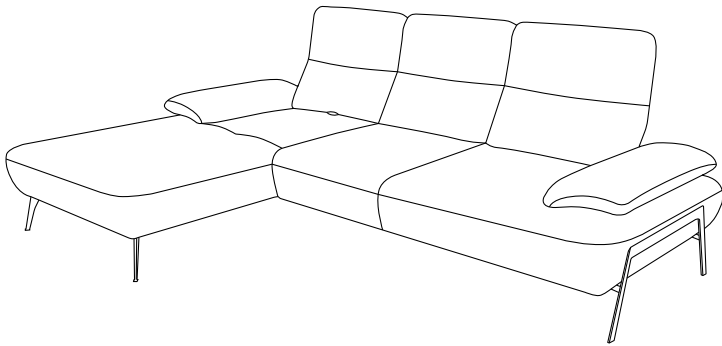
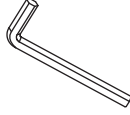

I

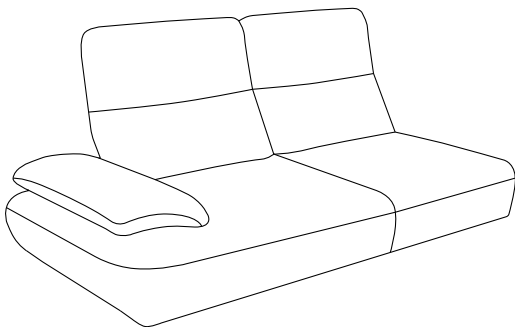

II

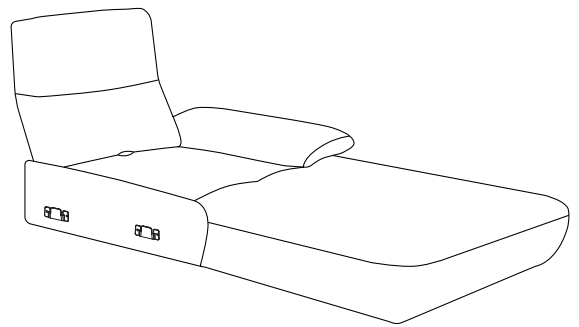

**Ax2**



H=195 mm

**Bx3**

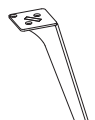

H=195 mm

**Cx1**

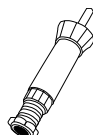

H=130-230 mm

**Dx3**

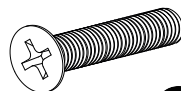

6x30



**Ex6**

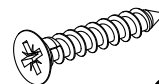

5x30



**Fx4**

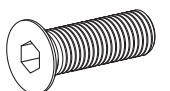

8x30

1

**Ax1**

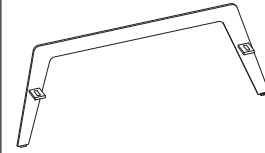

H=195 mm

**Fx2**

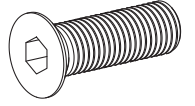

8x30

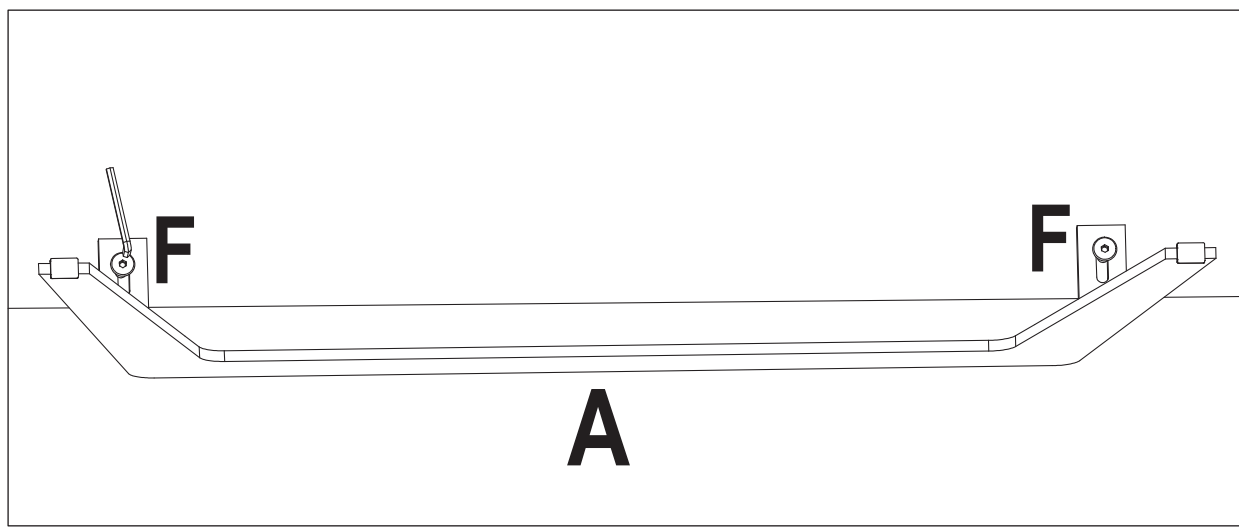

2

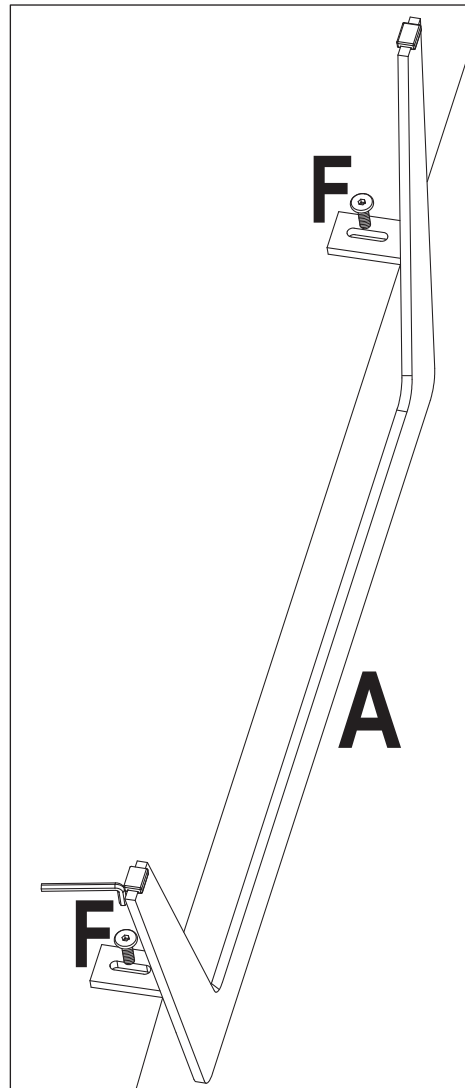
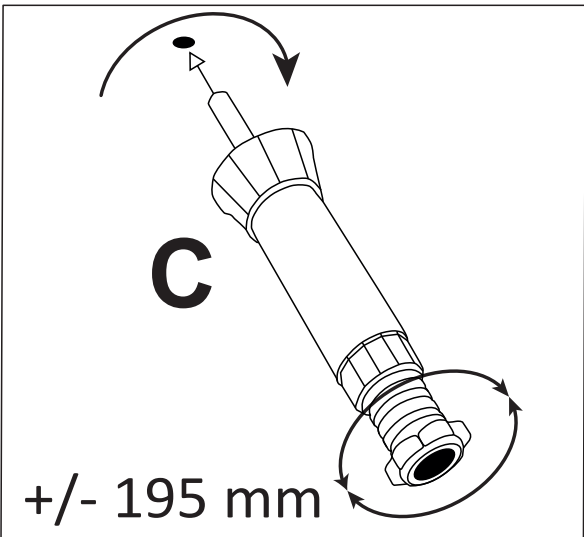
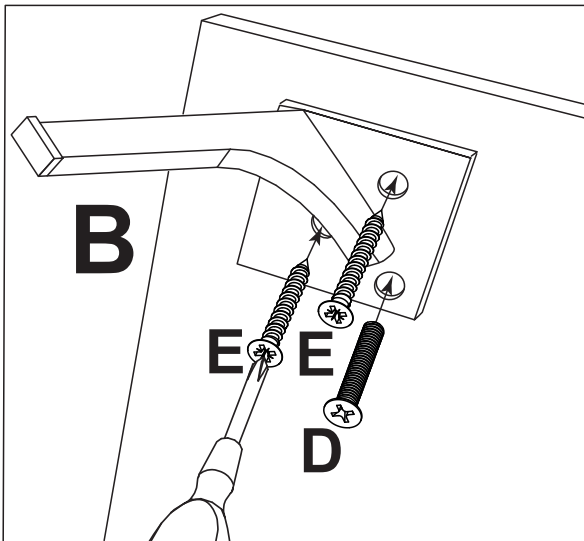
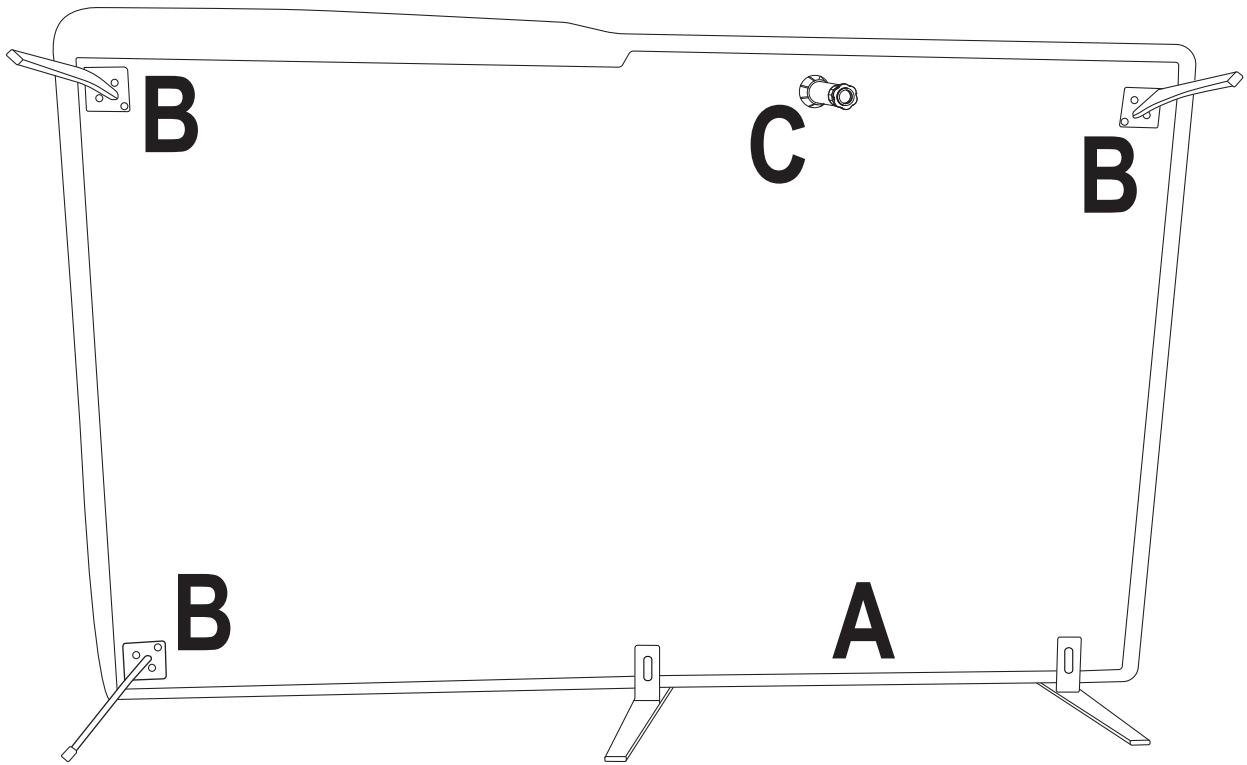
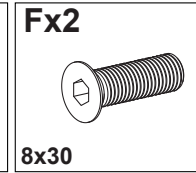
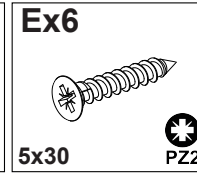
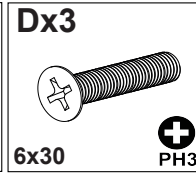
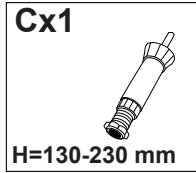
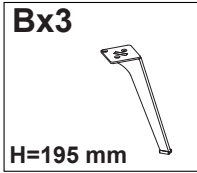
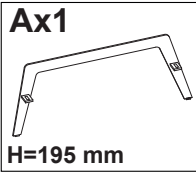

3

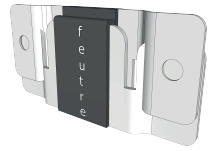
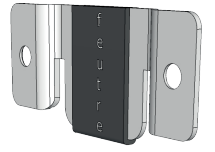
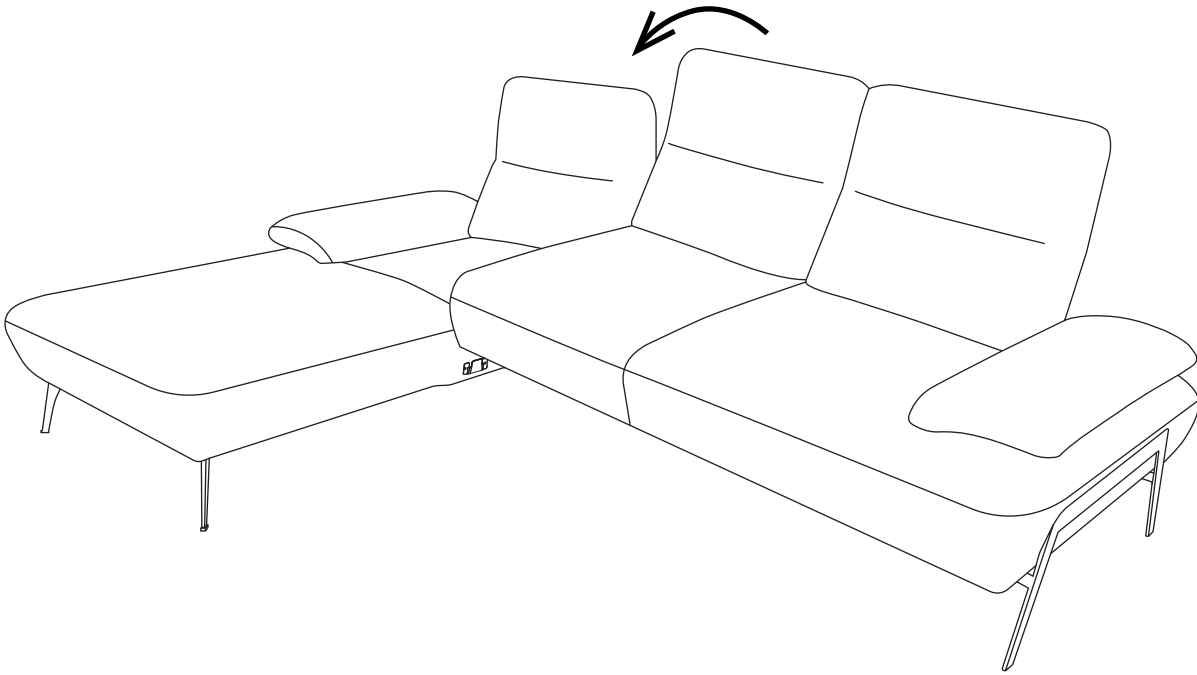

4

