

# TIRION F

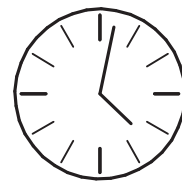

100 min

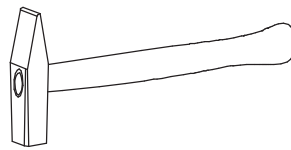

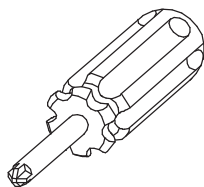
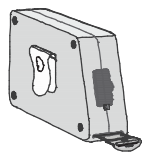
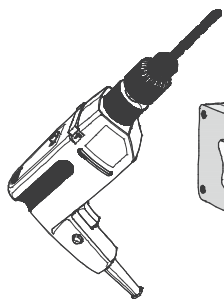
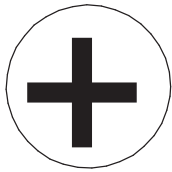
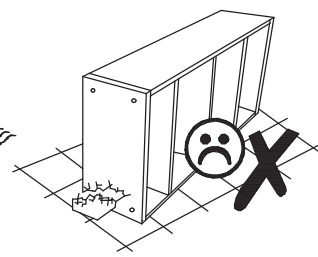
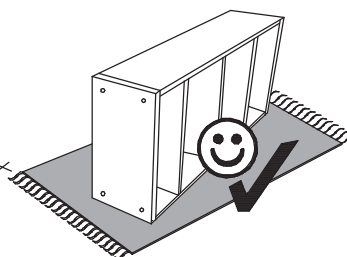
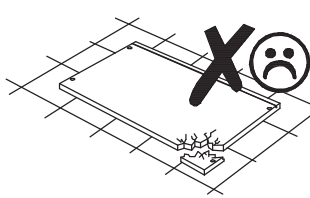
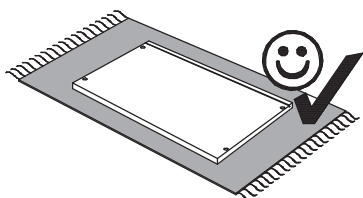
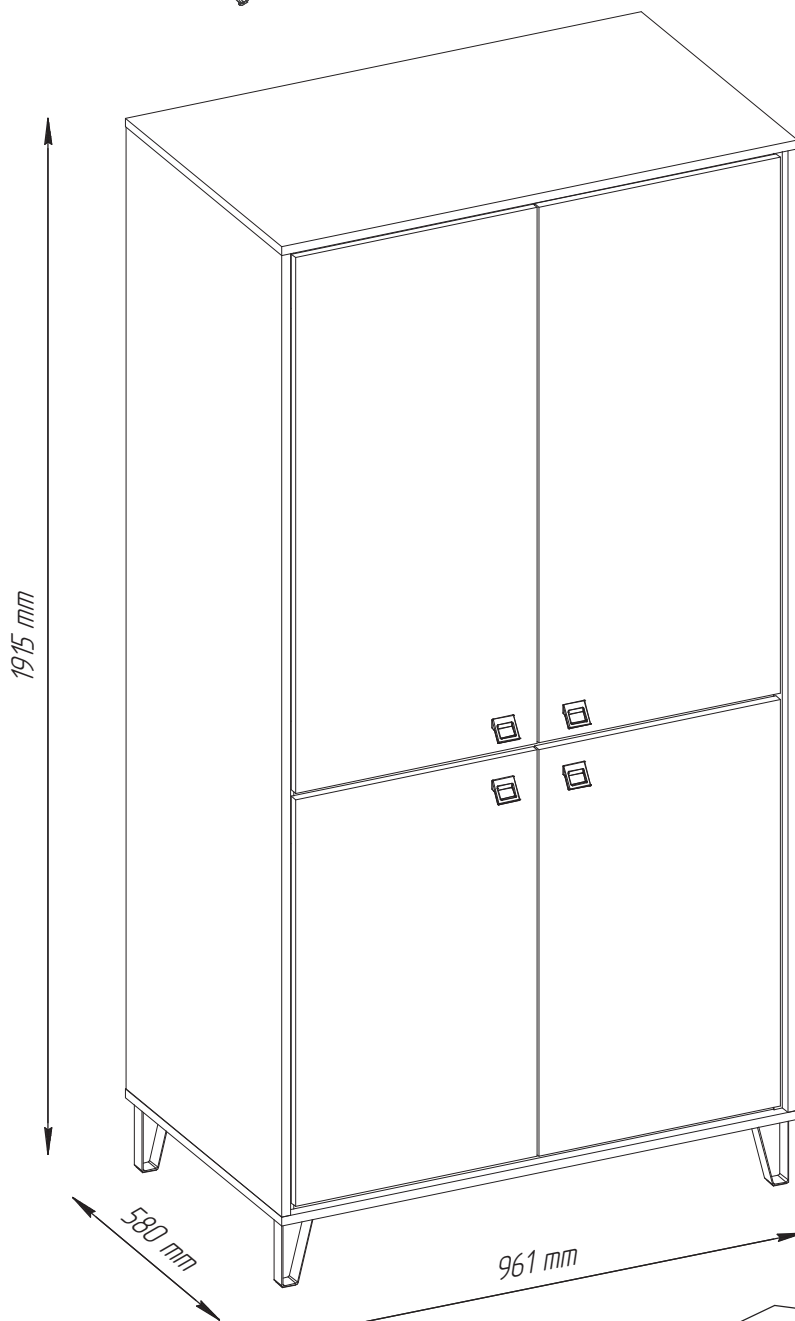
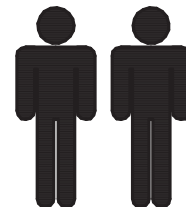
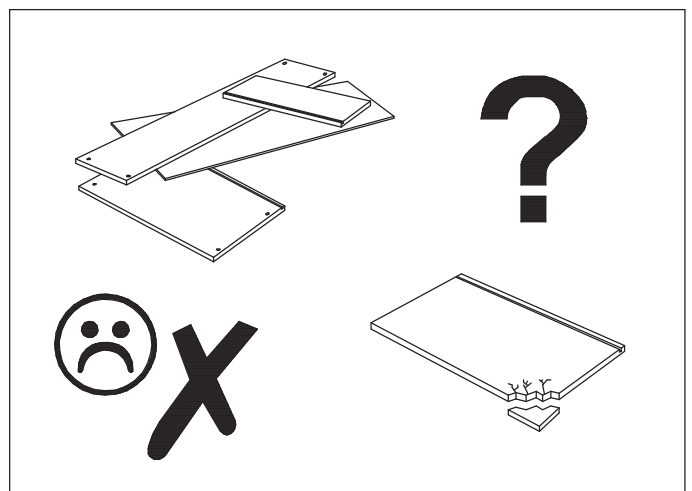
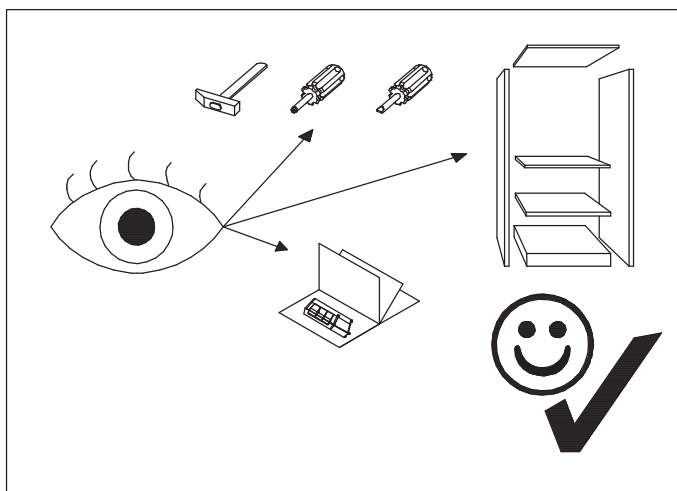
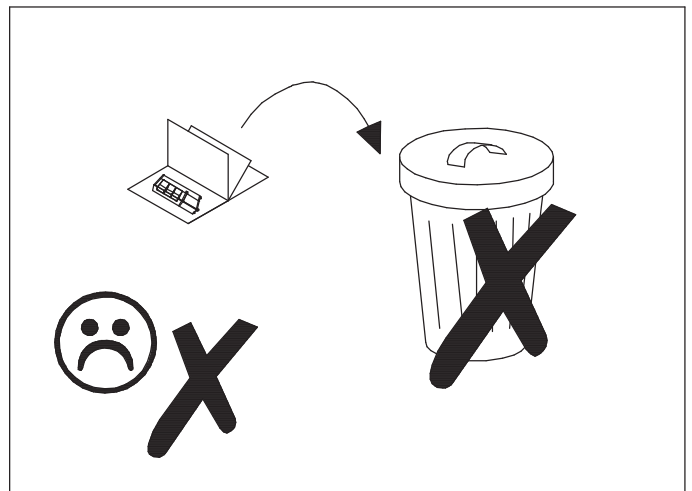
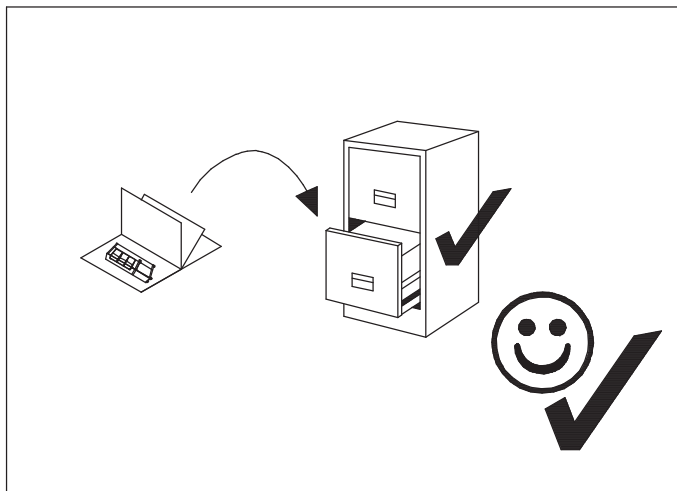
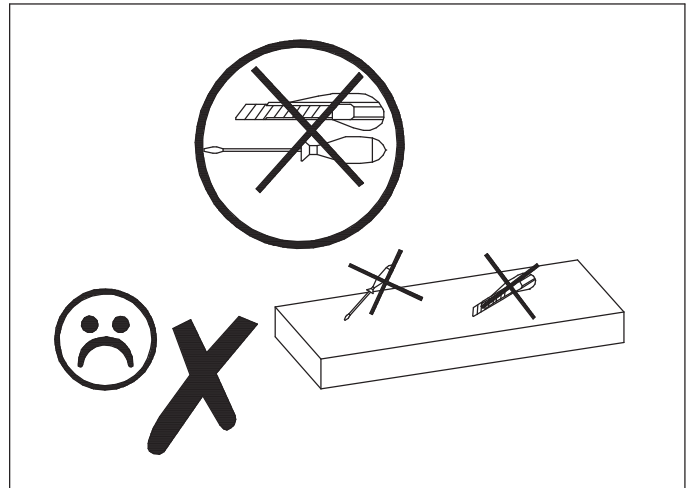
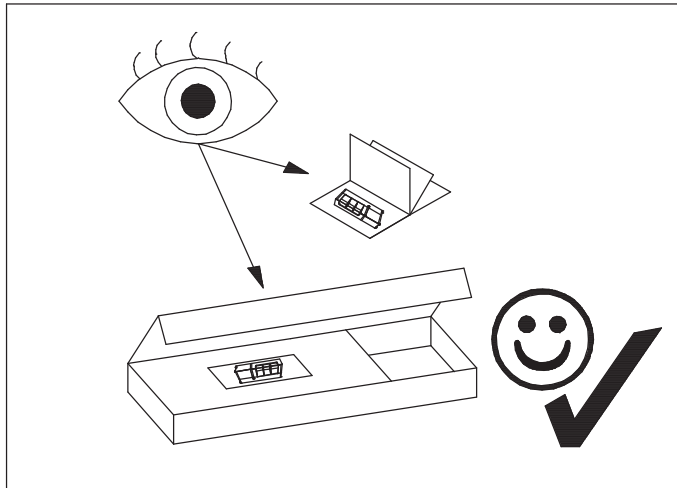

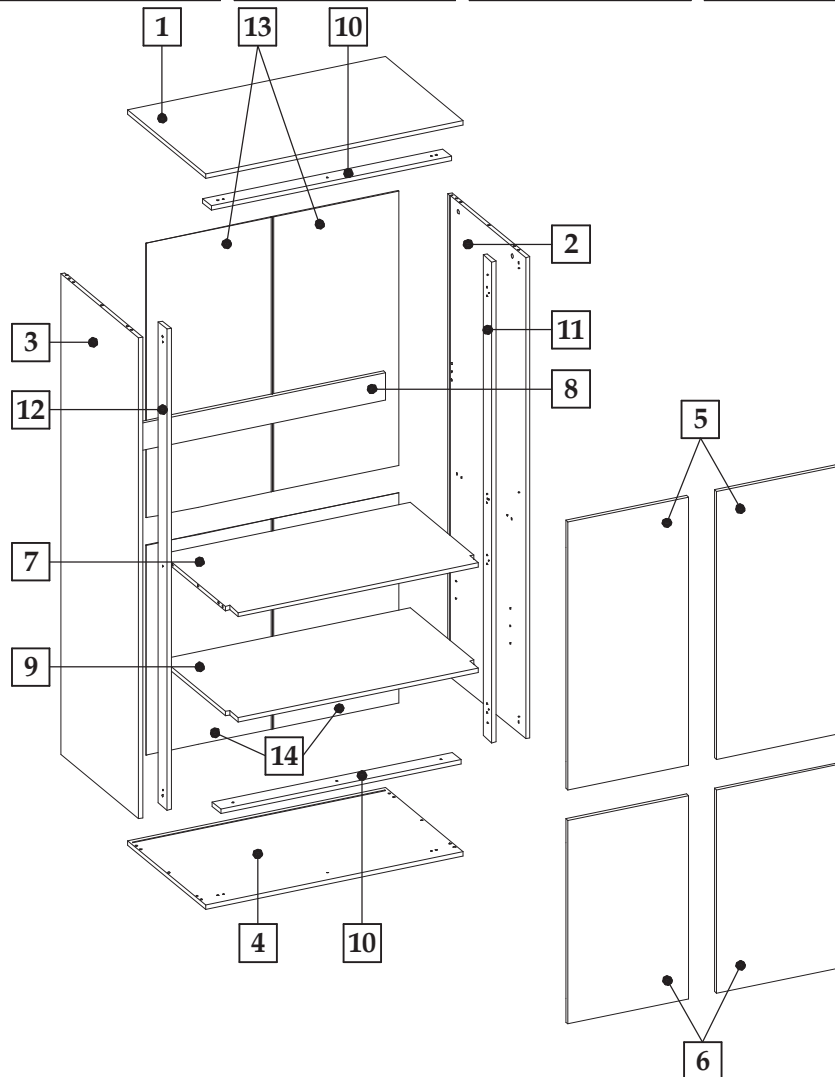
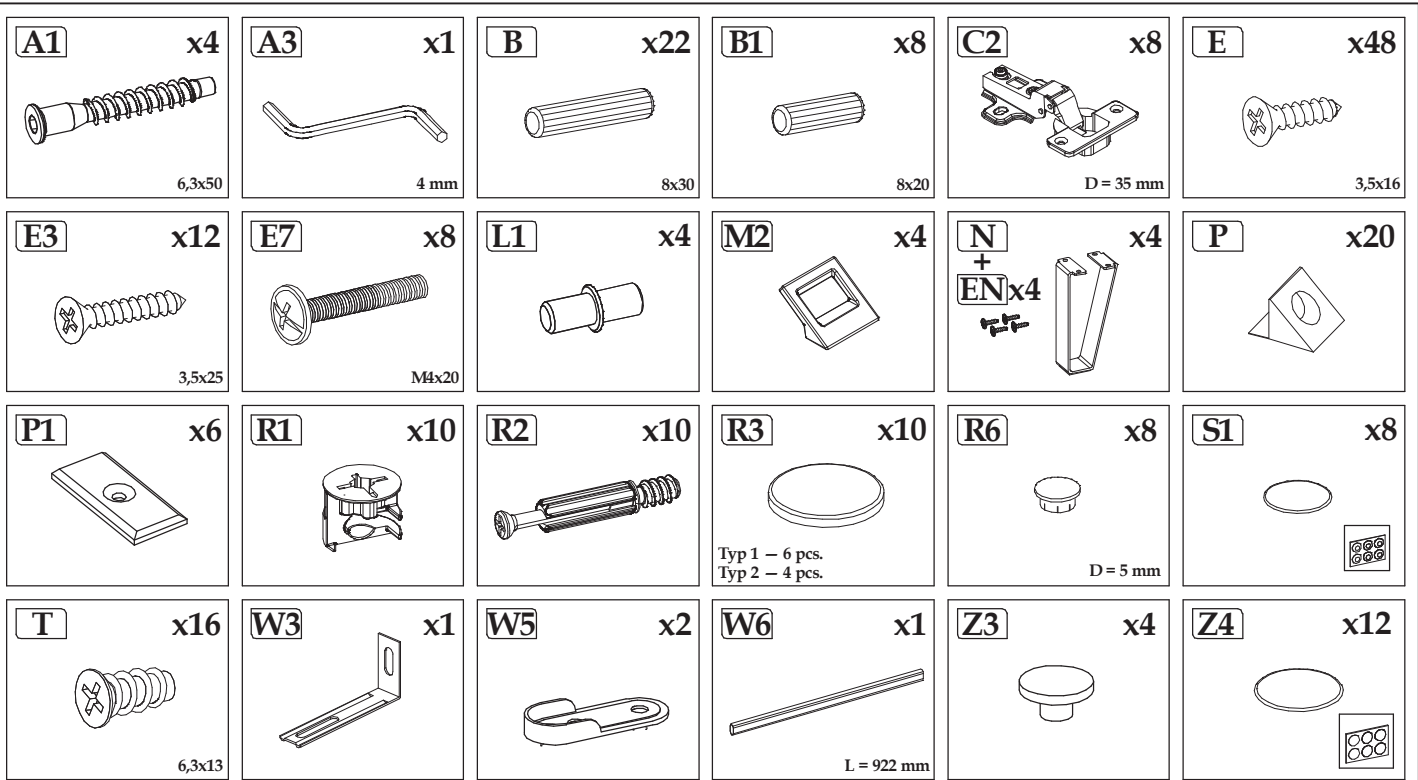

Element symbol	Measurements				Code	Pack
1	961	580	16	1	1004	1/ 2
2	1760	579	16	1	1001	2/ 2
3	1760	579	16	1	1002	2/ 2
4	961	580	16	1	1003	1/ 2
5	980	450	16	2	1015/ 1018	1/ 2
6	744	450	16	2	1014/ 1017	1/ 2
7	927	538	16	1	1007	2/ 2
8	927	100	16	1	1016	2/ 2
9	927	538	16	1	N/ A	2/ 2
10	895	64	16	2	1012/ 1013	2/ 2
11	1760	65	16	1	1010	2/ 2
12	1760	65	16	1	1011	2/ 2
13	1005	472	16	2	N/ A	1/ 2
14	768	472	16	2	N/ A	1/ 2

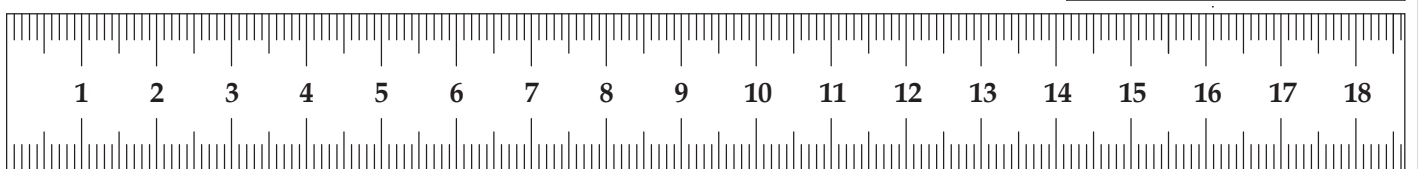
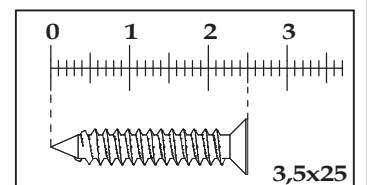

▶ 1

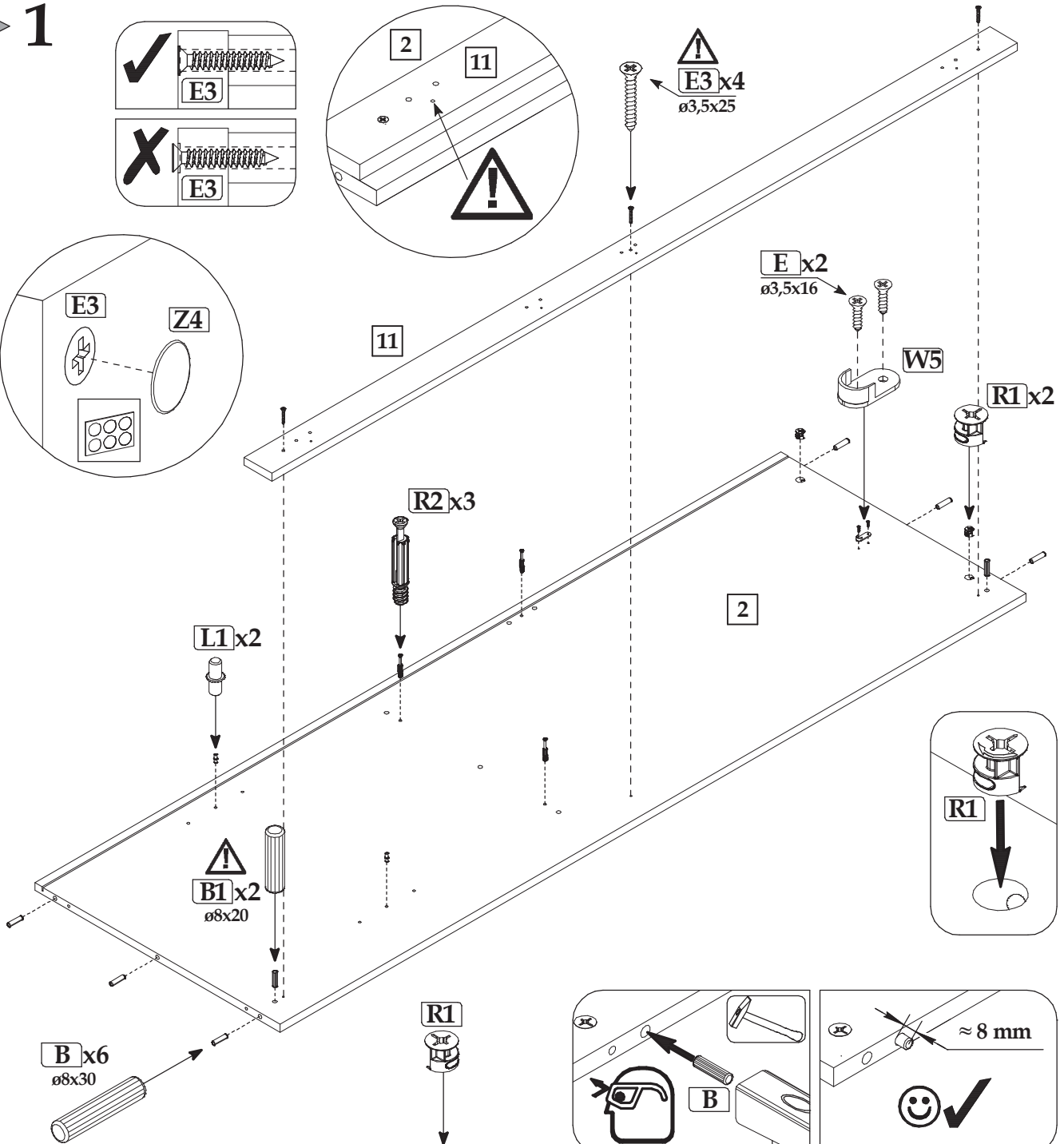
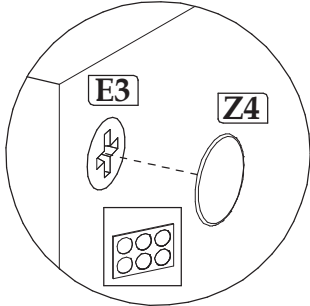
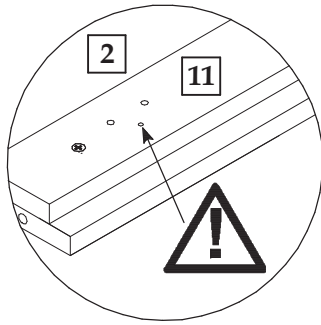
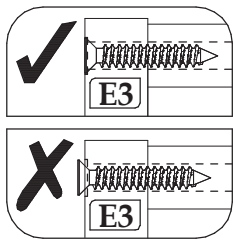

▶ 2

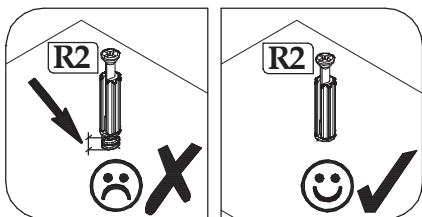
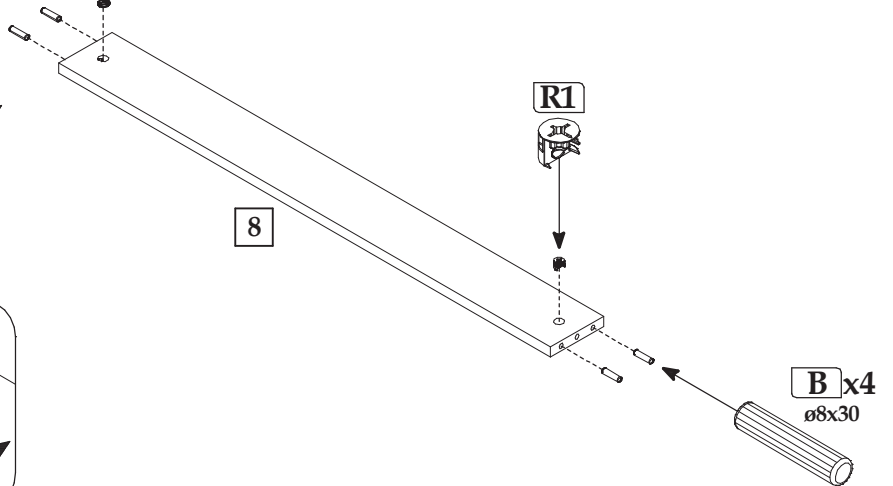
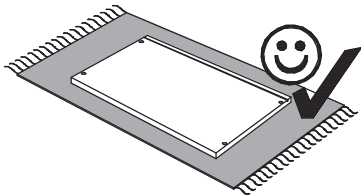

▶ 3

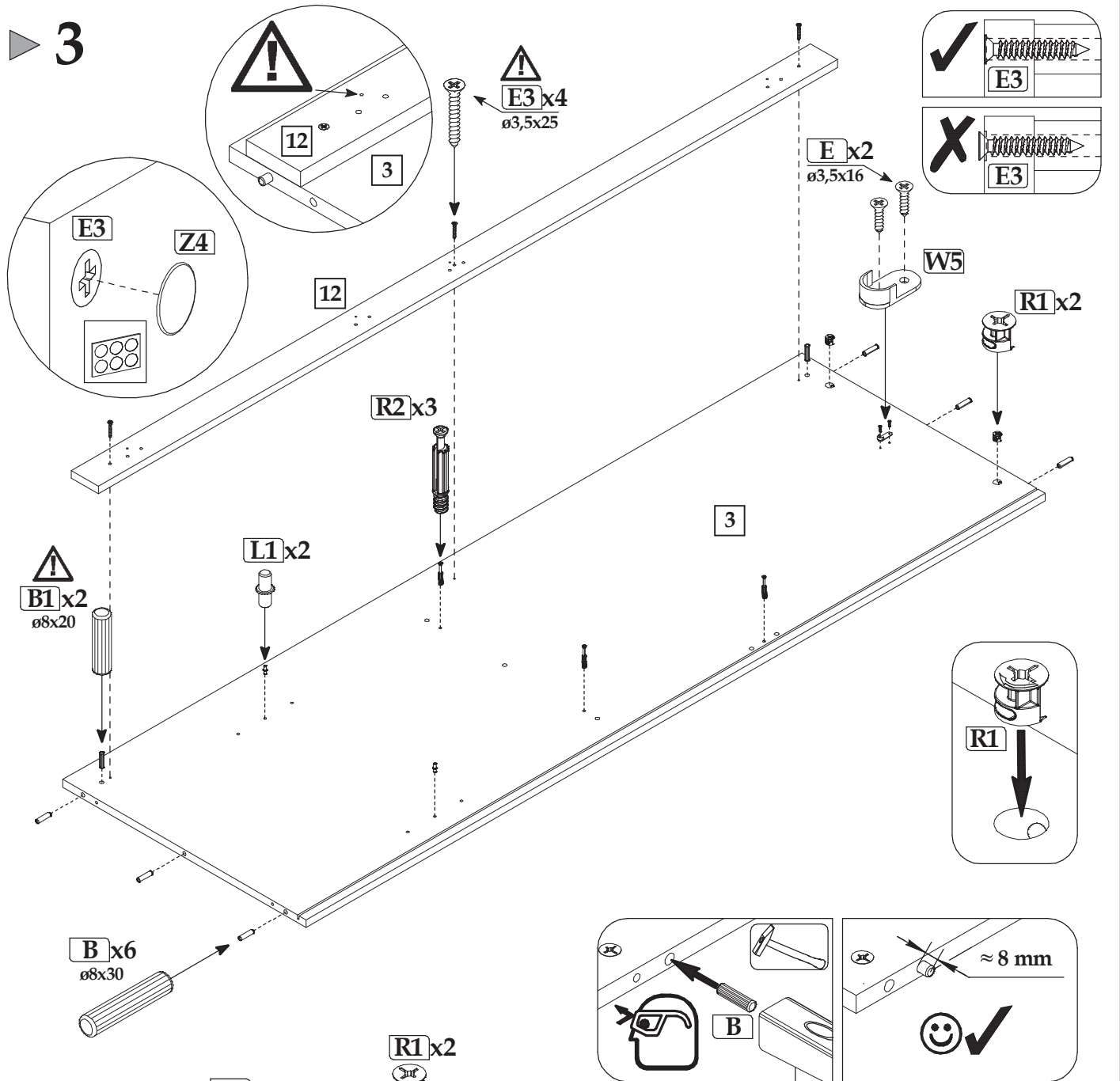

▶ 4

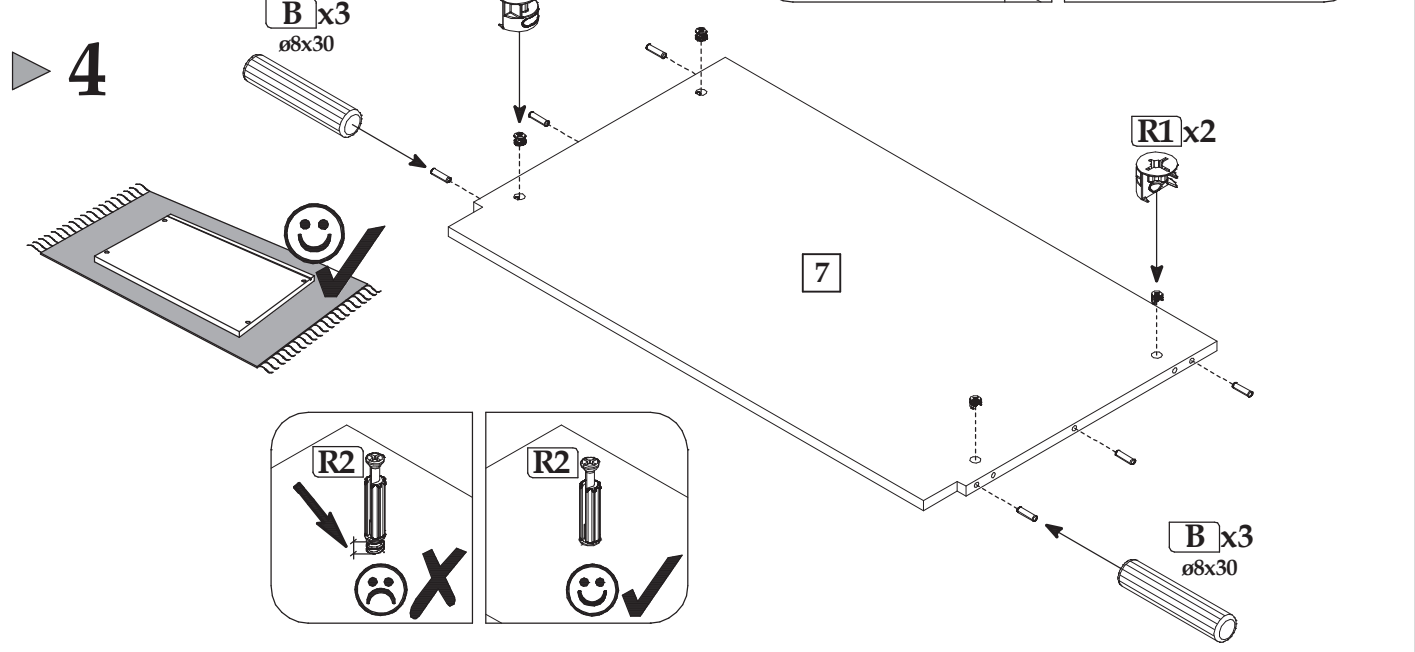

▶ 5

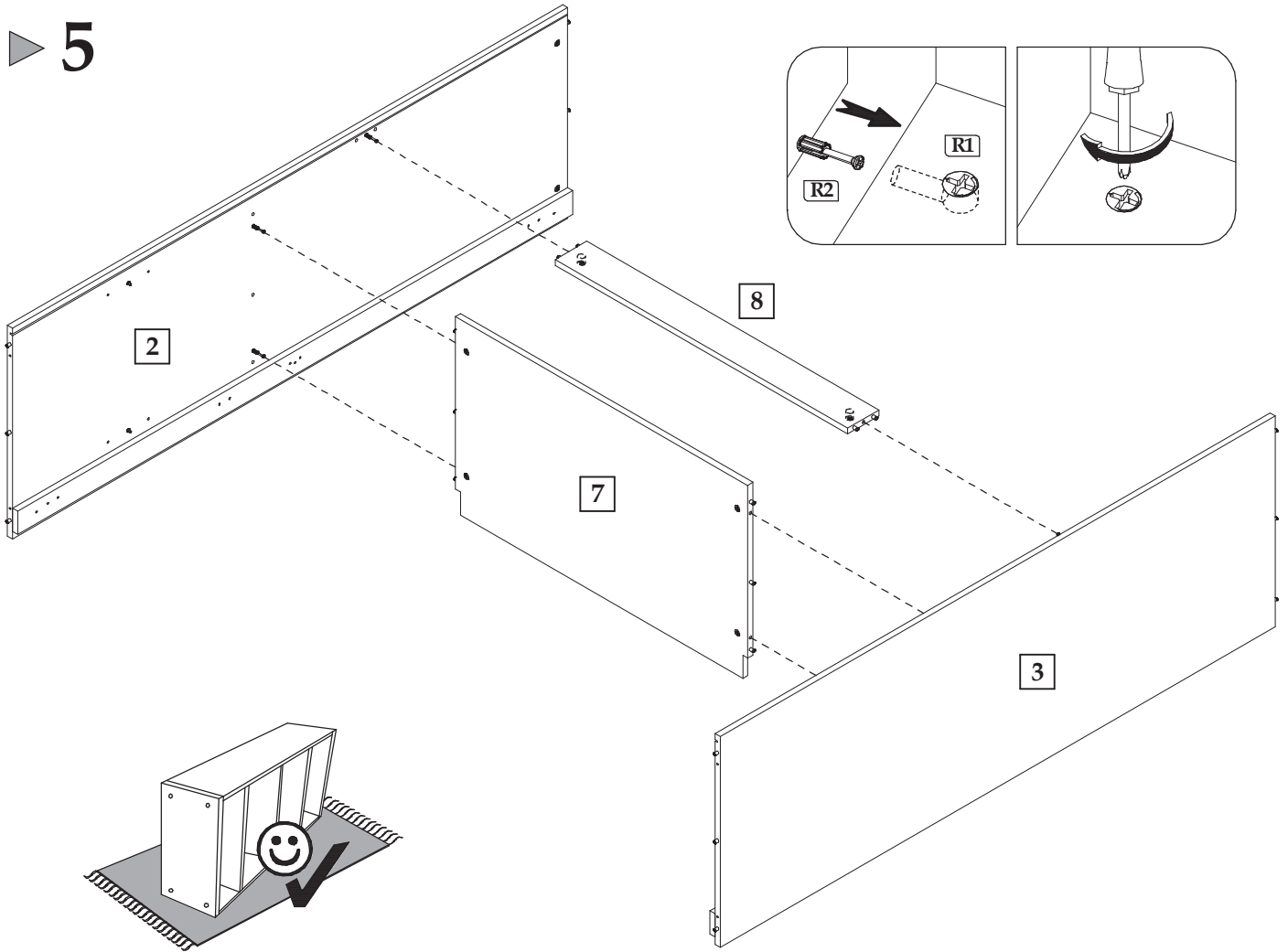

▶ 6

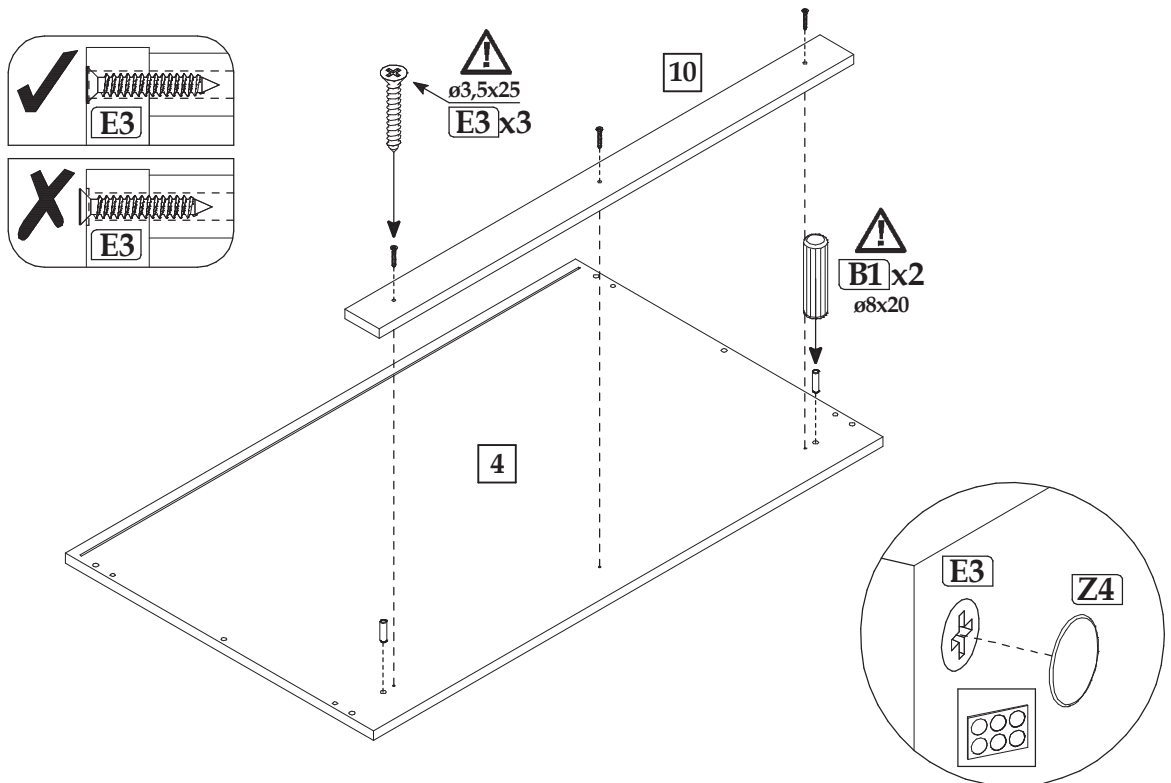

▶ 7

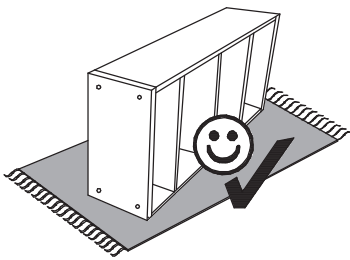
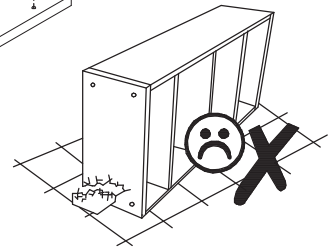
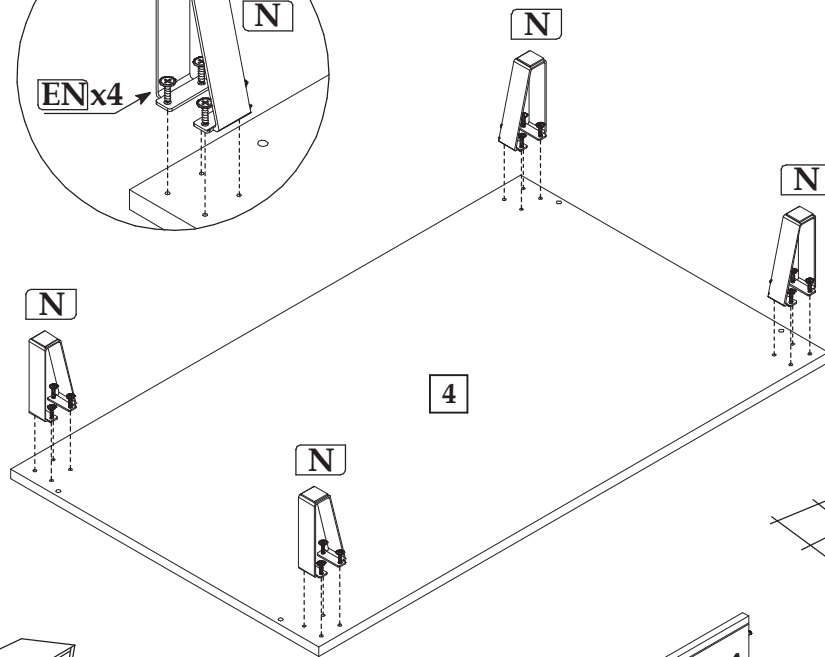
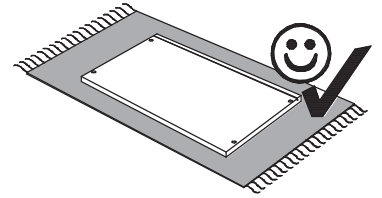
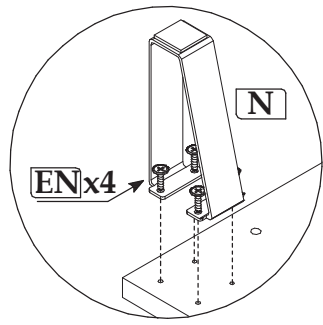

▶ 8

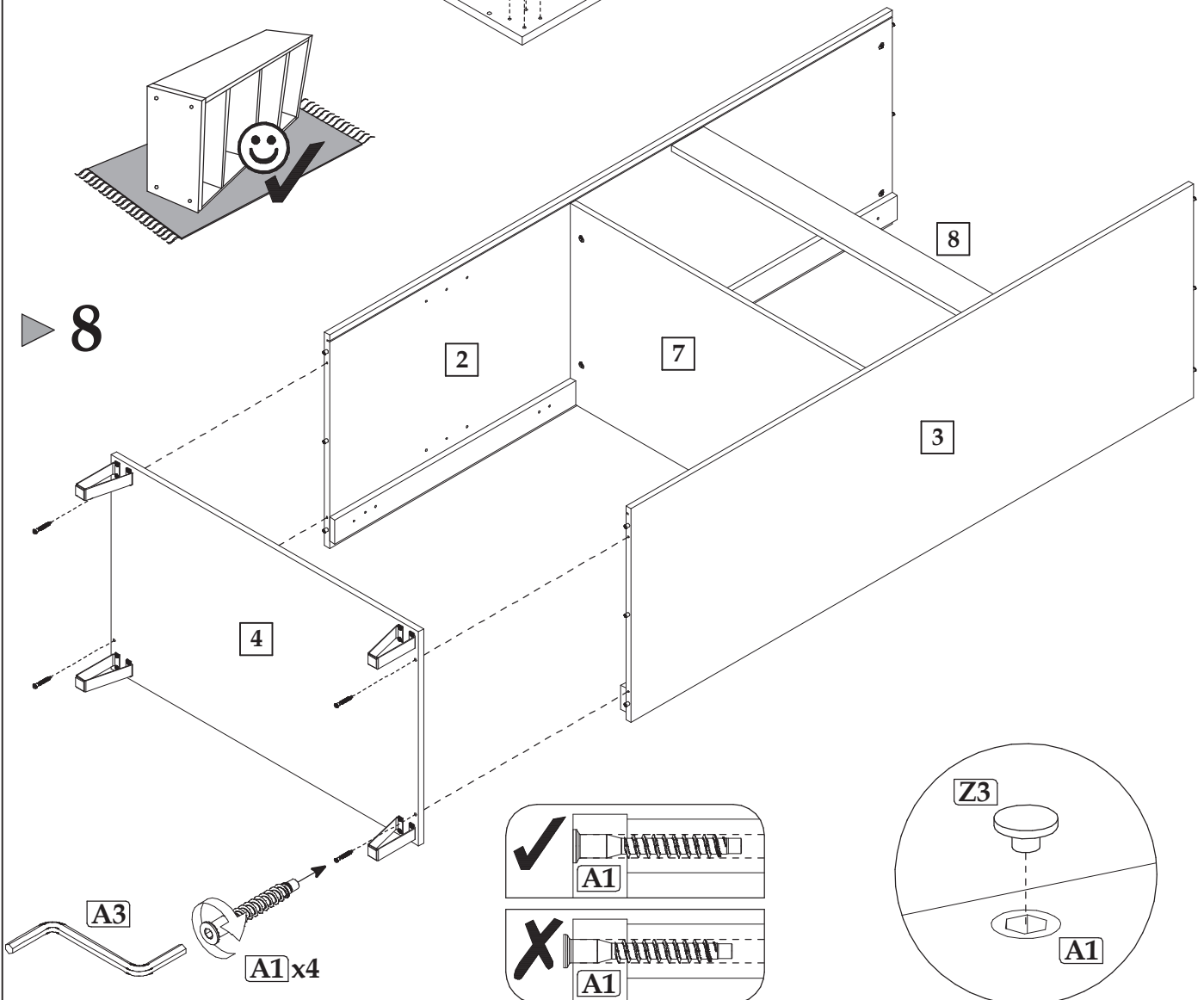

▶ 9

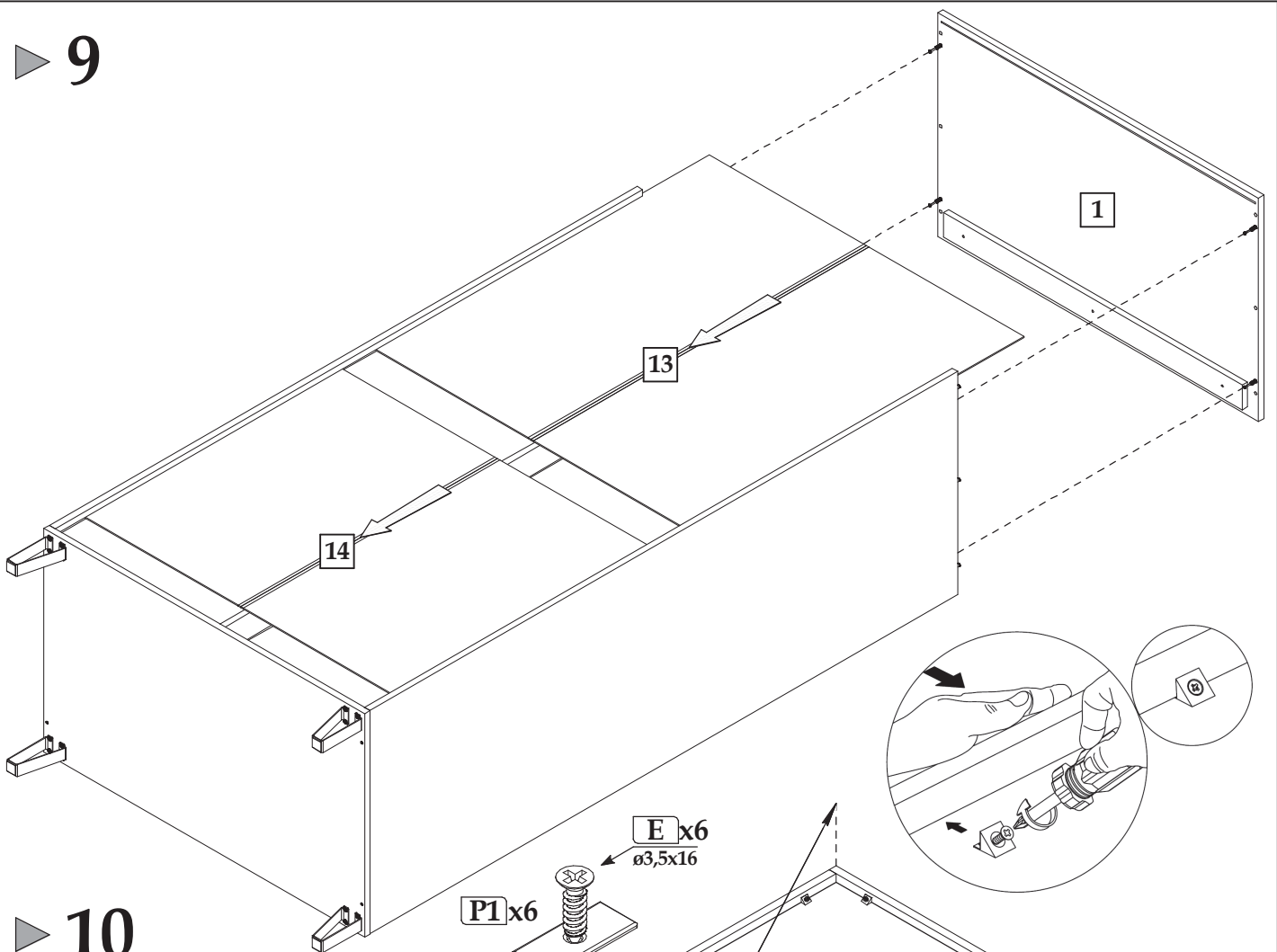

▶ 10

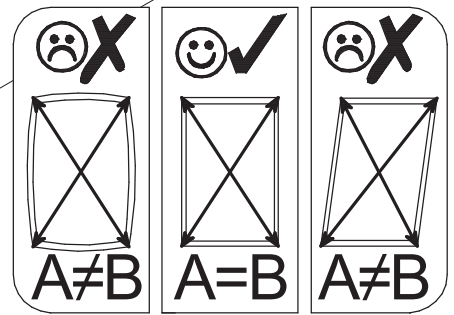
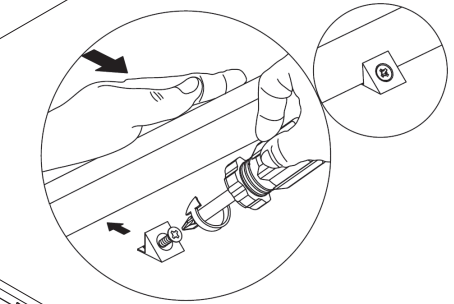
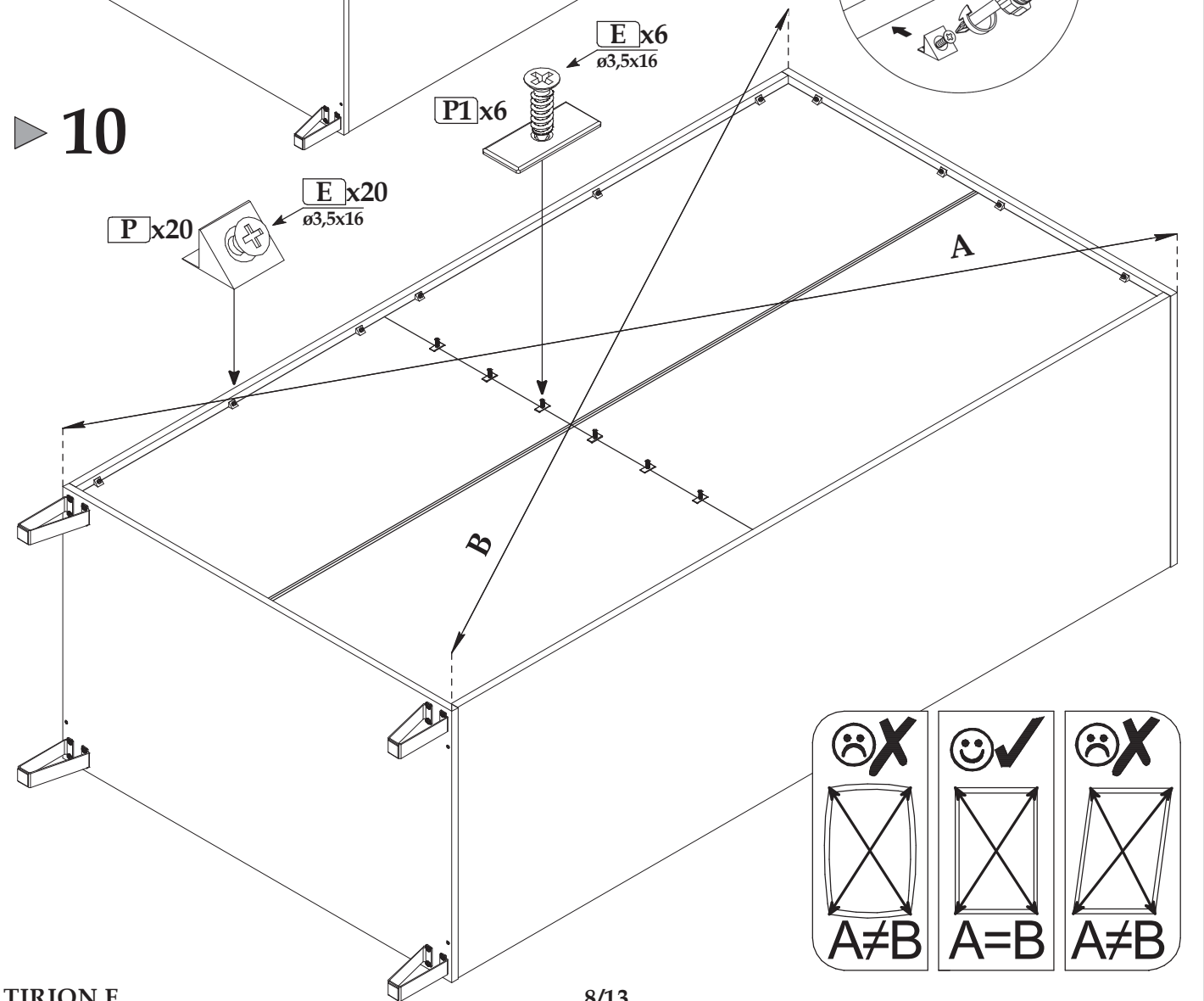



▶ 11

x2

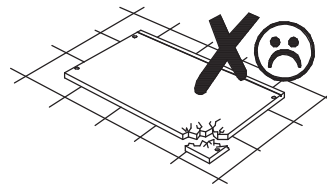
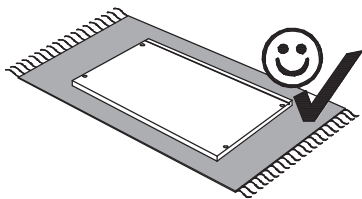
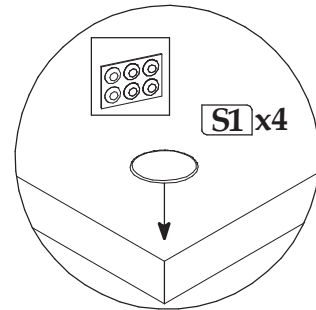
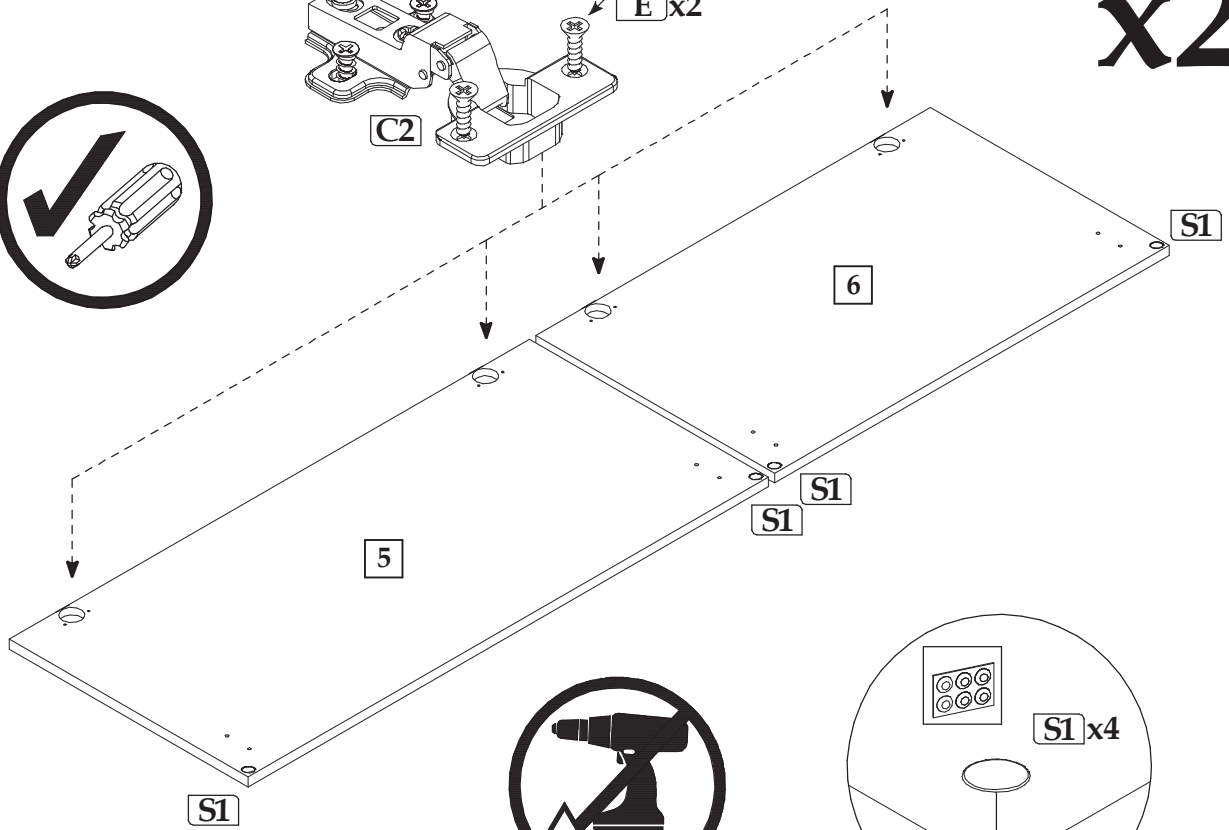
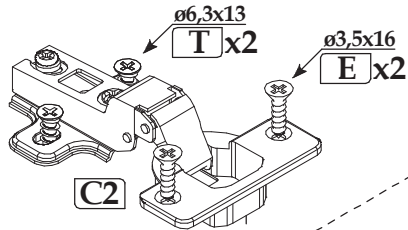
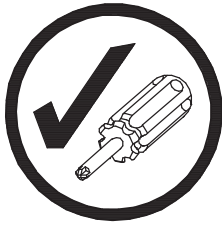

<p>+ 2 mm - 2 mm</p>	<p>+ 3 mm - 1 mm</p>	<p>+ 5 mm - 1,5 mm</p>

▶ 12

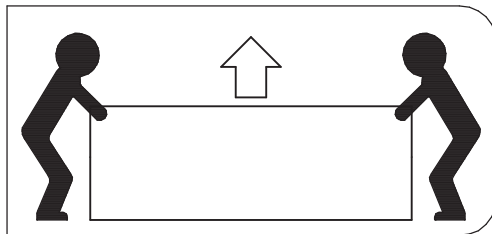
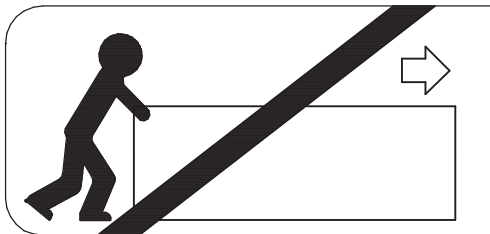
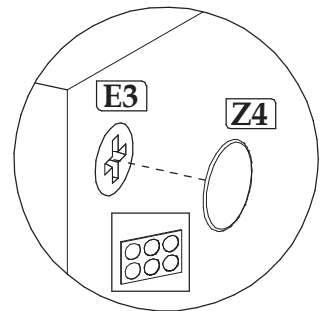
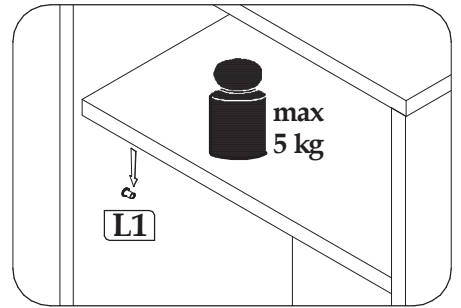
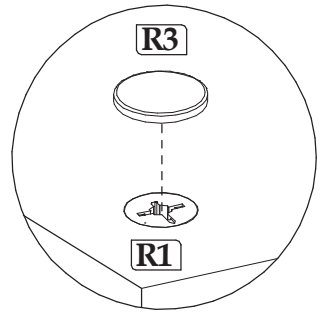
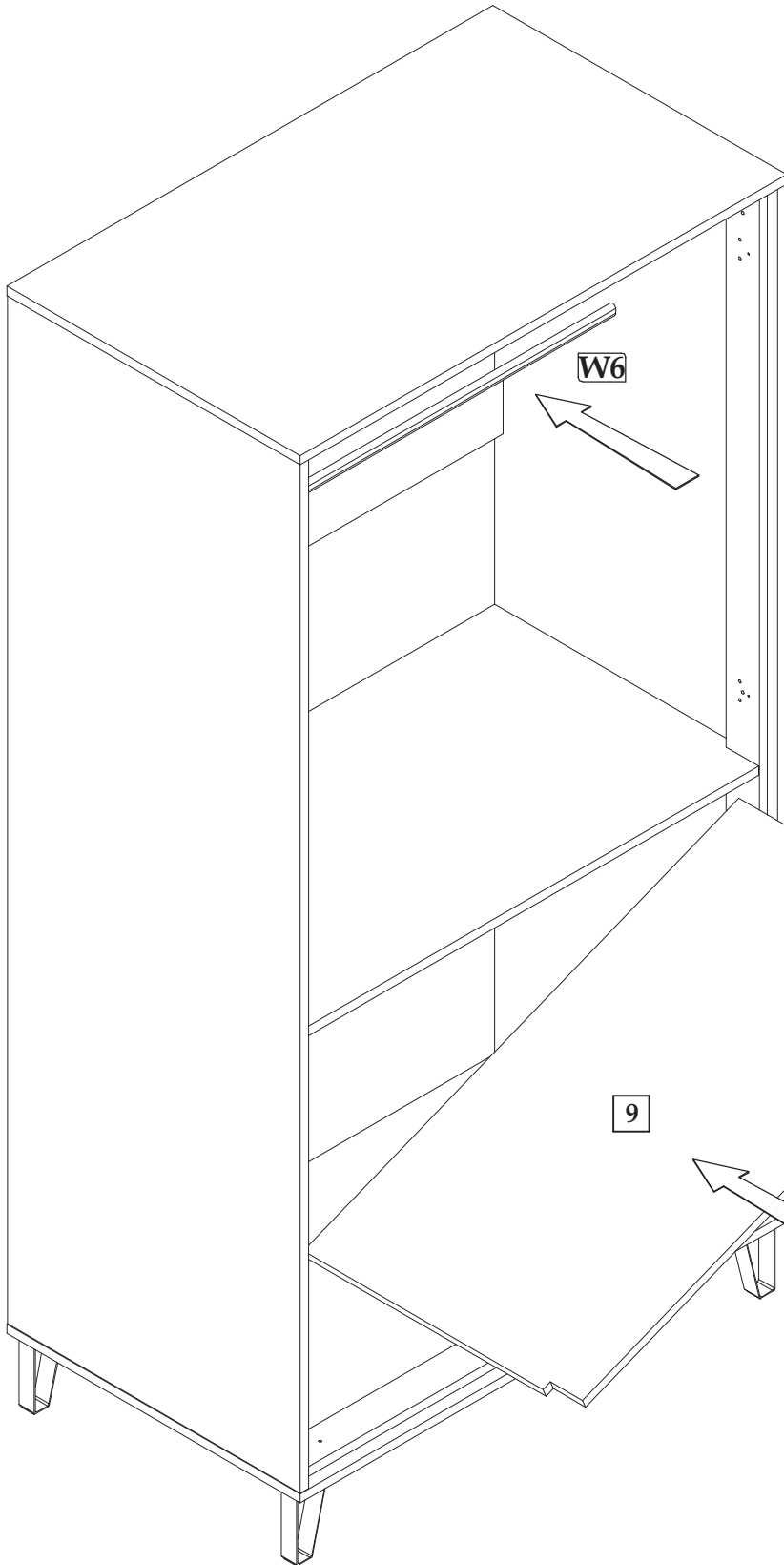

▶ 13

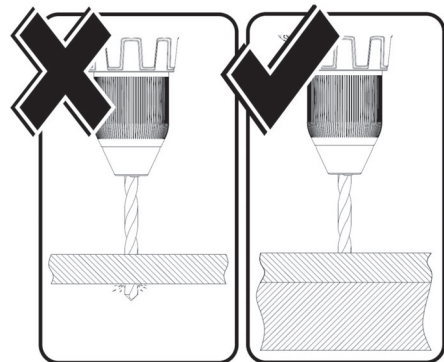
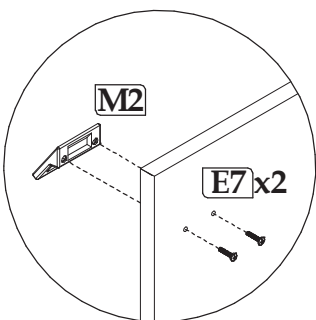
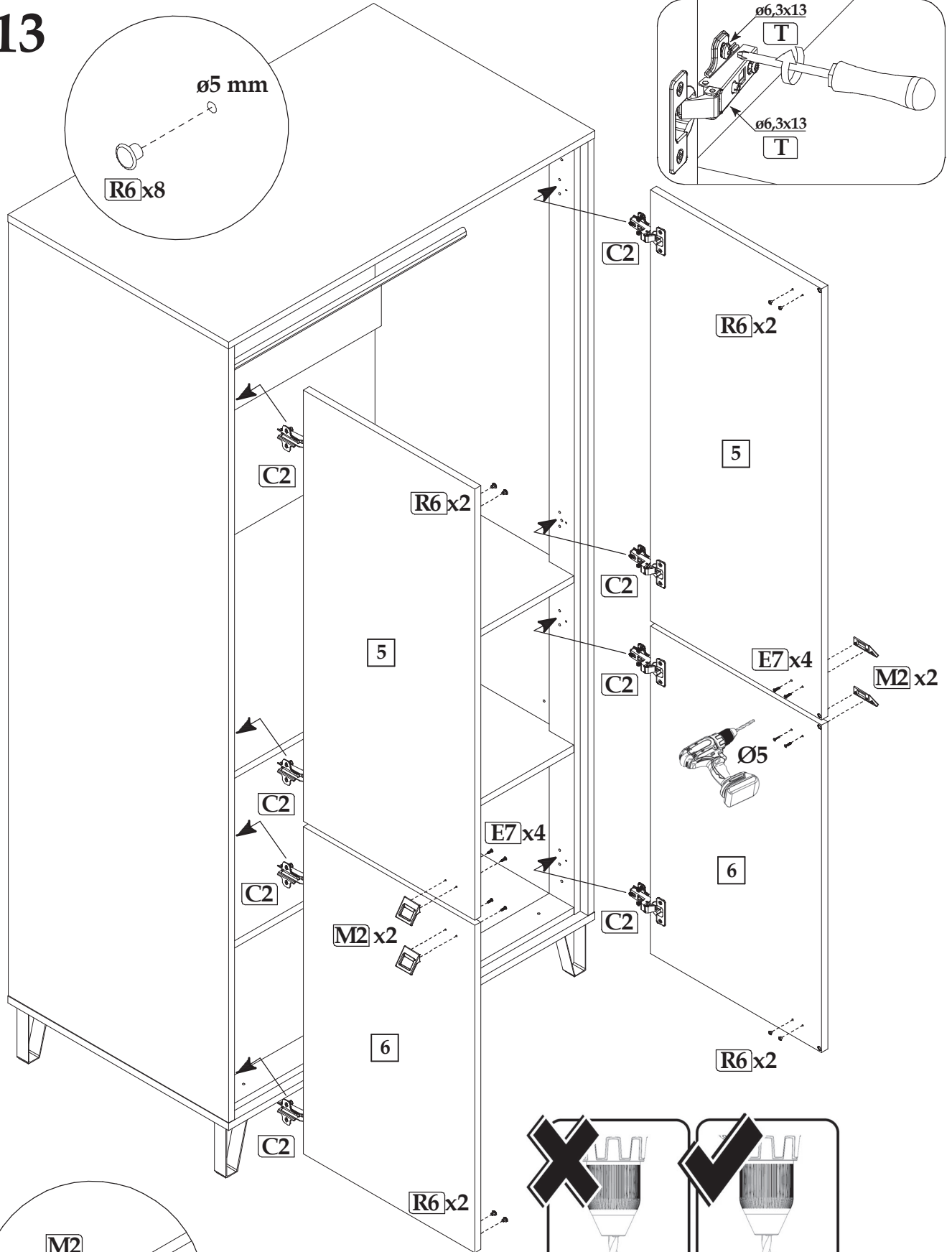
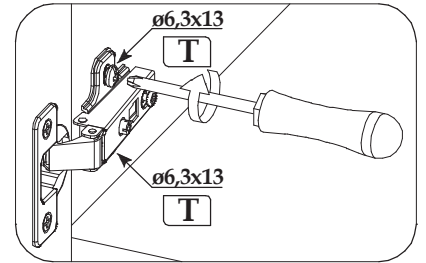
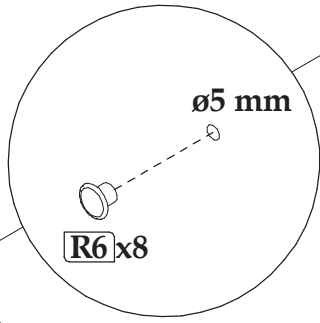

▶ 14

