

TIRION R

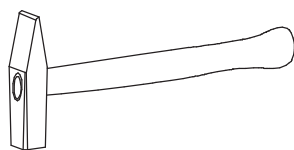

1915 mm

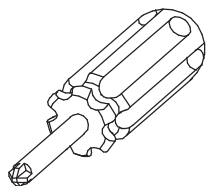

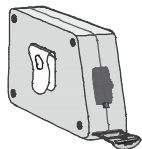
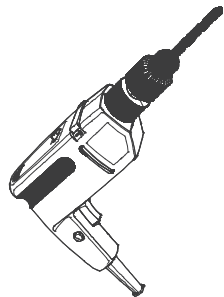
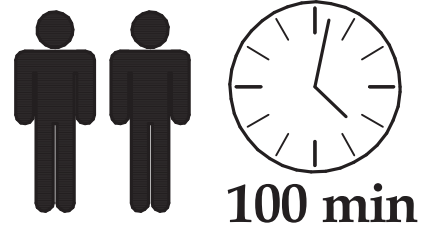
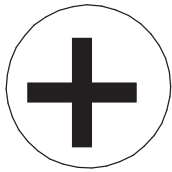
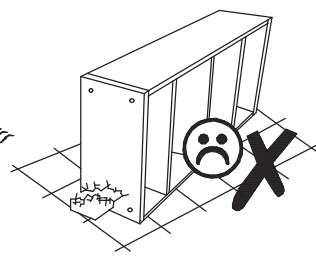
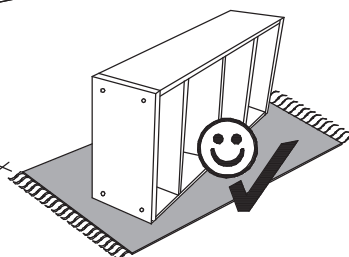
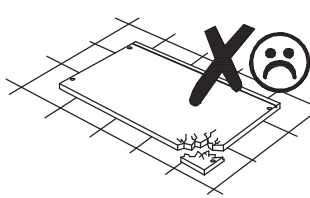
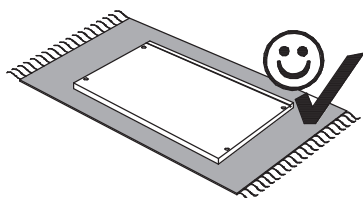
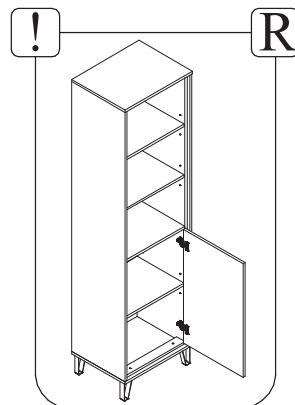
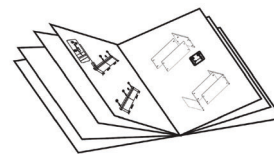
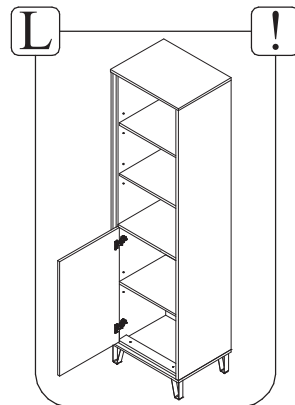
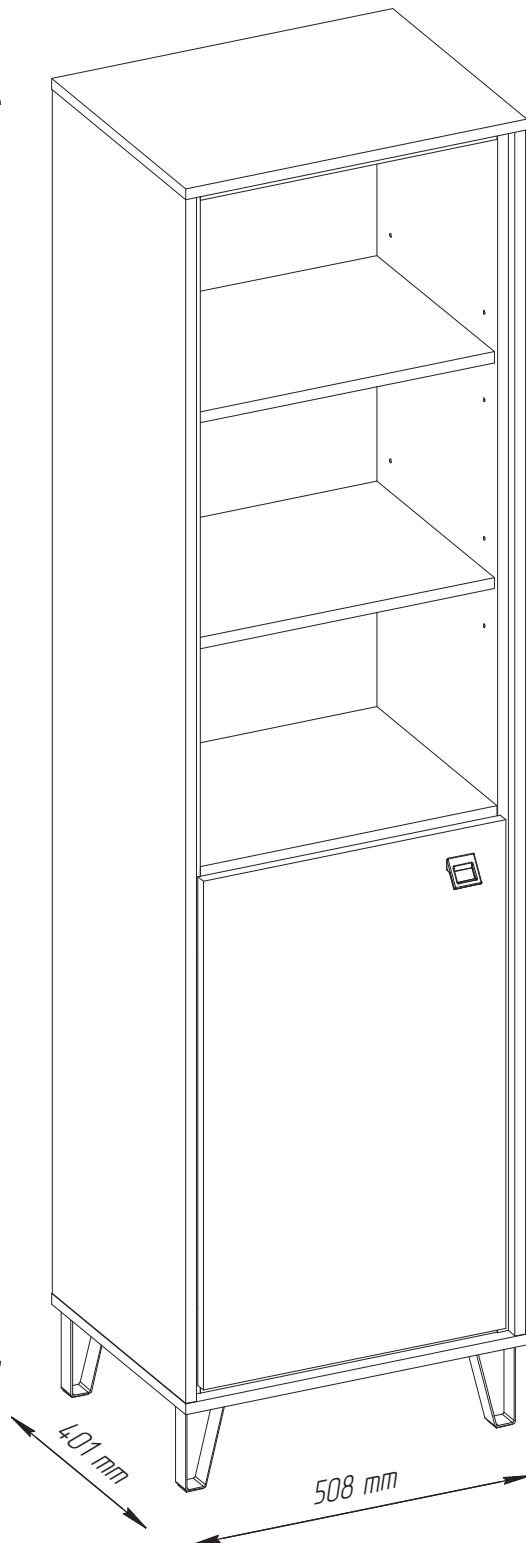
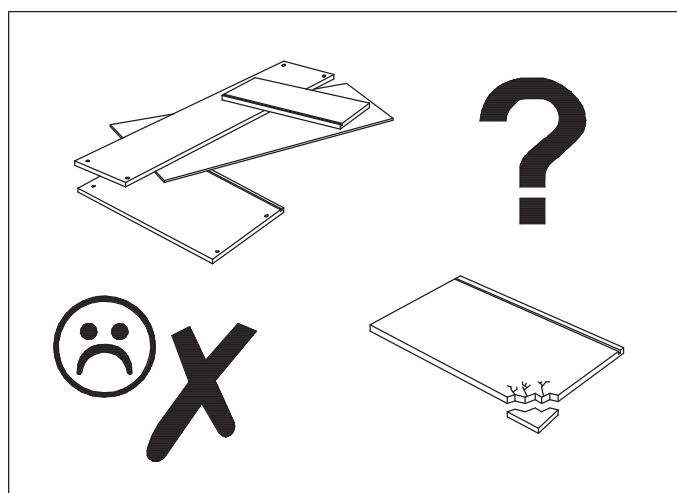
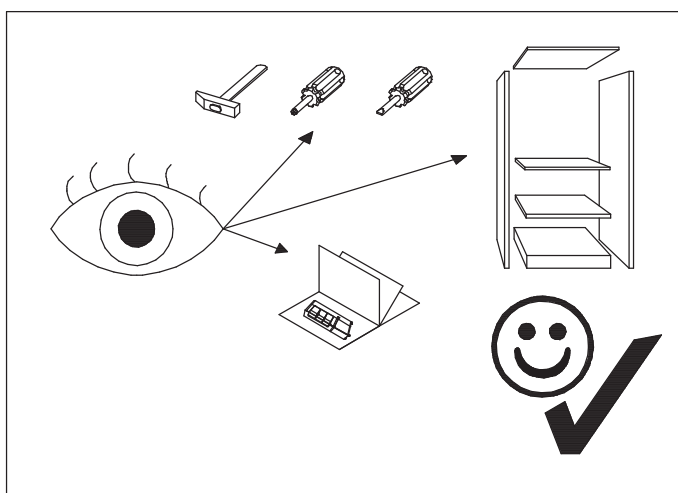
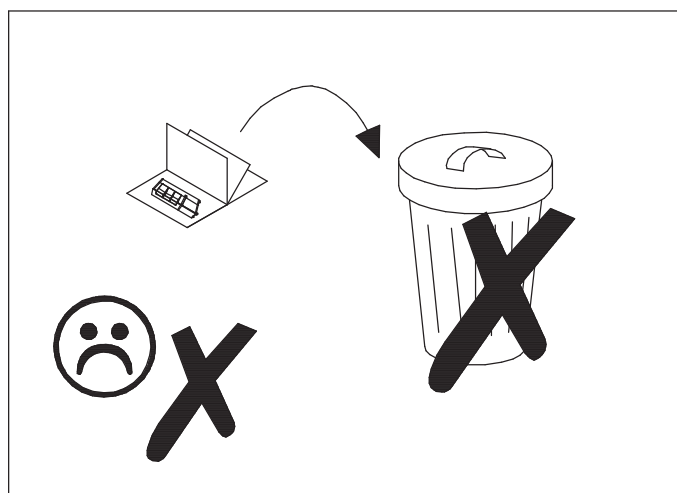
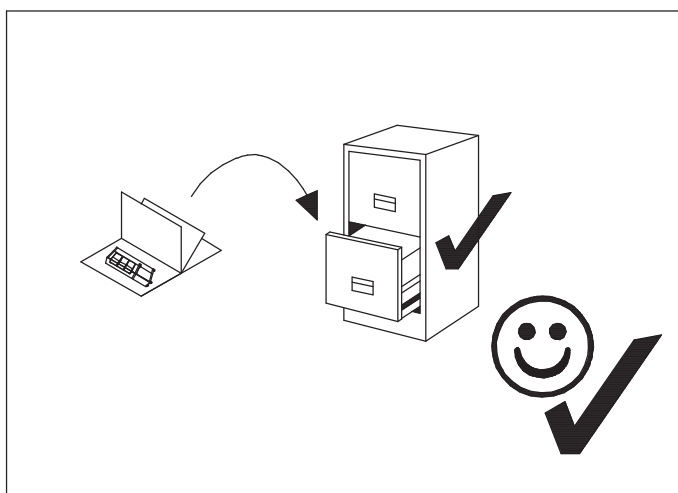
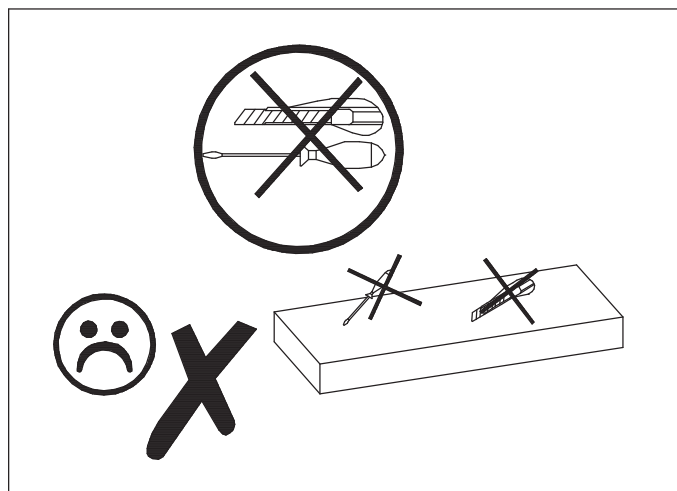
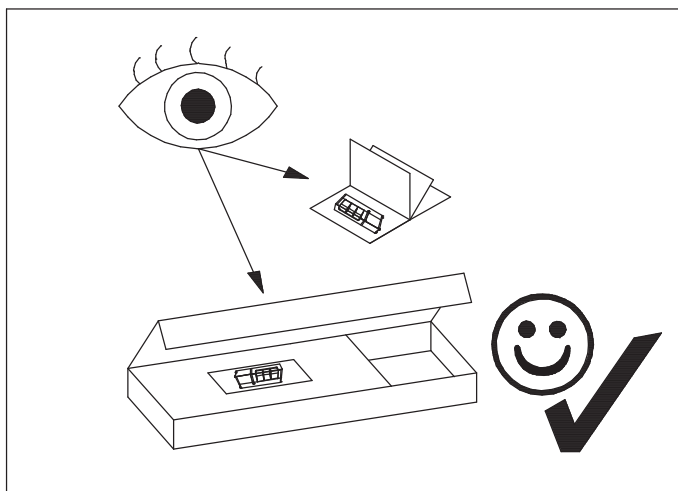

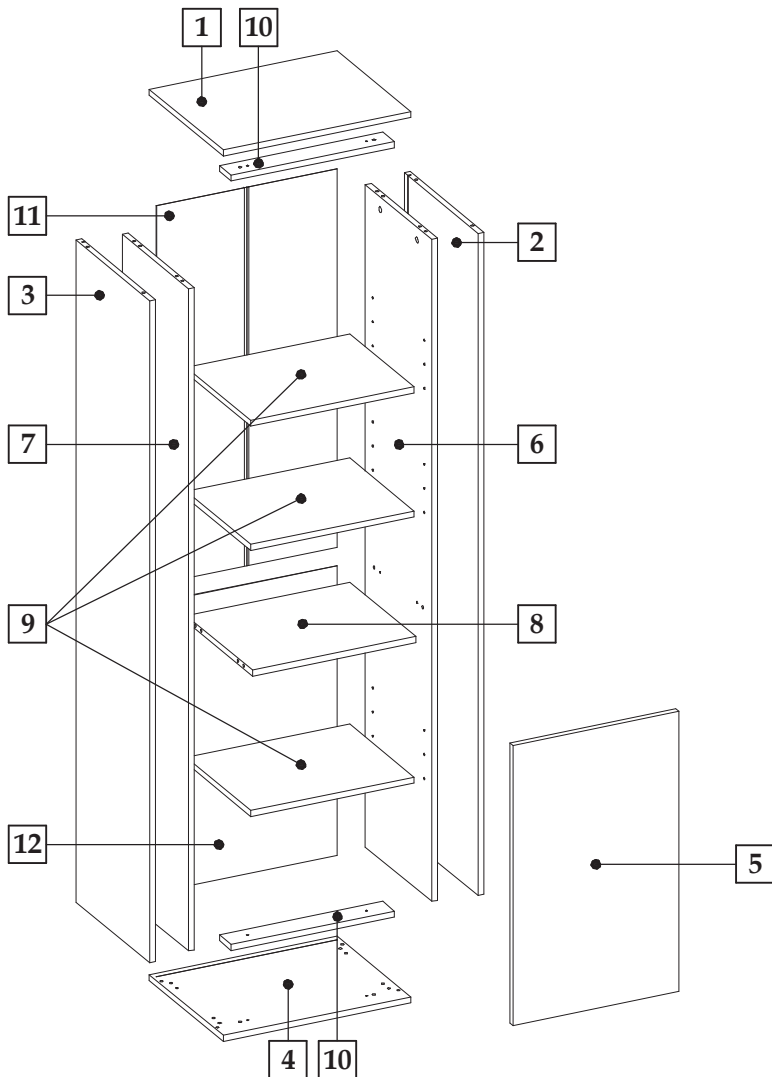
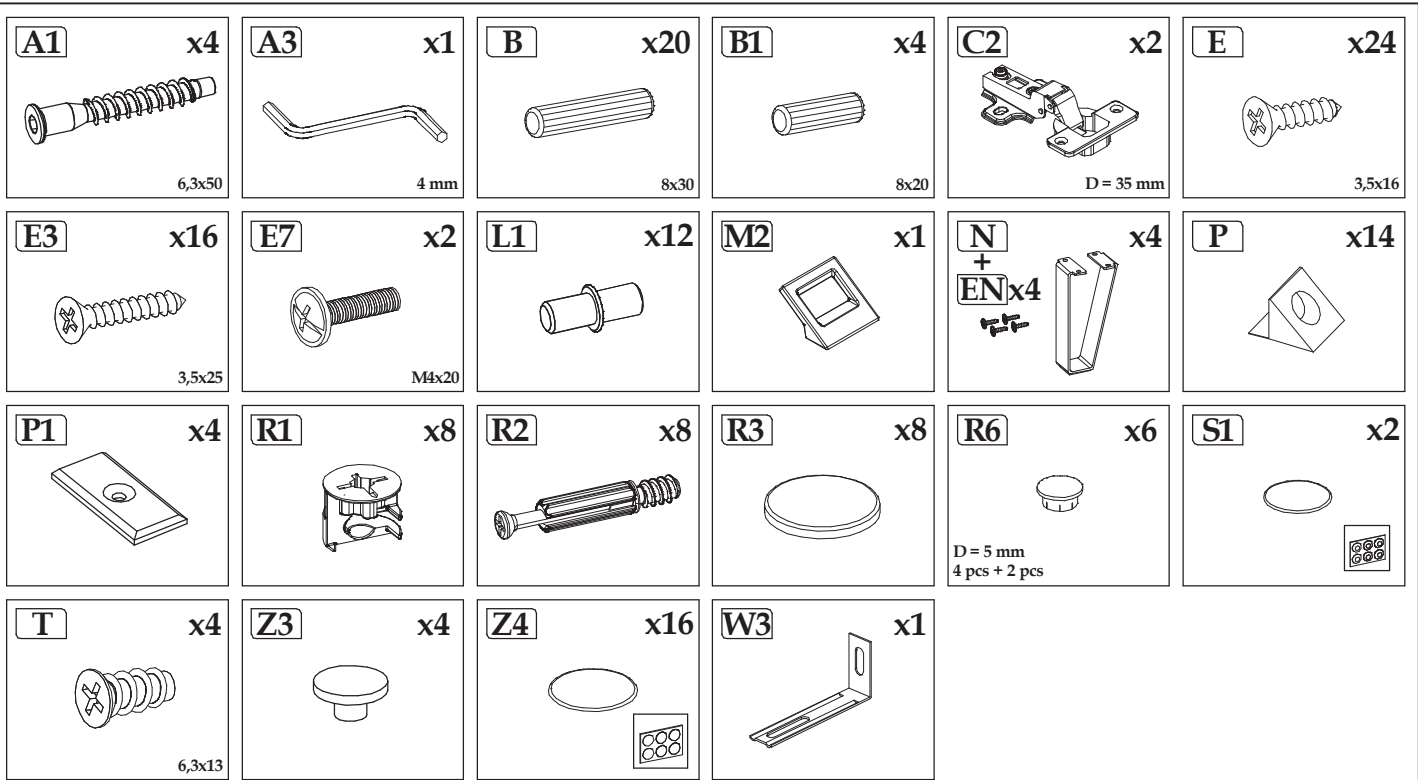

Element symbol	Measurements				Code	Pack
	1	2	3	4		
1	508	401	16	1	1004	2/ 2
2	1760	400	16	1	1001	1/ 2
3	1760	400	16	1	1002	1/ 2
4	508	401	16	1	1003	2/ 2
5	744	450	16	1	1010	2/ 2
6	1760	360	16	1	1007	1/ 2
7	1760	360	16	1	1006	1/ 2
8	442	359	16	1	1011	1/ 2
9	442	350	16	3	N/ A	1/ 2
10	442	64	16	2	1008/ 1015	2/ 2
11	1005	246	3	2	N/ A	1/ 2
12	766	488	3	1	N/ A	2/ 2

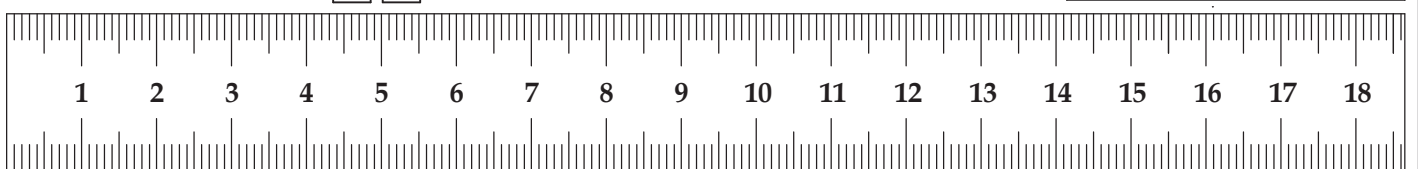
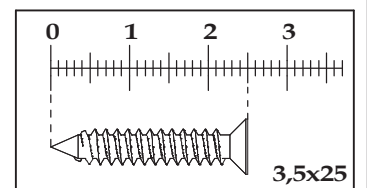

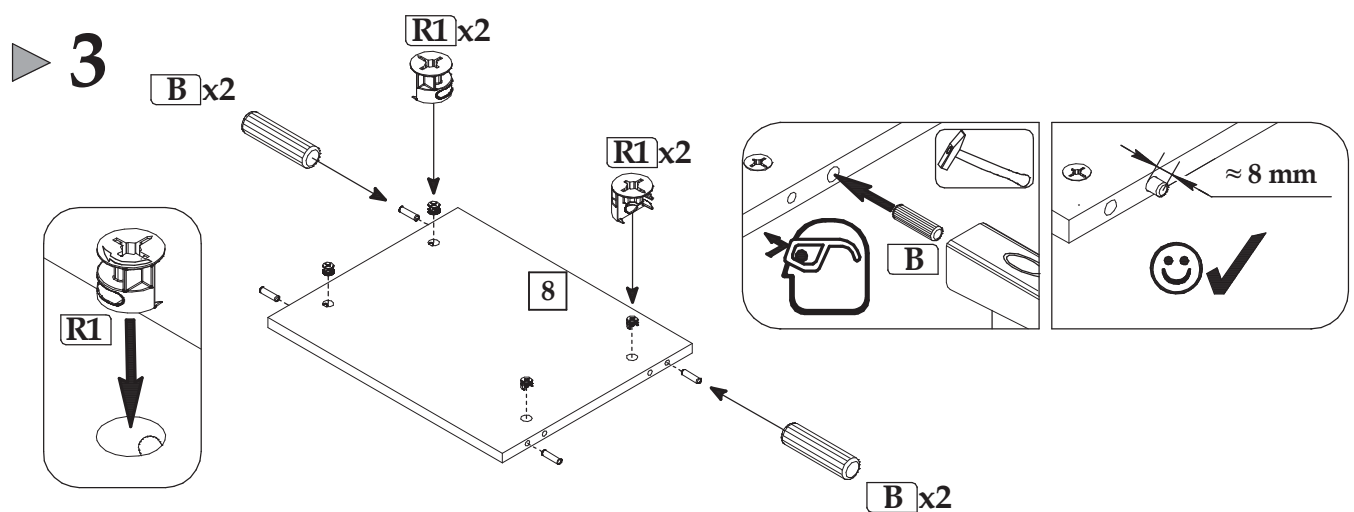
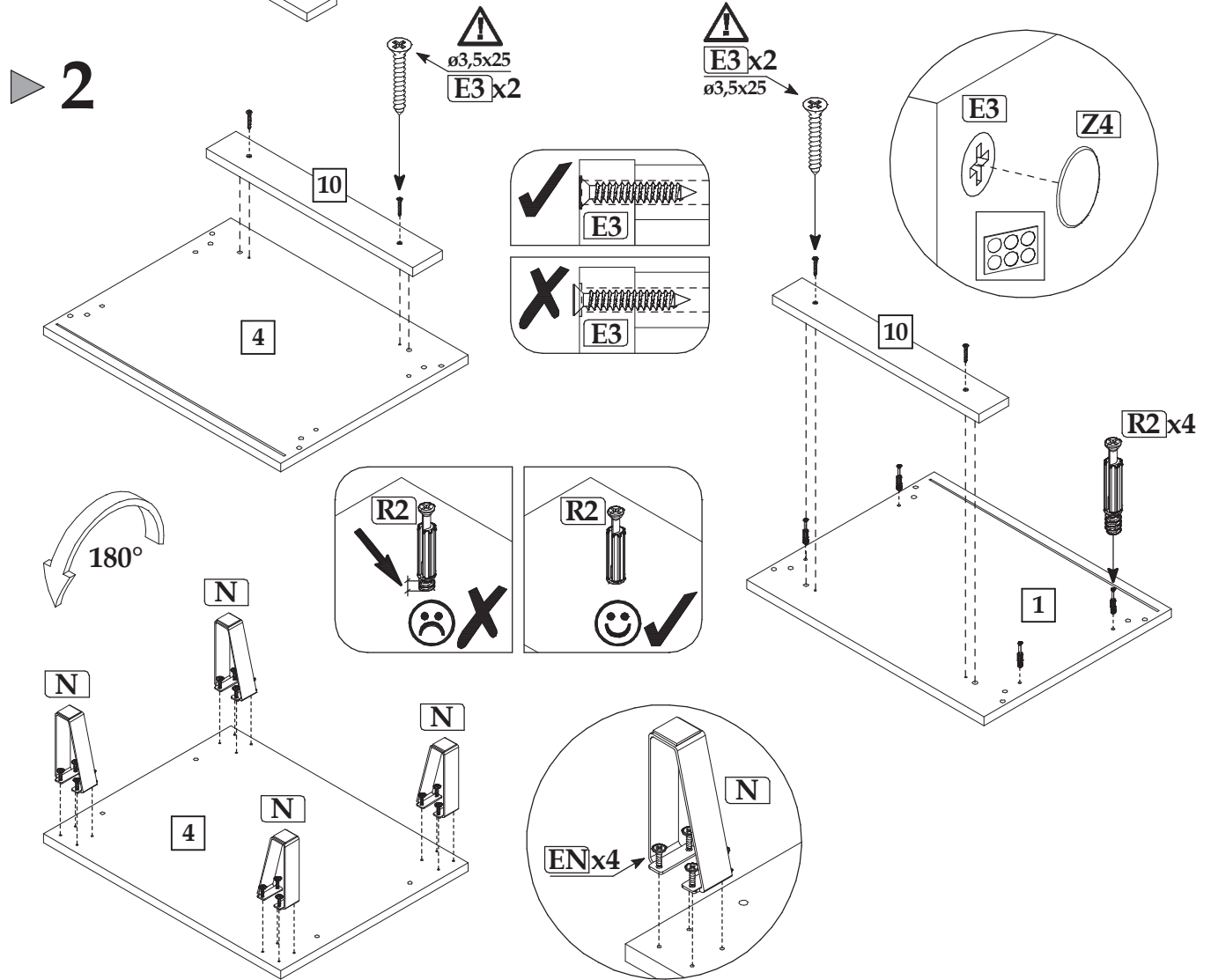
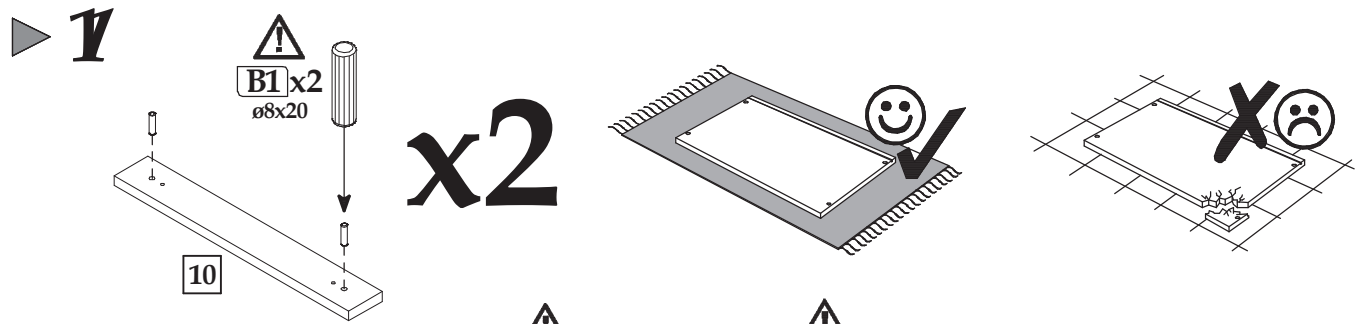

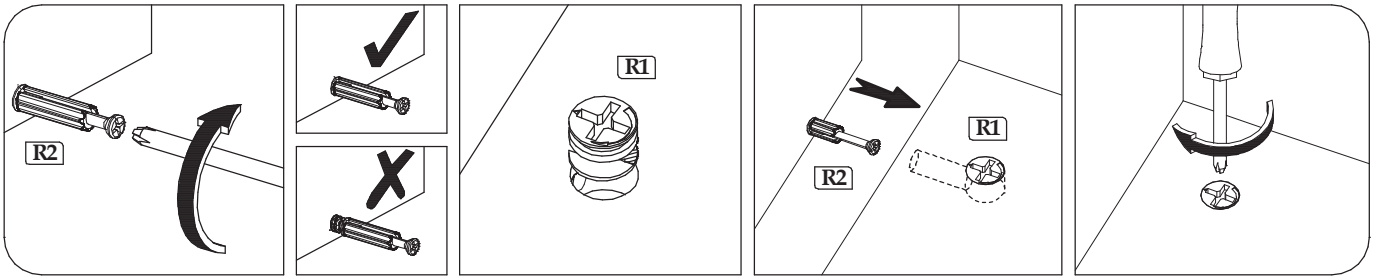

▶ 6

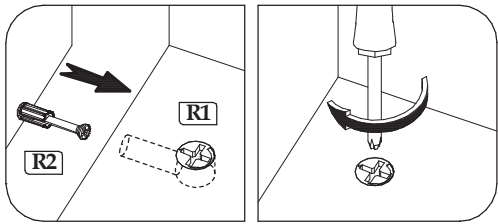
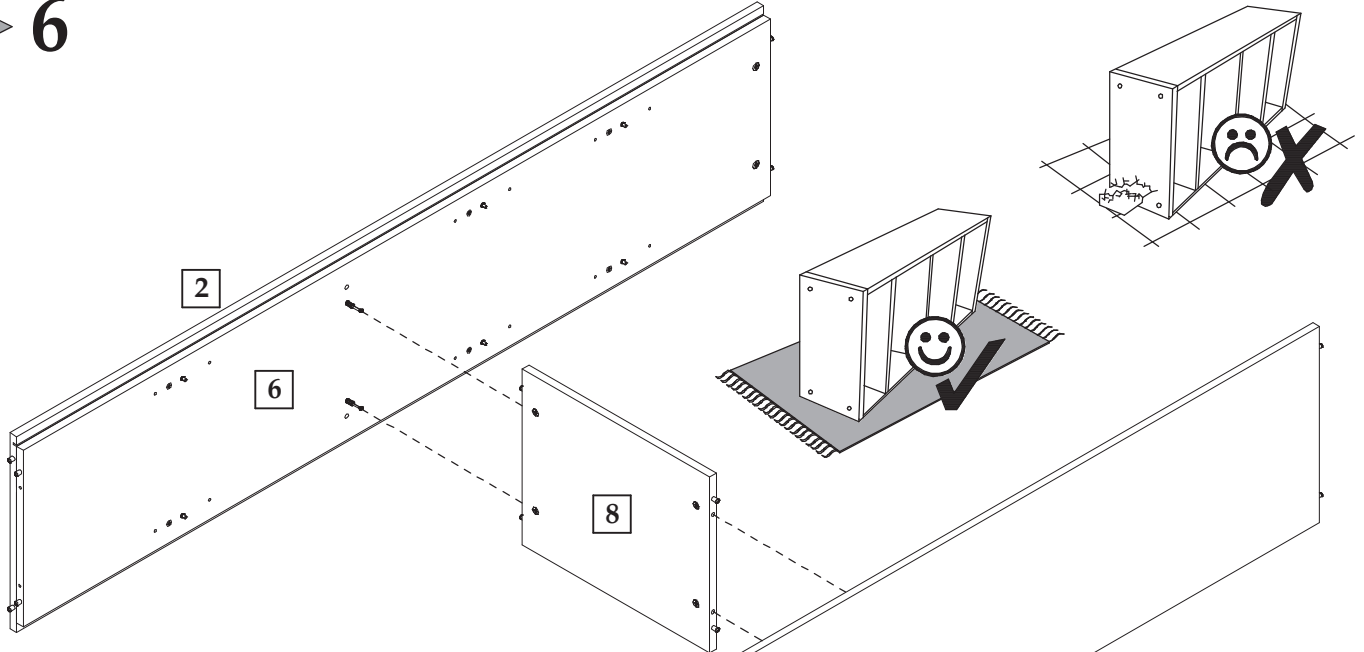

▶ 7

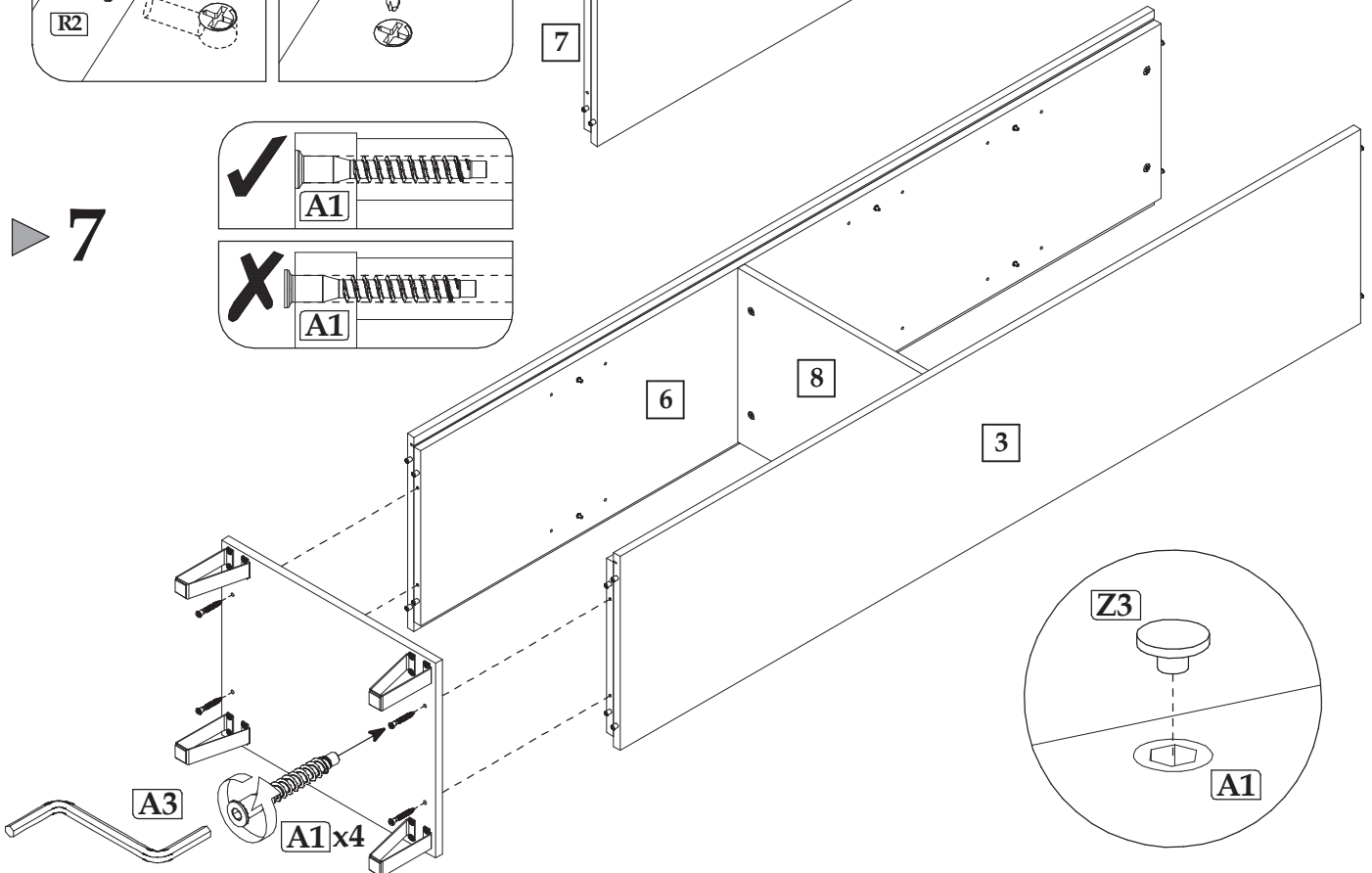
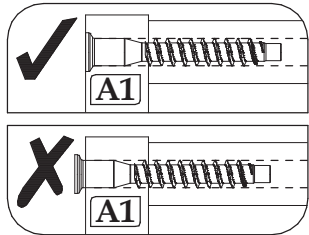

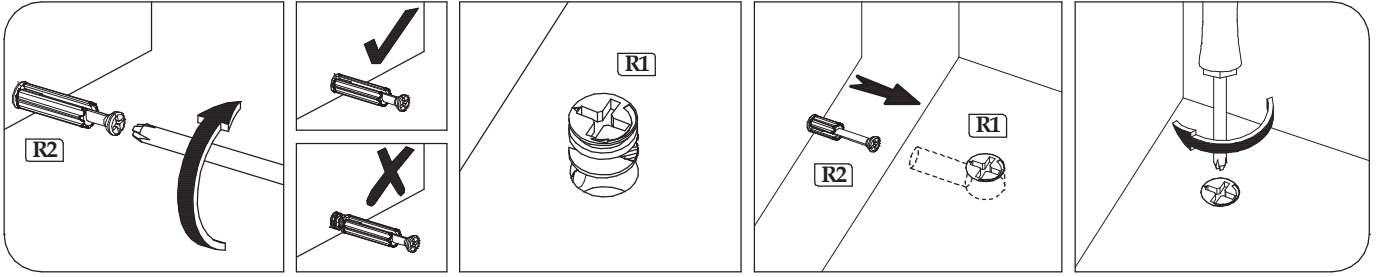

▶ 8

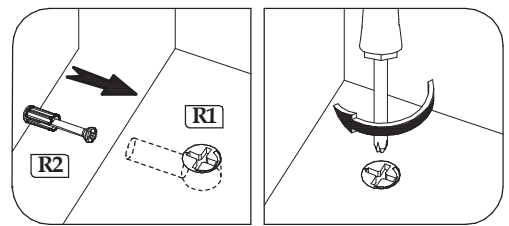
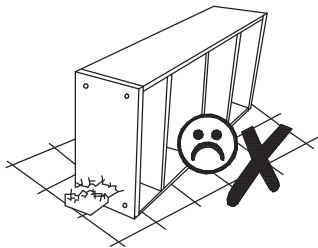
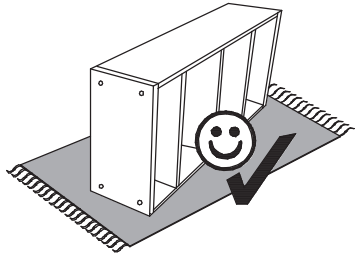
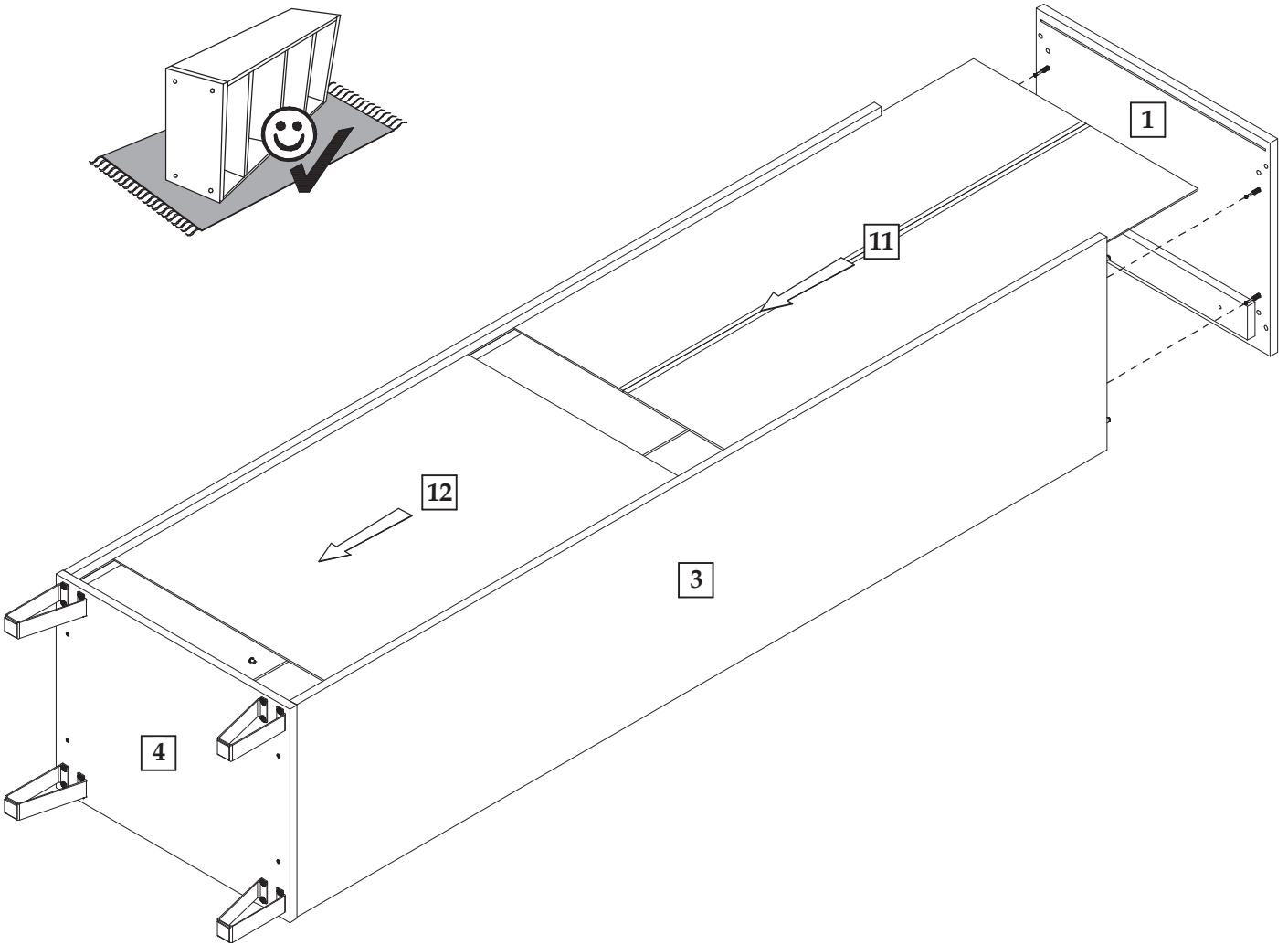

▶ 9

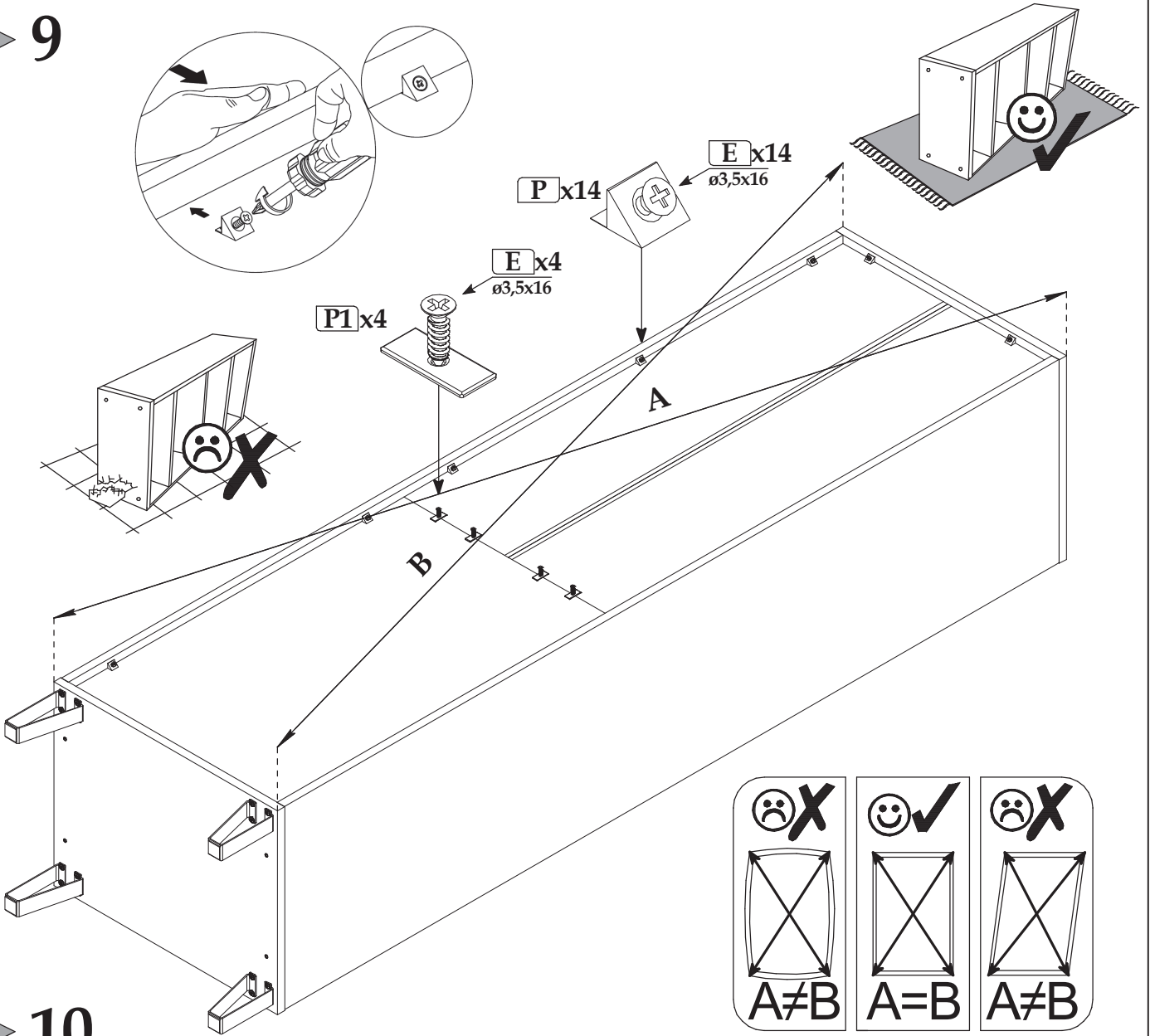

▶ 10

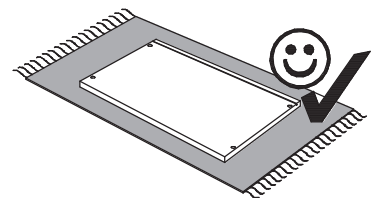
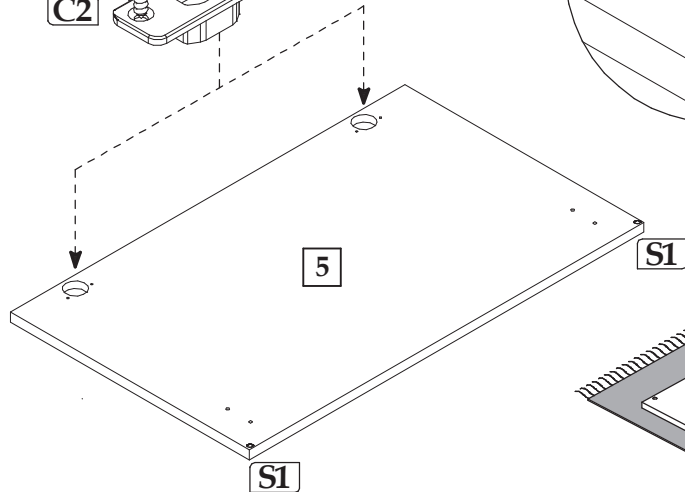
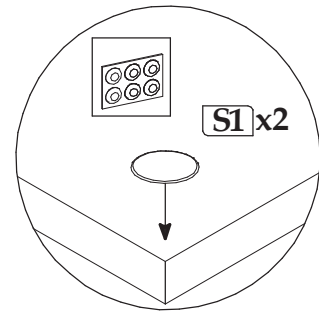
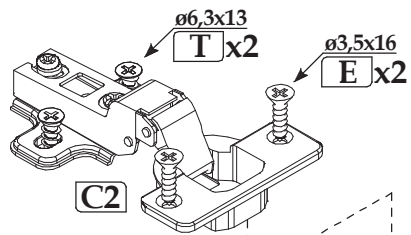
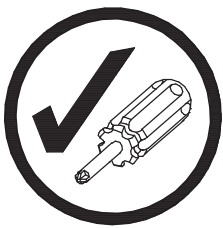

▶ 11

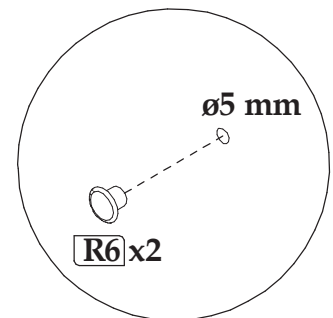
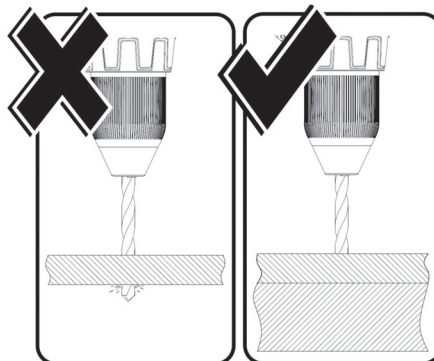
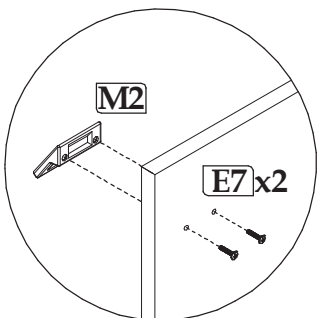
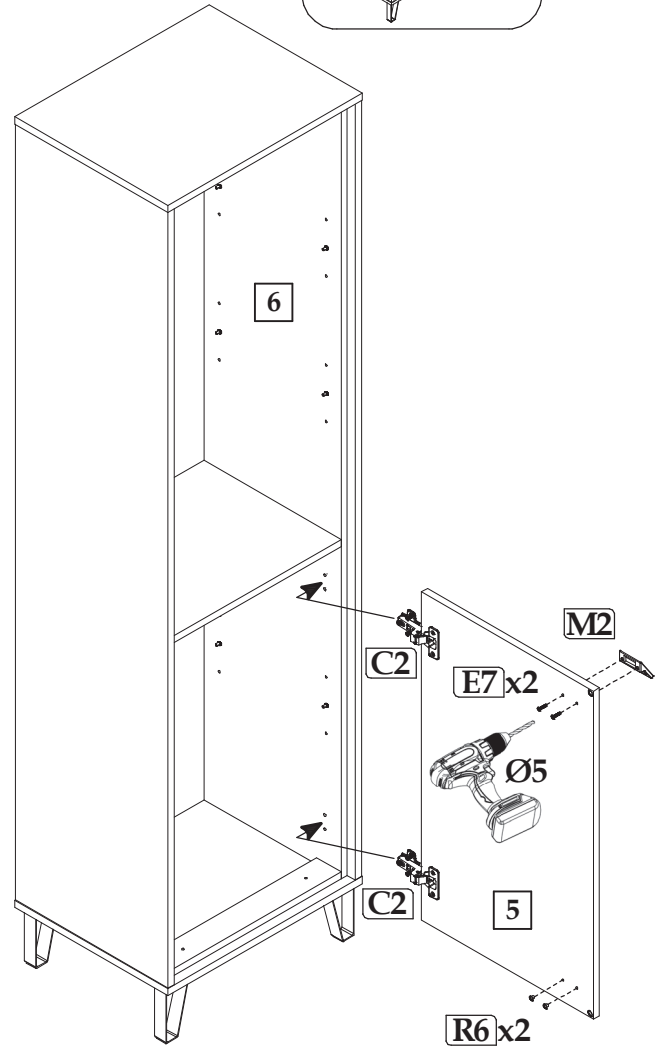
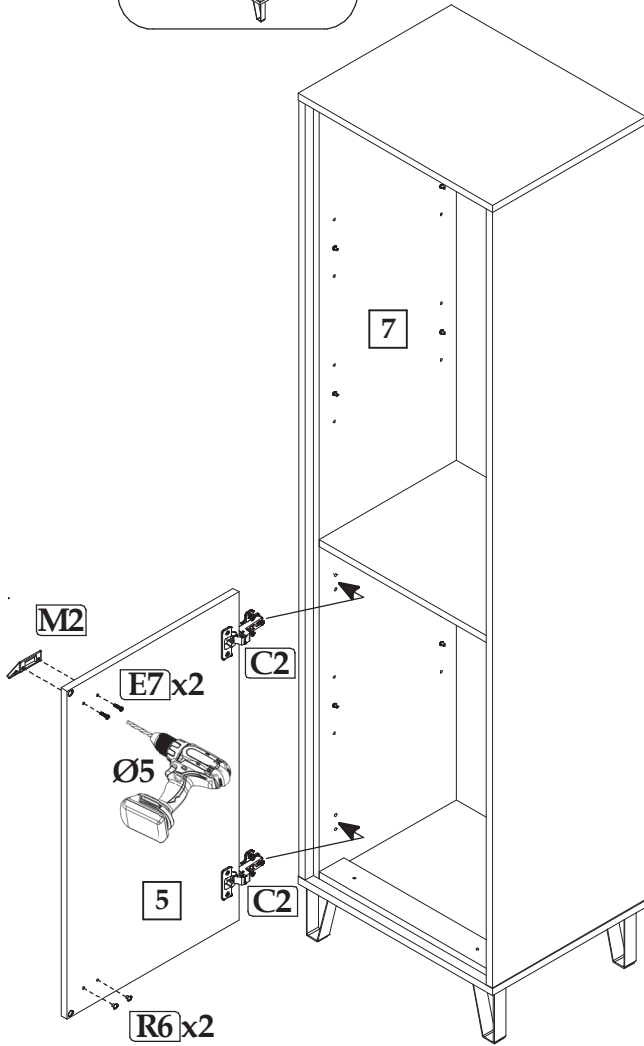
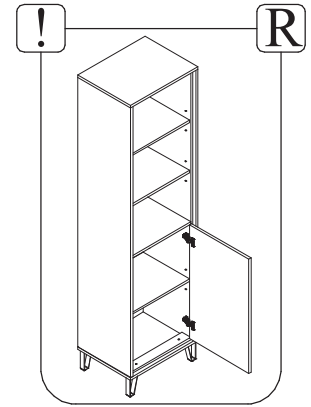
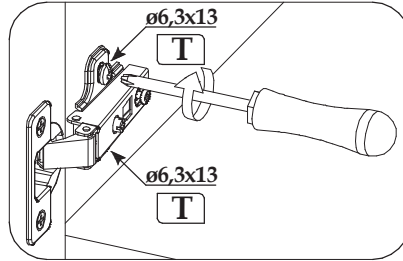
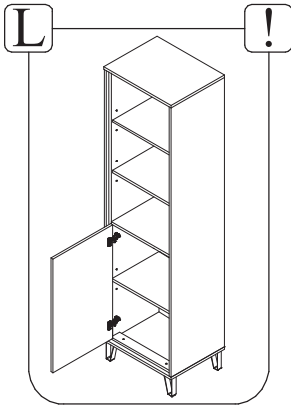

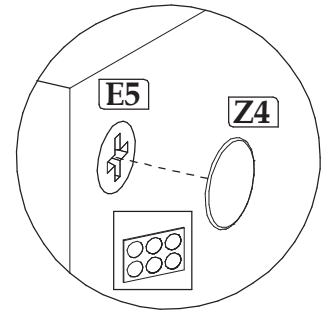
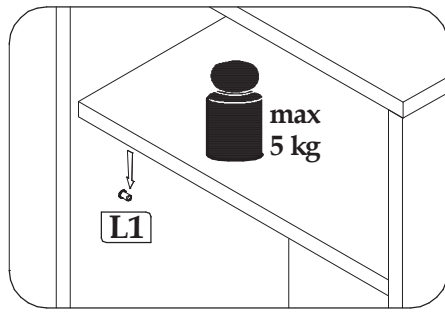
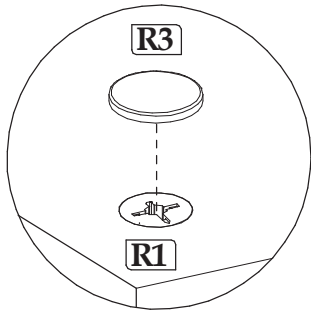

▶ 12

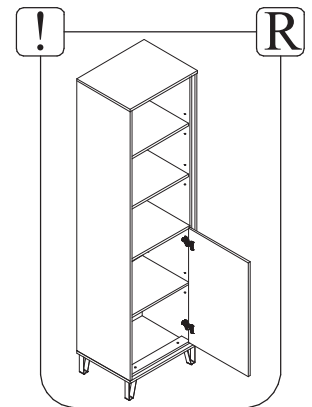
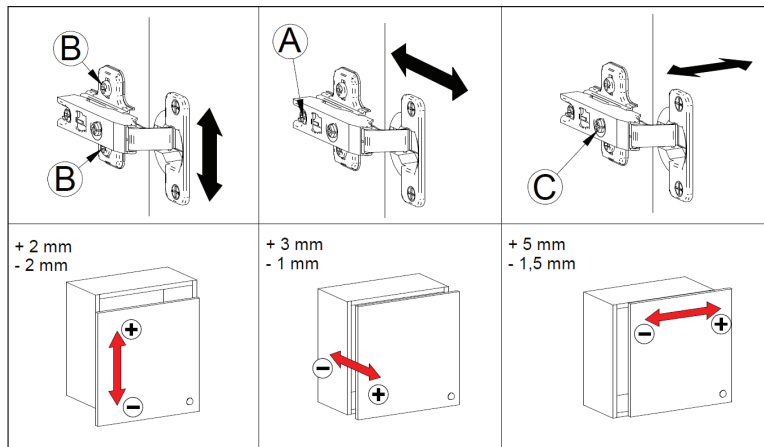
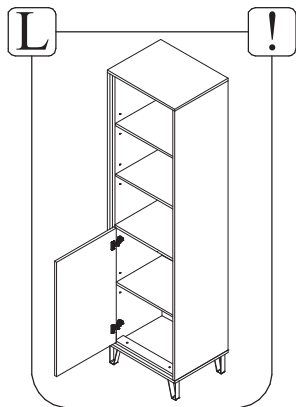
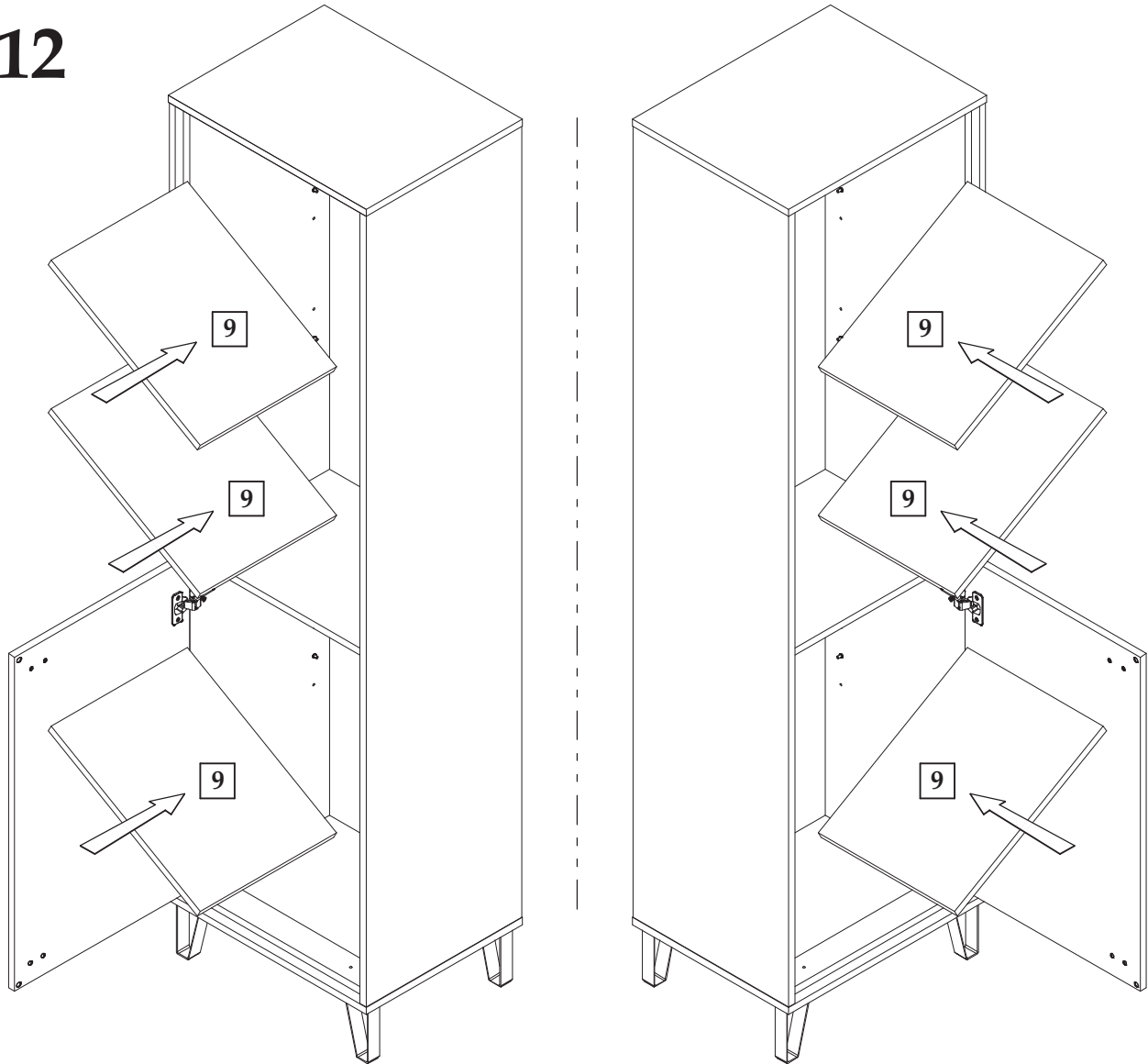

▶ 13

