

ML MEBLE Sp. z o.o.

Liw, ul. Zawadzka 14;

07-100 Węgrów; POLAND

www.mlmeble.pl, info@mlmeble.pl

PL - Instrukcja montażu / BG - Сглобяване инструкция / CZ - Montáž instrukce / DE - Montageanleitung / EN - Assembling instruction / ES - Montaje de instrucciones / EST - Paigaldusjuhend / FR - Notice de montage / HR - Sastavljanje upute / HU - Szerelési utasítás / I - Istruzioni di montaggio / LT - Montavimo instrukcija / LV - Montāžas instrukcija / NL - Montage instructie / P - Montagem de instruções / RO - Asamblarea de instrucțiuni / RU - Инструкция сборки / S - Monteringsinstruktion / SK - Montáž inštrukcie / SLO - Se-stavljanje navodila / SRB - Склапање инструкцију / TR - Kurulum Talimatları / UKR - Збірка інструкція /

**PL - Przed rozpoczęciem zapoznać się z instrukcją montażu** / BG - Преди да започнете се отнасят към инструкциите за инсталиране / CZ - Před zahájením naleznete v montážním návodu / DE - Vor die montage, bitte beiliegende anweisungen folgen / EN - Before starting, refer to the assembling advice in annex / ES - Antes de comenzar referirse a las instrucciones de instalación / EST - Enne käivitamist vaadake paigaldusjuhiseid / FR - Avant de commencer, se reporter aux conseils de montage en annexe / HR - Prije početka pogledajte upute za instalaciju / HU - Megkezdése előtt olvassa el a telepítési utasításokat / I - Avanti di cominciare, riportate agli consigli di montaggio / LT - Prieš pradedant kreiptis į montavimo instrukcija / LV - Pirms sākt montāžu, iepazīties ar instrukciju / NL - Voordat u begint zie de installatie-instructies / P - Antes de começar a consultar as instruções de instalação / RO - Înainte de a începe să consultați instrucțiunile de instalare / RU - Перед началом обратитесь к инструкции по установке / S - Innan du börjar se Installationsanvisningen / SK - Pred začatím nájdete v montážnom návode / SLO - Pred začetkom glejte navodila za namestitve / SRB - Пре почетка погледајте упутства за инсталацију / TR - Kurulum talimatnamesini sirasiyla takip edin. / UKR - Перед початком зверніться до інструкції з установки /

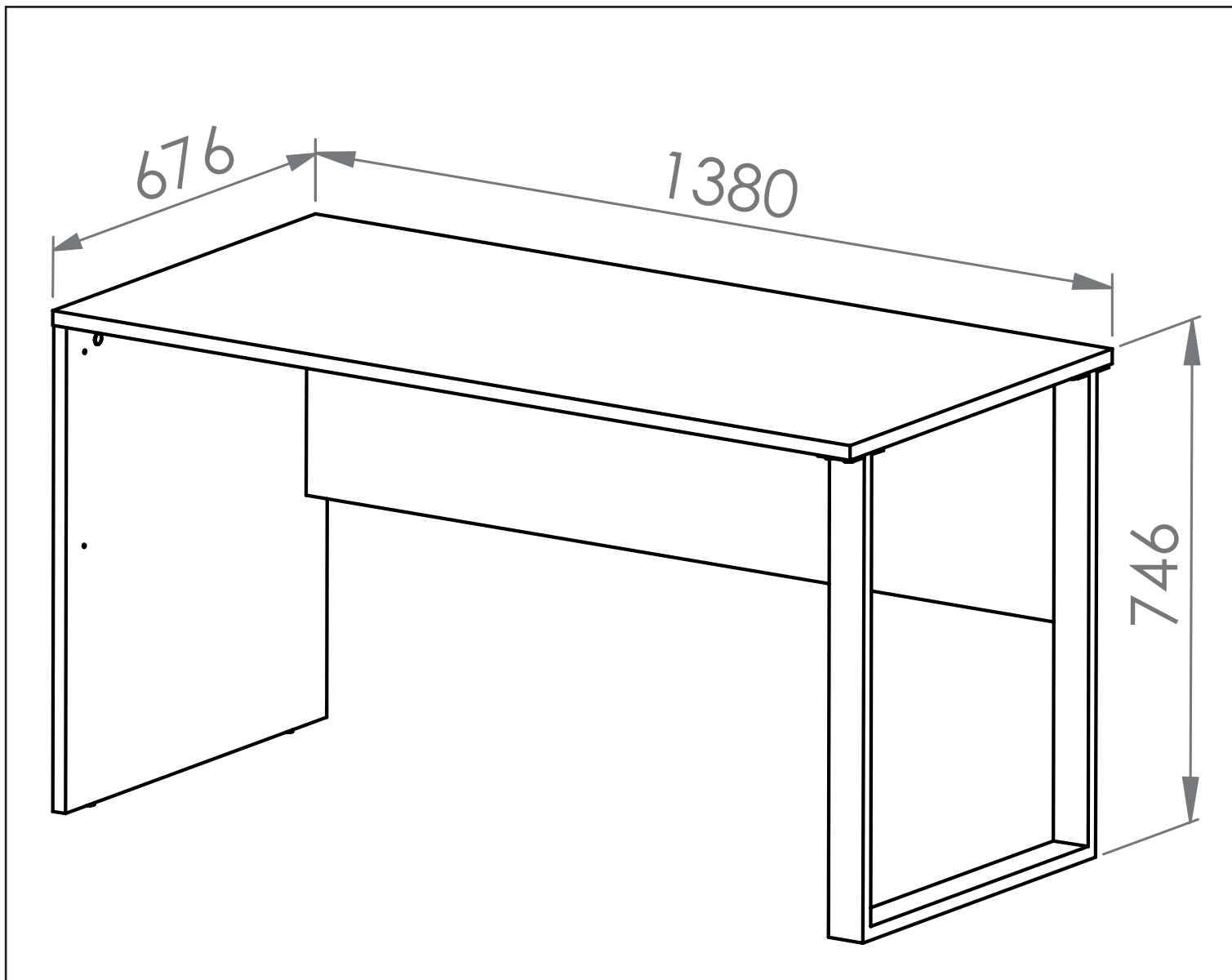
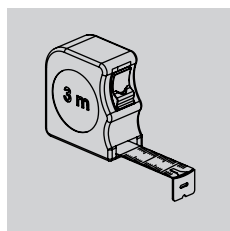
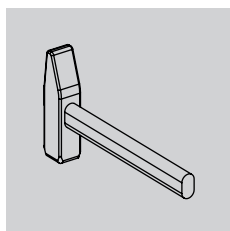
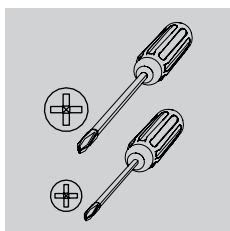
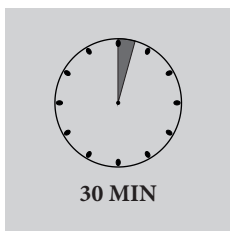
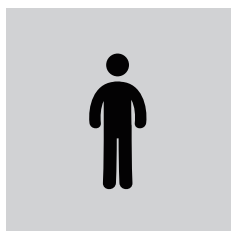

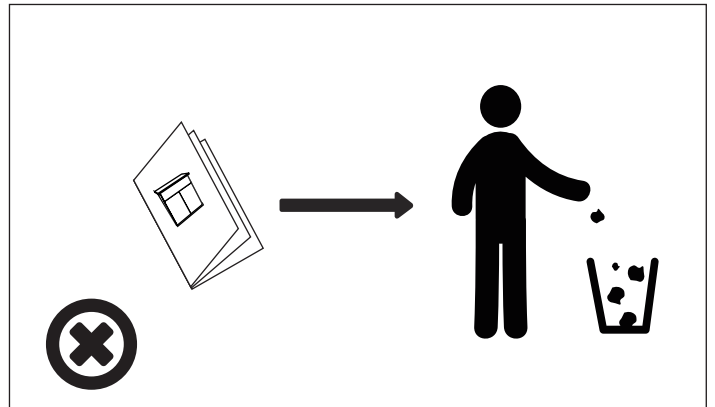
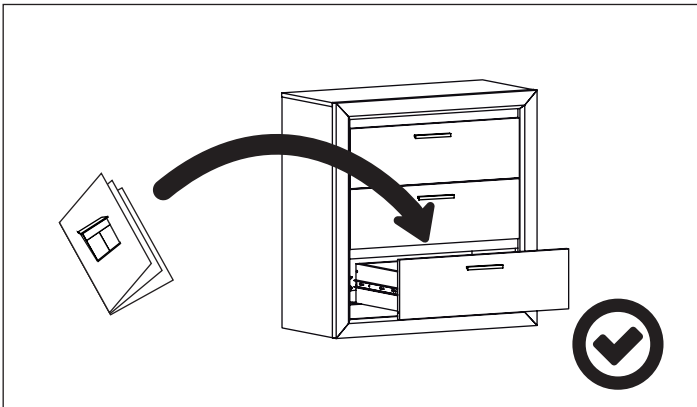
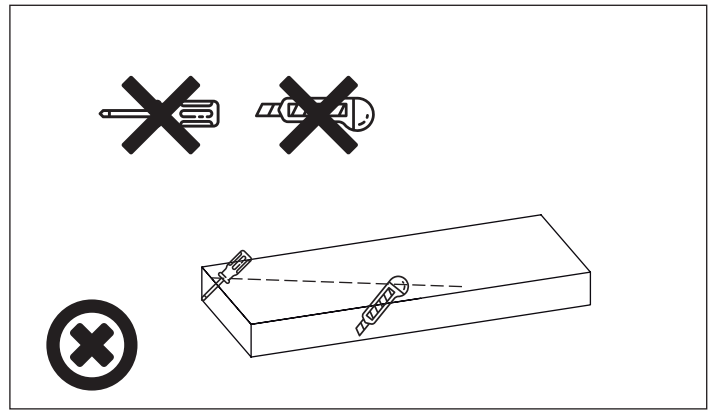
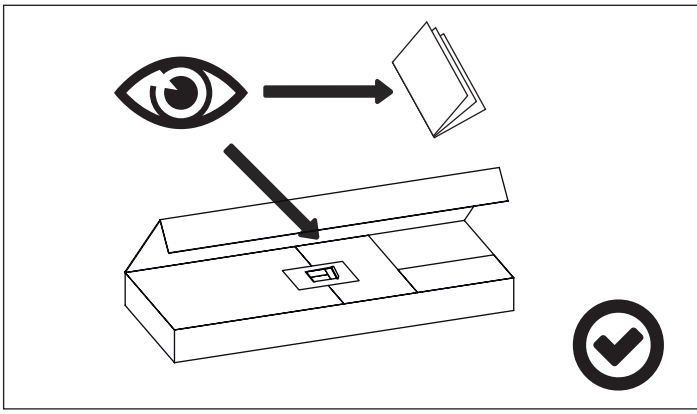



PL - Zachowaj w razie reklamacji !!! / BG - Пазете в случай на рекламация !!! / CZ - Uchovávejte pro případ stížnosti !!! / DE - Bewahren Sie das Etikett für Reklamationen !!! / ENG - Keep the label for complaints !!! / ES - Conservar en caso de reclamación !!! / EST - Kaebuse korral hoidke alles !!! / FR - Conserver en cas de réclamation !!! / HR - Zadržite u slučaju prigovora !!! / HU - Tartsa fenn panaszt esetén !!! / IT - Conservare in caso di reclamo !!! / LT - Laikykite skundo atveju !!! / LV - Saglabājiet sūdzības gadījumā !!! / NL - Bewaren in geval van een klacht !!! / PO - Guardar em caso de reclamação !!! / RO - Păstrați în cazul unei reclamații !!! / RU - Сохранить в случае рекламации !!! / S - Förvara vid klagomål !!! / SK - Majte v prípade reklamácie !!! / SLO - Hranite v primeru pritožbe !!! / SRB - Задржите у случају жалбе !!! / TR - Şikayet durumunda saklayın !!! / UKR - Зберігати у разі скарги !!!





Data produkciji:    Pakuļotājs  
Lot of production    Packager

0000-00-00 xxx/xxx/xxx



01000 0000 4000 0001

Nazwa wyrob. :XXXXX 00		☒	Brutto/gros		
Product name:			00.0	00	KG
Kolor:XXX XXXXX			☒		netto/net
Color: XXX XXXXX			000		KG
0XXXX00-000-0/0			☒		m <sup>3</sup>
			0		0.000

1/2

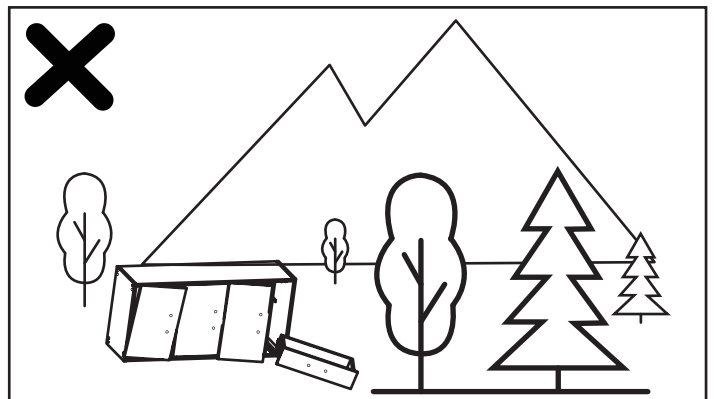
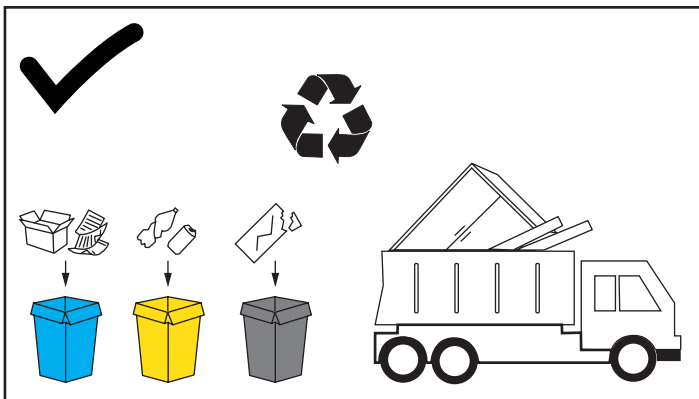
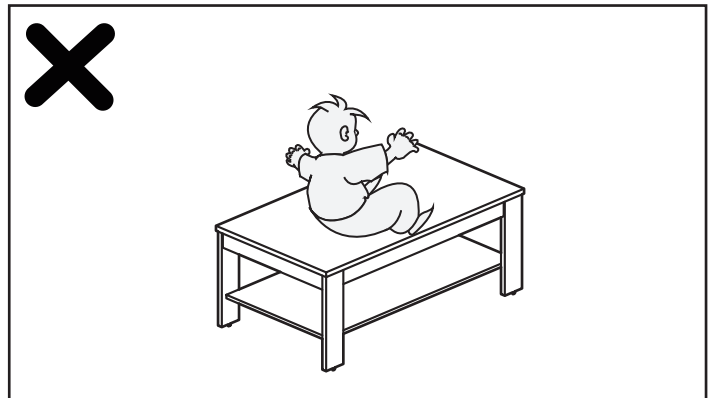
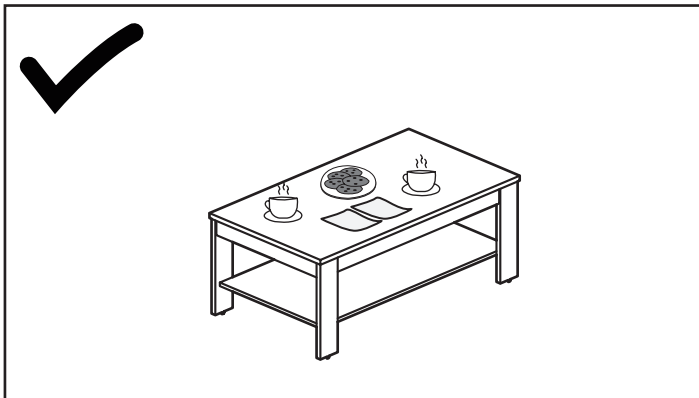
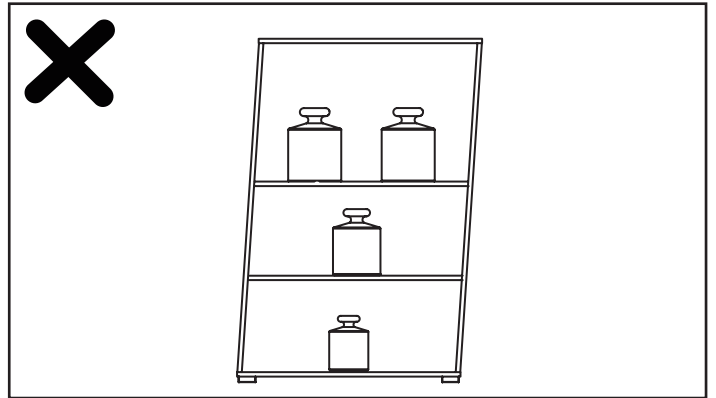
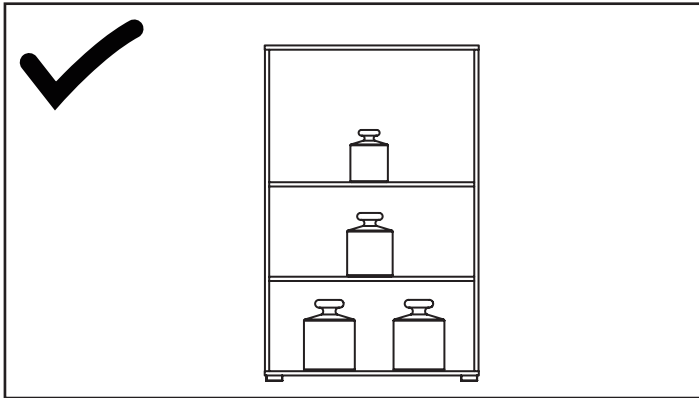
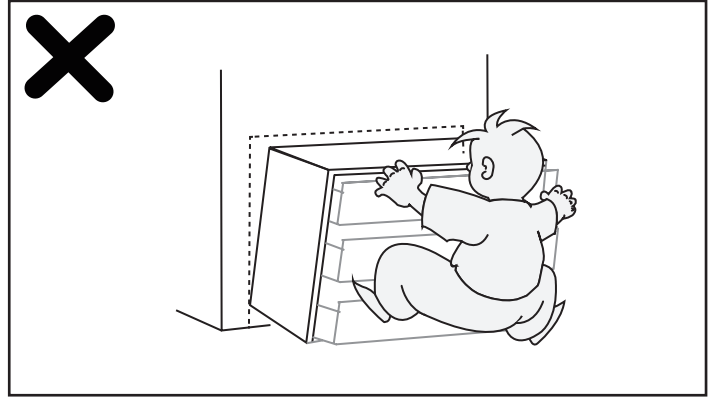
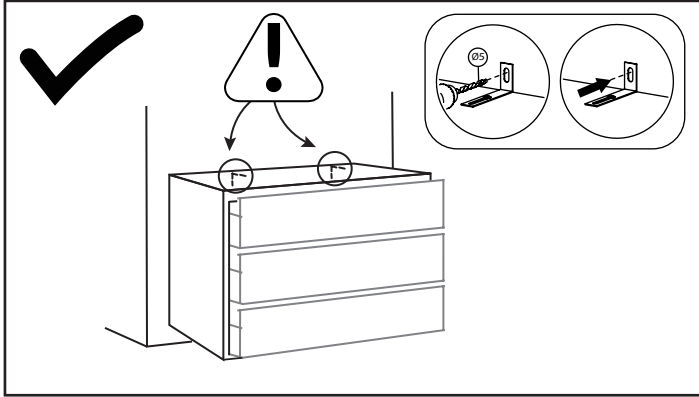

PL – Meble zawierające płyty drewnopochodne (np. płyta wiórowa, płyty z włókien) oraz elementy typu kleje używane podczas montażu, mogą emitować do powietrza nieznaczne ilości substancji używanych w procesach produkcyjnych lub samodzielnym montażu. Dlatego po zamontowaniu mebla zaleca się regularne wietrzenie pomieszczenia, w którym znajduje się mebel, do czasu wyeliminowania zapachu.

BG – Мебелите, съдържащи плоскости на дървесна основа (напр. плочи от дървесни частици, плочи от дървесни влакна), и компоненти като лепила, използвани при сглобяването, могат да отделят малки количества вещества във въздуха, които се използват в производствените процеси или при самостоятелното сглобяване. Поради това, след като мебелите са сглобени, е препоръчително редовно да се проветрява помещението, в което се намират мебелите, докато миризмата бъде премахната.

CZ – Nábytek obsahující desky na bázi dřeva (např. dřevotřískové desky, dřevovláknité desky) a komponenty, jako jsou lepidla používaná při montáži, mohou do ovzduší uvolňovat malá množství látek, které se používají při výrobních procesech nebo při vlastní montáži. Proto se po sestavení nábytku doporučuje pravidelně větrat místnost, ve které je nábytek umístěn, dokud se zápach neodstraní.

DE – Möbel, die Holzwerkstoffe (z. B. Spanplatten, Faserplatten) und Komponenten wie Klebstoffe enthalten, die bei der Montage verwendet werden, können geringe Mengen von Stoffen in die Luft abgeben, die bei der Herstellung oder Selbstmontage verwendet werden. Daher ist es ratsam, den Raum, in dem sich die Möbel befinden, nach der Montage regelmäßig zu lüften, bis der Geruch beseitigt ist.

EN – Furniture containing wood-based panels (e.g., particleboard, fiberboard) and elements such as adhesives used during assembly, may emit into the air insignificant amounts of substances used in manufacturing processes or self-assembly. Therefore, after assembling the furniture, it is recommended to regularly ventilate the room where the furniture is located until the smell is eliminated.

ES – Los muebles que contienen paneles a base de madera (por ejemplo, tableros de partículas, tableros de fibras) y componentes como los adhesivos utilizados durante el montaje, pueden emitir pequeñas cantidades de sustancias al aire, que se utilizan en los procesos de producción o en el automontaje. Por lo tanto, una vez montado el mueble, es aconsejable ventilar regularmente la habitación en la que se encuentra hasta que se haya eliminado el olor.

EST – Mööbel, mis sisaldavad puidupõhiseid plaate (nt puitlaastplaat, puitkiudplaat) ja komponendid, nagu kokkupanekul kasutatavad liimid, võivad eraldada õhku väikese koguse aineid, mida kasutatakse tootmisprotsessis või isekujundamisel. Seetõttu on soovitatav pärast mööbli kokkupanekut regulaarselt ventileerida ruumi, kus mööbel asub, kuni lõhn on kadunud.

FR – Les meubles contenant des panneaux à base de bois (p. ex. panneaux de particules, panneaux de fibres) et des composants tels que les adhésifs utilisés lors de l'assemblage peuvent émettre de petites quantités de substances dans l'air, qui sont utilisées dans les processus de production ou d'auto-assemblage. Par conséquent, une fois

le meuble monté, il est conseillé d'aérer régulièrement la pièce dans laquelle se trouve le meuble jusqu'à ce que l'odeur soit éliminée.

HR – Namještaj koji sadrži ploče na bazi drva (npr. iverica, vlaknaste ploče) i elemente poput ljepila koji se koriste tijekom sastavljanja mogu emitirati male količine tvari koje se koriste u proizvodnim procesima ili samosastavljanju u zrak. Stoga se nakon postavljanja namještaja preporuča redovito provjetravati prostoriju u kojoj se namještaj nalazi dok se neugodni mirisi ne uklone.

HU – A fa alapú lapokat (pl. forgácslapot, farostlemezt) tartalmazó bútorok és az olyan összetevők, mint az összeszerelés során használt ragasztók, kis mennyiségű anyagot juttathatnak a levegőbe, amelyeket a gyártási folyamatok vagy az önszerelés során használnak fel. Ezért a bútor összeszerelése után célszerű rendszeresen szellőztetni a helyiséget, amelyben a bútor található, amíg a szag megszűnik

ITA – I mobili contenenti pannelli a base di legno (ad es. pannelli di particelle, pannelli di fibra) e componenti come gli adesivi utilizzati durante l'assemblaggio, possono emettere nell'aria piccole quantità di sostanze utilizzate nei processi di produzione o di auto-assemblaggio. Pertanto, una volta assemblati i mobili, si consiglia di ventilare regolarmente la stanza in cui si trovano i mobili fino all'eliminazione dell'odore

LV – Mēbeles, kuru sastāvā ir koksnes paneļi (plemēram, skaidu plātnes, kokskaidu plātnes, kokšķiedru plātnes) un sastāvdaļas, piemēram, montāžas laikā izmantotās līmes, var emitēt gaisā nelielu daudzumu vielu, kas tiek izmantotas ražošanas vai pašmontāžas procesos. Tāpēc pēc mēbeļu montāžas ieteicams regulāri vēdināt telpu, kurā atrodas mēbeles, līdz smaka ir novērsta.

LT – Baldai, kurių sudėtyje yra medienos plokščių (pvz., medienos drožlių plokštės, plaušų plokštės) ir sudedamųjų dalių, pavyzdžiui, klijų, naudojamų surinkimo metu, į orą gali išsiskirti nedideli kiekiai medžiagų, naudojamų gamybos procesuose arba savęs surinkimo metu. Todėl surinkus baldus patartina reguliariai vėdinti patalpą, kurioje yra baldai, kol kvapas bus pašalintas.

NL – Meubels die platen op houtbasis bevatten (bv. spaanplaat, vezelplaat) en componenten zoals lijmen die tijdens de assemblage worden gebruikt, kunnen kleine hoeveelheden stoffen in de lucht afgeven die worden gebruikt tijdens productieprocessen of zelfmontage. Daarom is het raadzaam om de ruimte waarin de meubels staan na montage regelmatig te ventileren totdat de geur is verdwenen

PT – Os móveis que contêm painéis à base de madeira (por exemplo, painéis de partículas, painéis de fibras) e componentes como as colas utilizadas durante a montagem podem emitir pequenas quantidades de substâncias para o ar, que são utilizadas nos processos de produção ou de auto-montagem. Por conseguinte, após a montagem dos móveis, é aconselhável ventilar regularmente a divisão onde se encontram os móveis até que o cheiro seja eliminado.

RO – Mobila care conține panouri pe bază de lemn (de exemplu, plăci aglomerate, plăci din fibre) și componente precum adezivii utilizați în timpul asamblării pot emite în aer cantități mici de substanțe care sunt utilizate în procesele de producție sau autoasamblare. Prin urmare, odată ce mobila a

fost asamblată, este recomandabil să se ventileze în mod regulat încăperea în care se află mobila până la eliminarea mirosului.

RU – Мебель, содержащая древесные плиты (например, ДСП, ДВП) и такие компоненты, как клей, используемый при сборке, может выделять в воздух небольшое количество веществ, которые используются в процессе производства или самостоятельной сборки. Поэтому после сборки мебели рекомендуется регулярно проветривать помещение, в котором она находится, до устранения запаха.

SE – Möbler som innehåller träbaserade skivor (t.ex. spånskivor, fiberskivor) och komponenter som lim som används vid montering kan avge små mängder ämnen till luften som används i produktionsprocesser eller vid självmontering. När möblerna har monterats är det därför lämpligt att regelbundet ventilerat det rum där möblerna finns tills lukten har försvunnit.





SK – Nábytok obsahujúci dosky na báze dreva (napr. drevotrieskové dosky, drevovláknité dosky) a komponenty, ako sú lepidlá používané pri montáži, môžu do ovzdušia emitovať malé množstvá látok, ktoré sa používajú vo výrobných procesoch alebo pri vlastnej montáži. Preto sa po zmontovaní nábytku odporúča pravidelne vetrať miestnosť, v ktorej sa nábytok nachádza, až do odstránenia zápachu.





SLO – Pohištvo, ki vsebuje plošče na osnovi lesa (npr. iverne plošče, vlaknene plošče), in komponente, kot so lepila, ki se uporabljajo pri sestavljanju, lahko v zrak oddajajo majhne količine snovi, ki se uporabljajo v proizvodnih postopkih ali pri samosestavljanju. Zato je po sestavljanju pohištva priporočljivo redno prezračevati prostor, v katerem je pohištvo, dokler se vonj ne odpravi.

SRB – Namешtaj koji sadrži ploče na bazi drveta (npr. iverice, ploče od vlakana) i elemente kao što su lepкови koji se koriste tokom montaže mogu emitovati male količine supstanci koje se koriste u proizvodnim procesima ili samomontaži u vazduh. Zbog toga se nakon ugradnje namешtaja preporučuje redovno provetravaње prostorije u kojoj se nalazi namешtaj dok se miris ne eliminiše.

TR – Ahşap bazlı paneller (örn. yonga levha, lif levha) ve montaj sırasında kullanılan yapıştırıcılar gibi bileşenler içeren mobilyalar, üretim süreçlerinde veya kendi kendine montajda kullanılan az miktarda maddeyi havaya yayabilir. Bu nedenle, mobilya monte edildikten sonra, koku giderilene kadar mobilyanın bulunduğu odanın düzenli olarak havalandırılması tavsiye edilir.

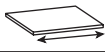
UKR – Меблі, що містять панелі на основі деревини (наприклад, ДСП, ДВП) і компоненти, такі як клеї, що використовуються під час складання, можуть виділяти в повітря невелику кількість речовин, які використовуються в процесі виробництва або самостійного складання. Тому після того, як меблі будуть зібрані, рекомендується регулярно провітрювати приміщення, в якому вони знаходяться, поки запах не зникне.

	CODE					
1	Bardo12_03	1296	380	16	1	1/1
2	4NOGA-BARD-CZAR.MAT	724	600	20	1	1/1
3	Bardo12_02	721	600	22	1	1/1
4	Bardo12_01	1380	676	22	1	1/1
5						
6						
7						
8						
9						
10						
11						
12						
13						
14						
15						

	CODE					
16						
17						
18						
19						
20						
21						
22						
23						
24						
25						
26						
27						
28						
29						
30						

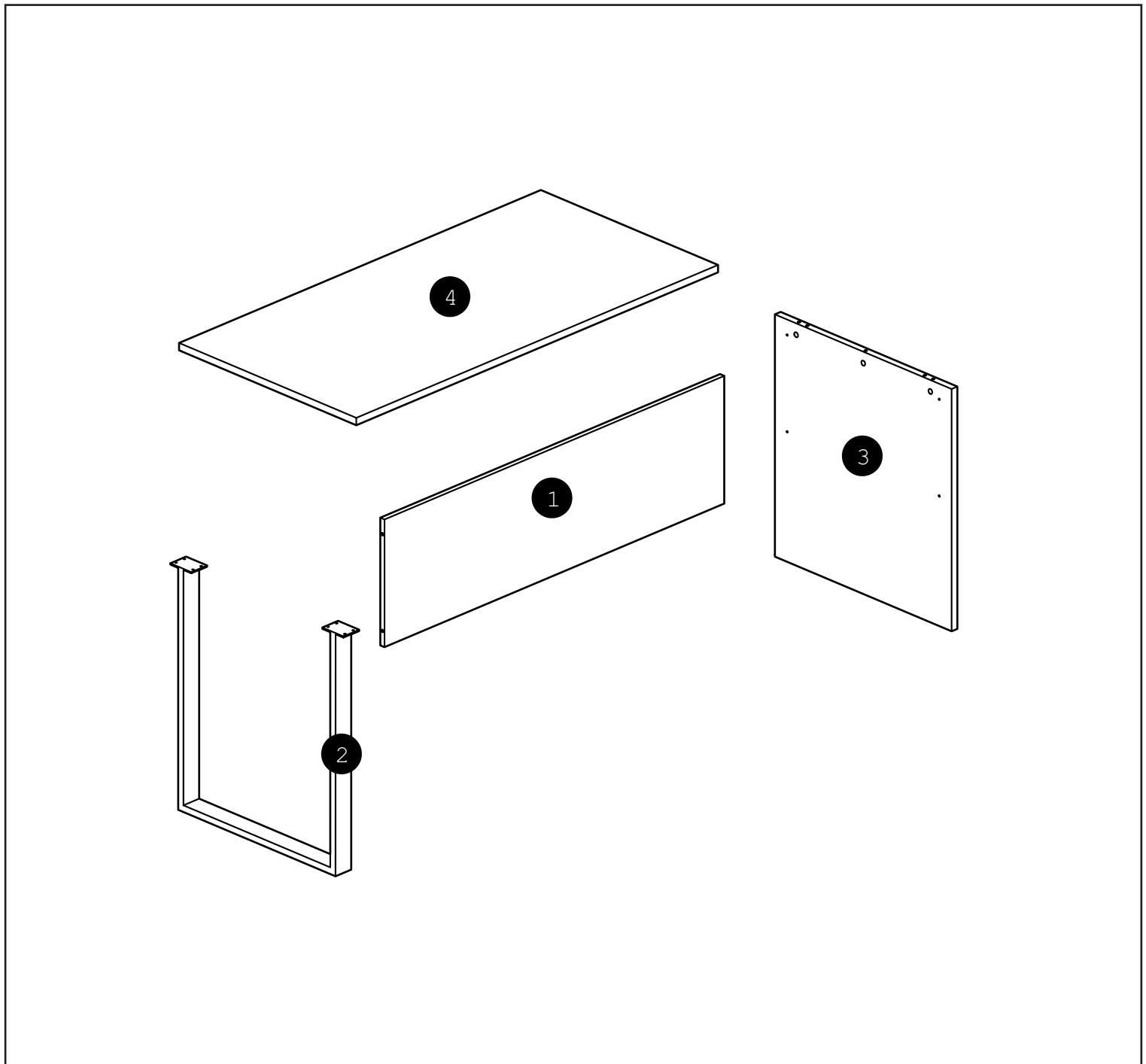

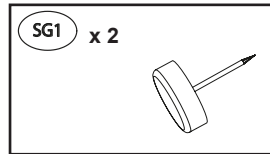
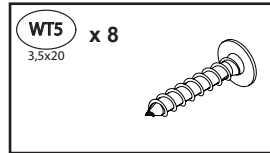
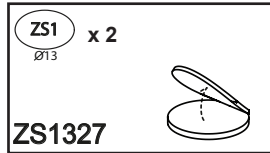
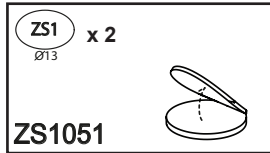
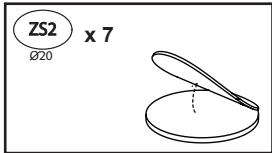
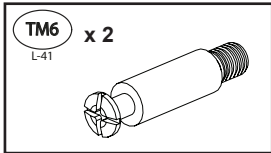
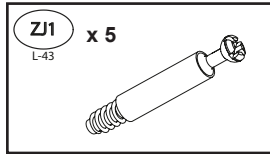
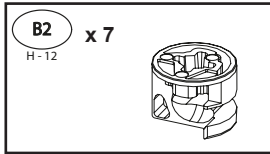
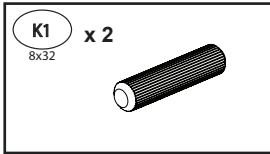
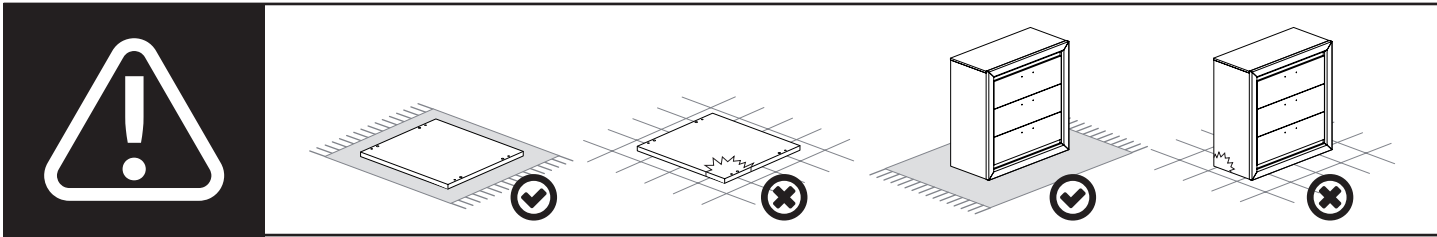

1

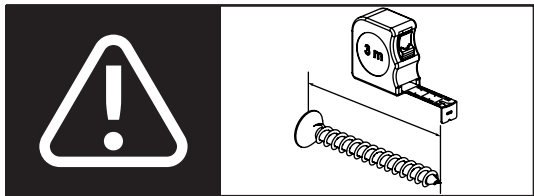
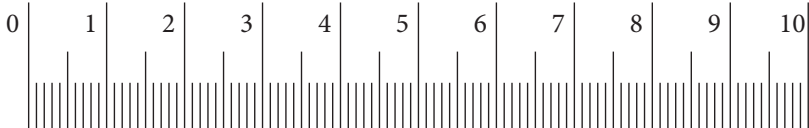
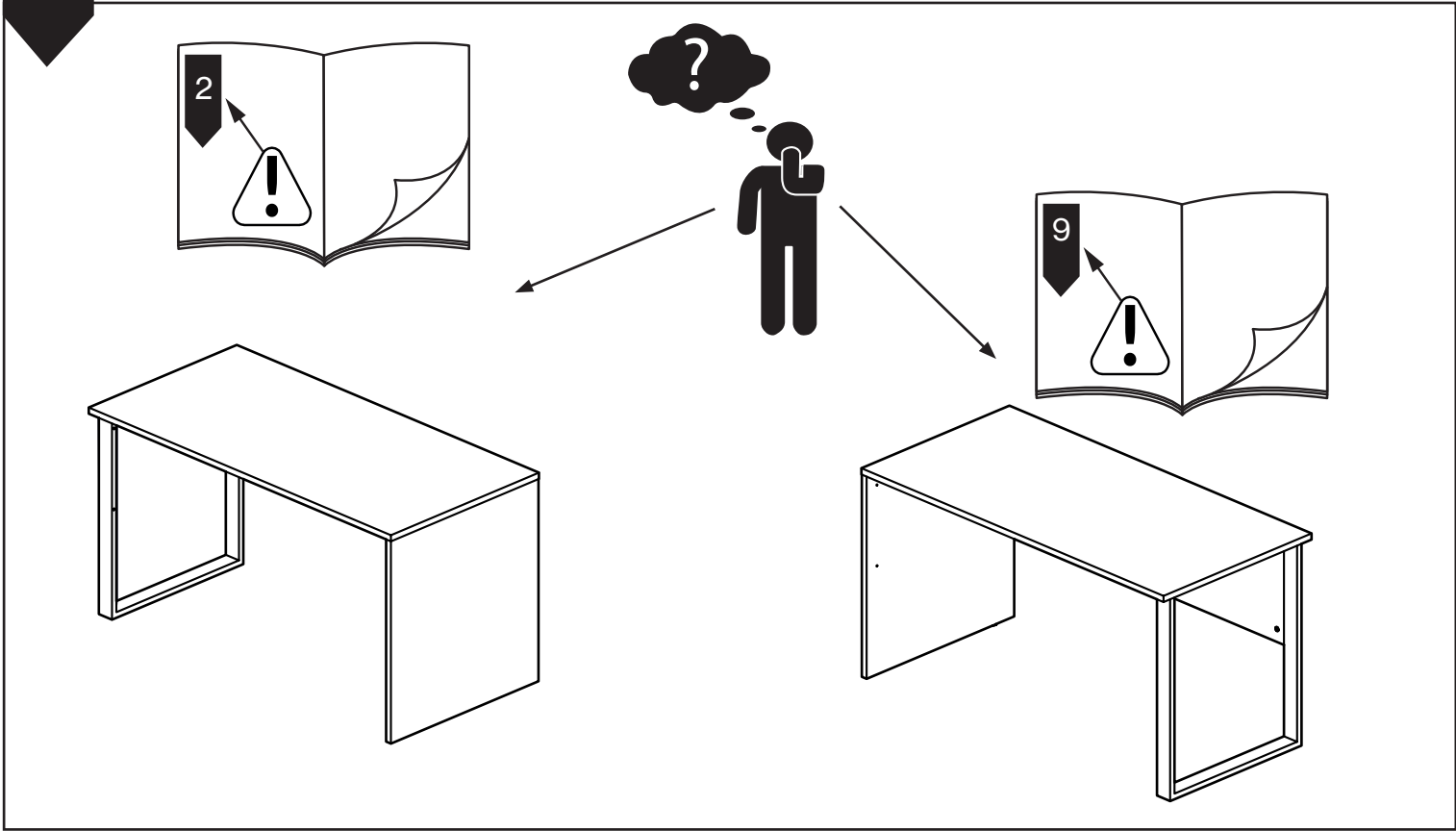

2

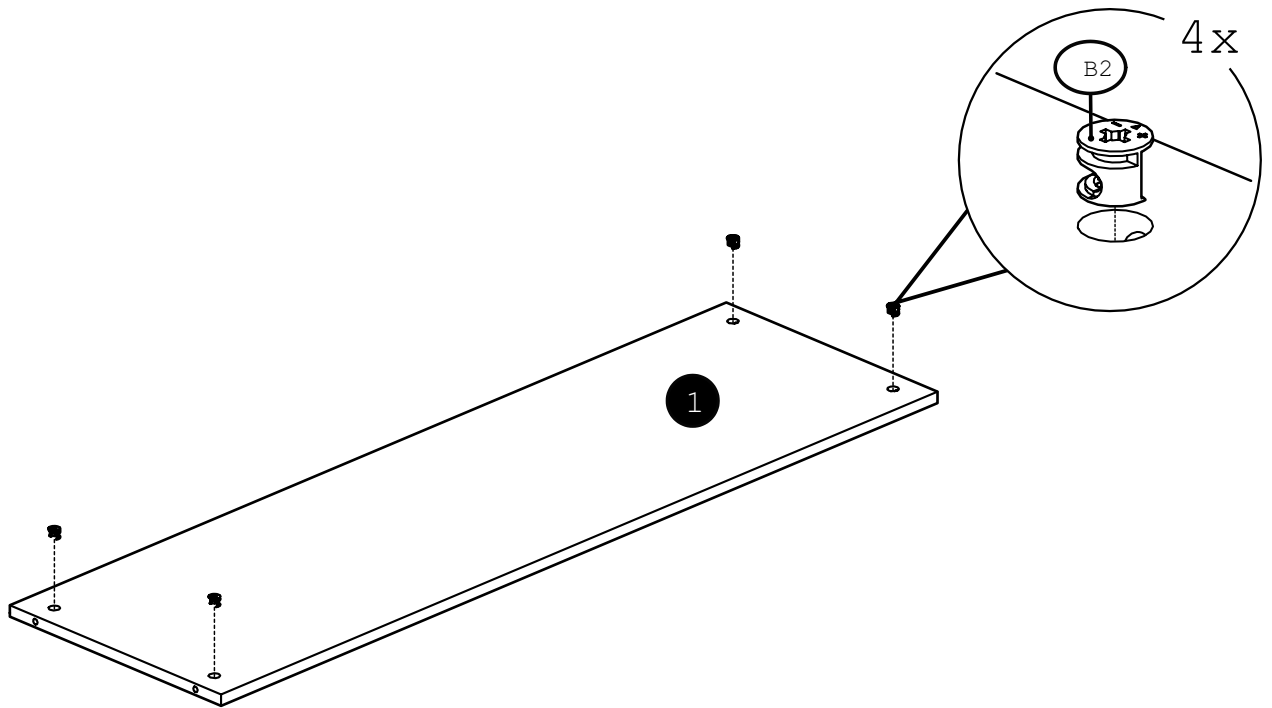
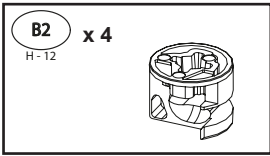

3

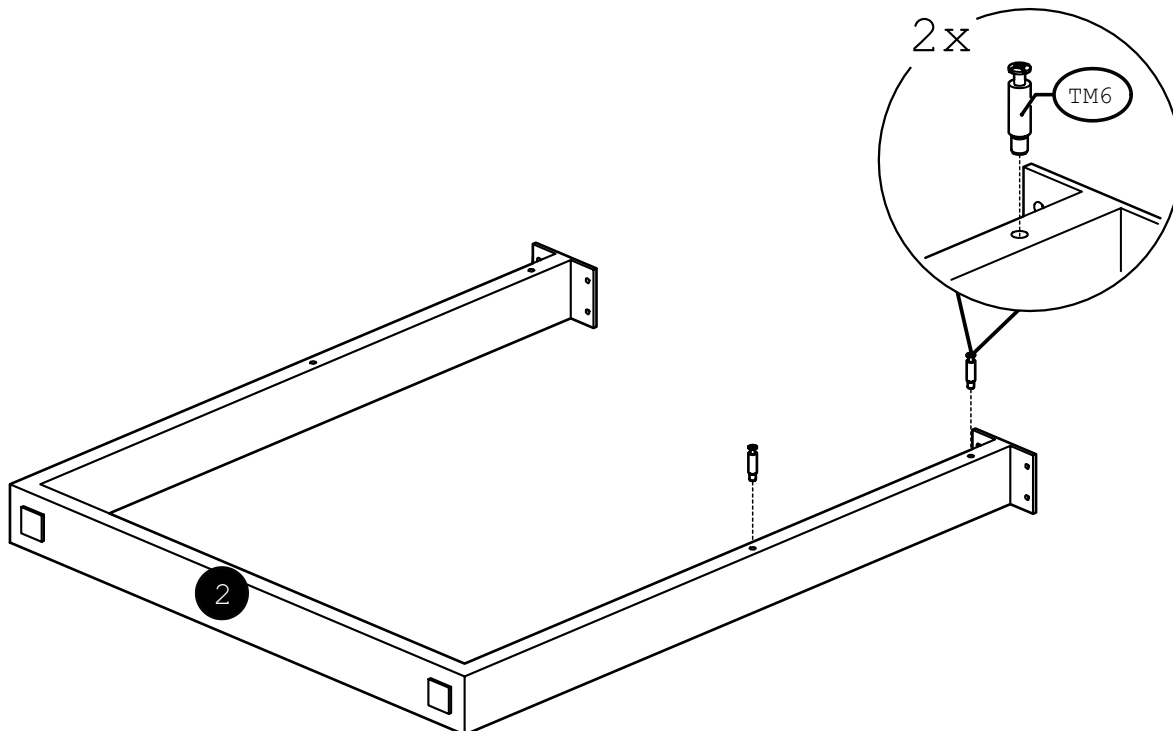
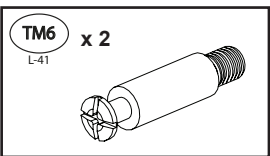

4

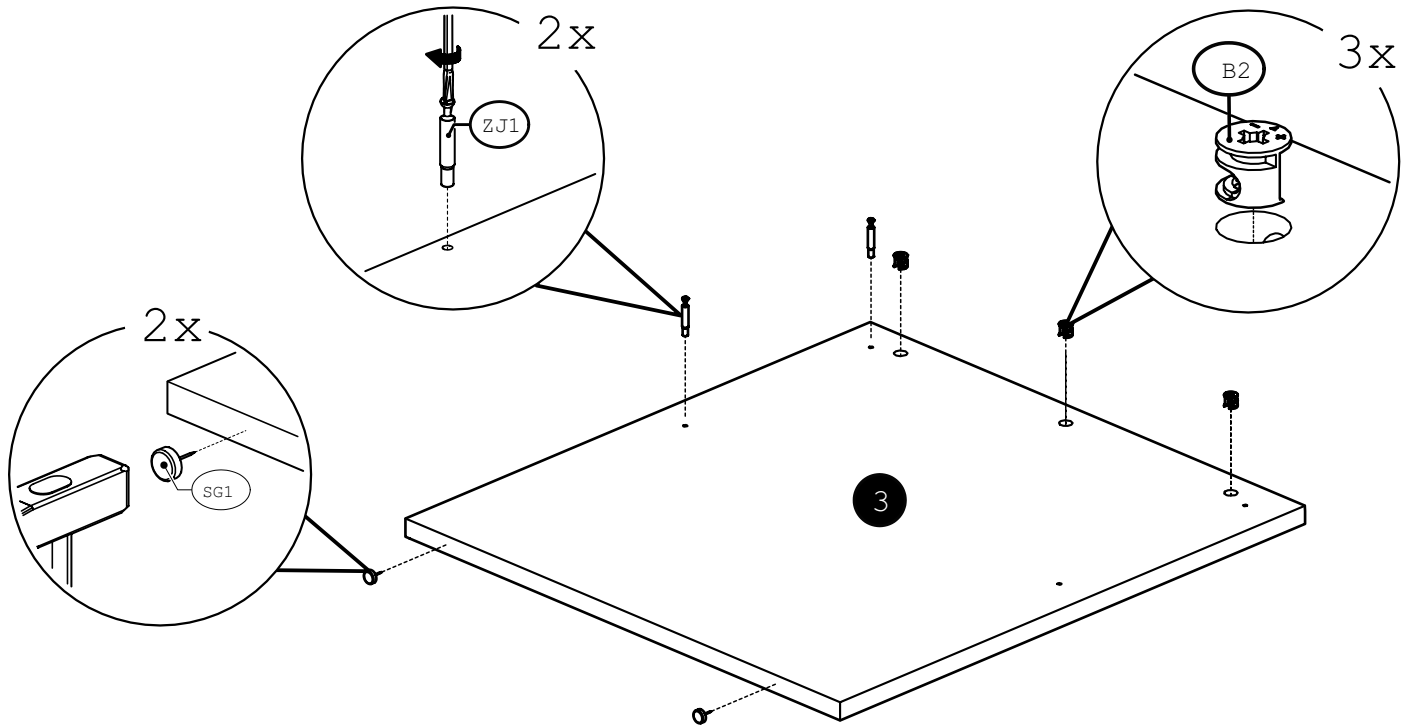
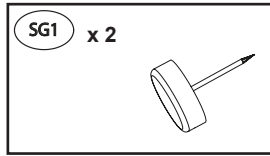
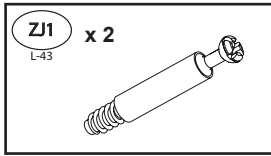
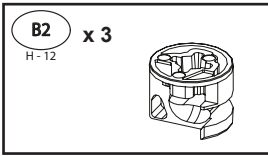

5

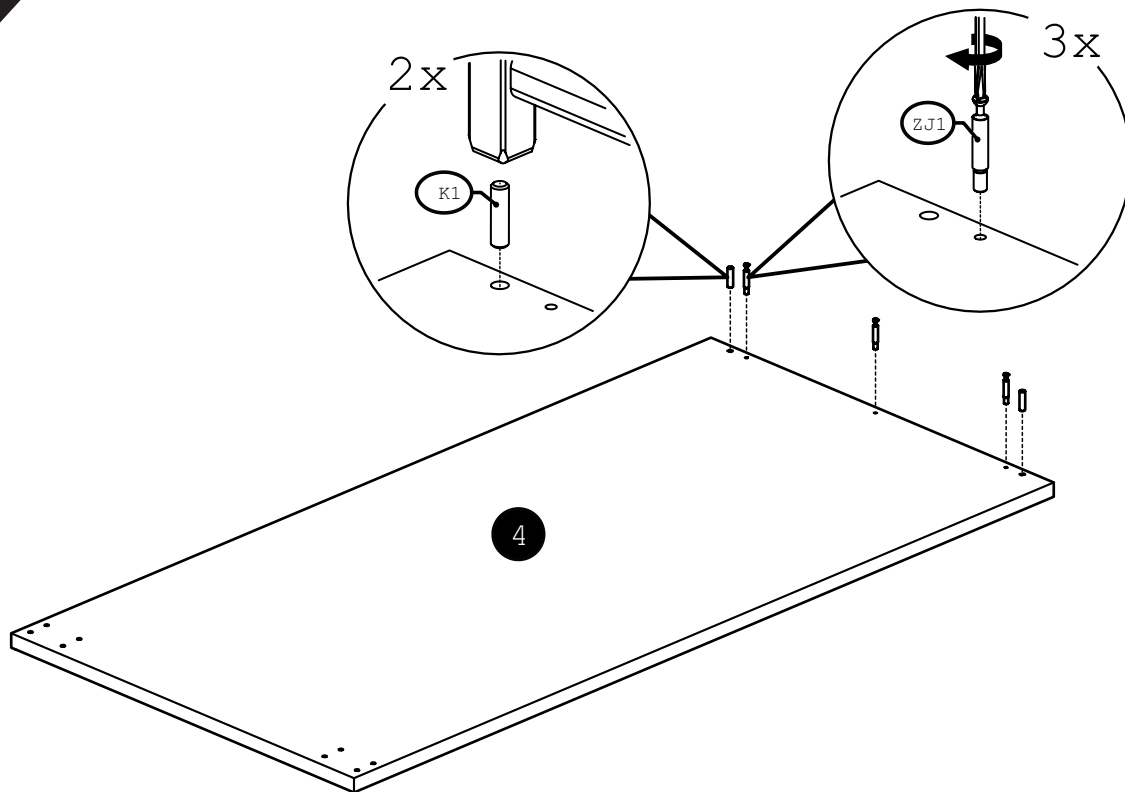
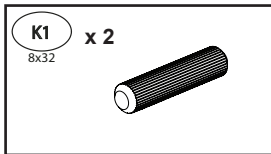
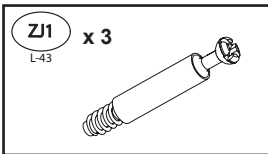



6

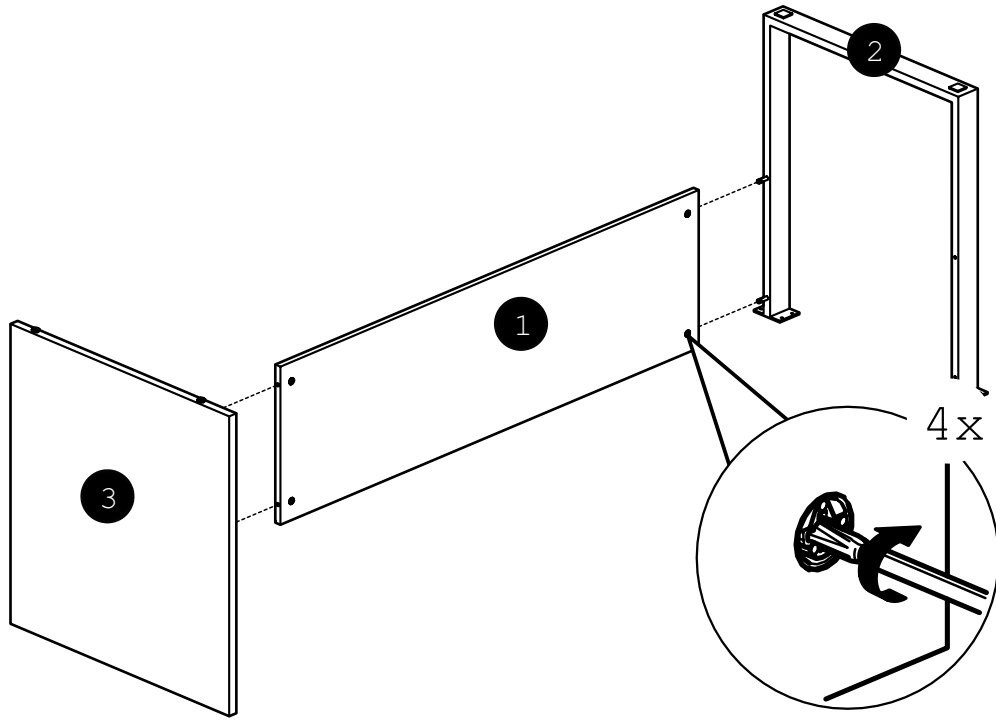

7

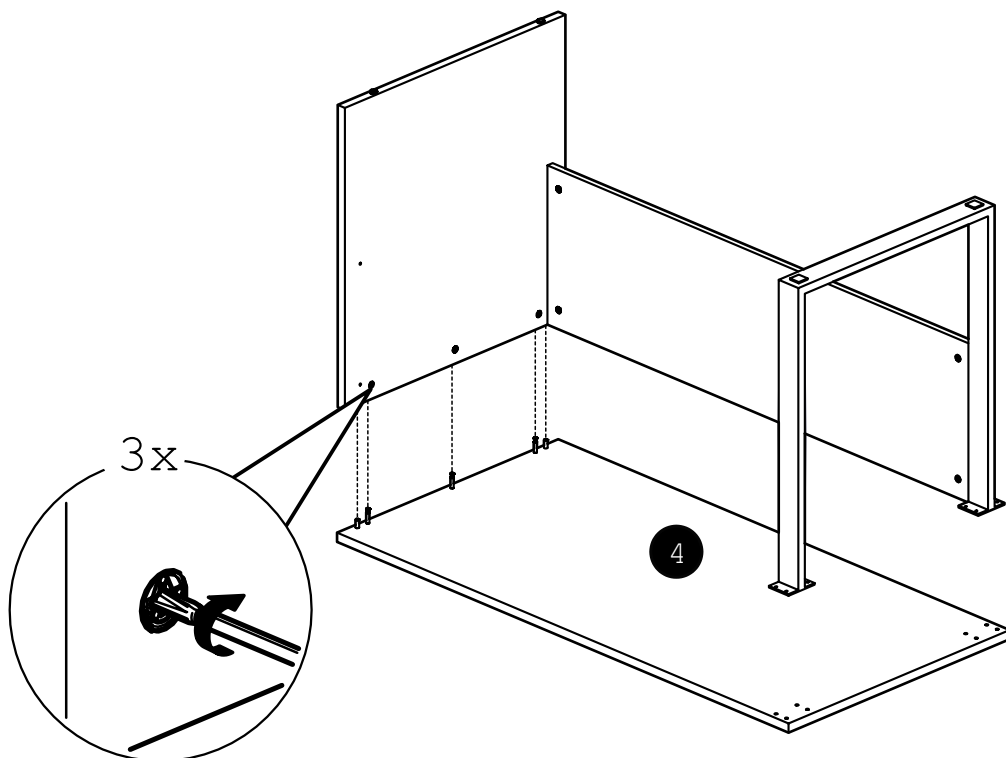

8

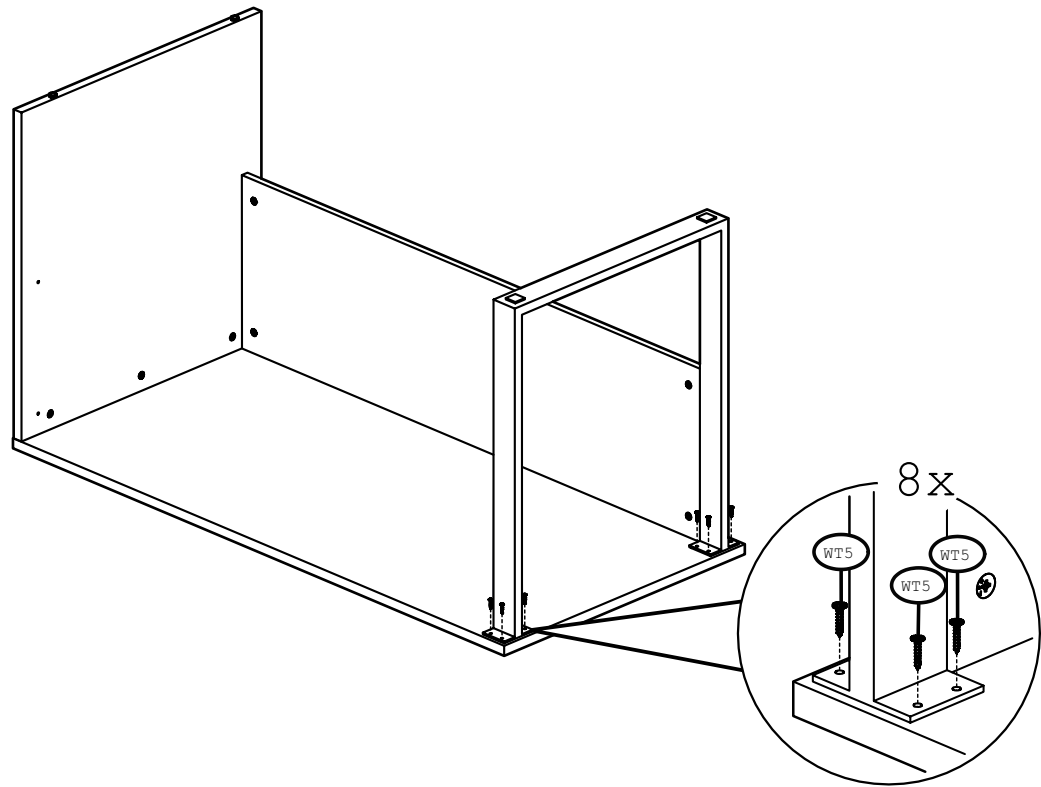
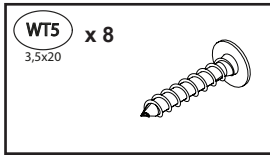

9

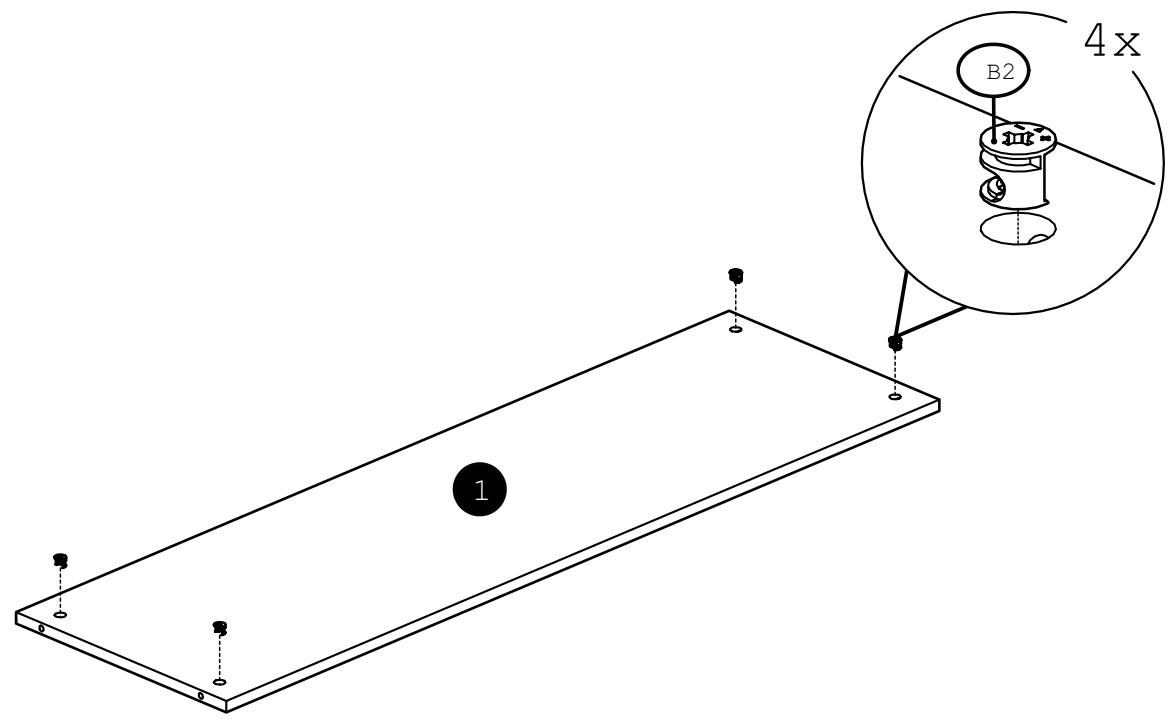
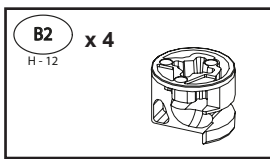

10

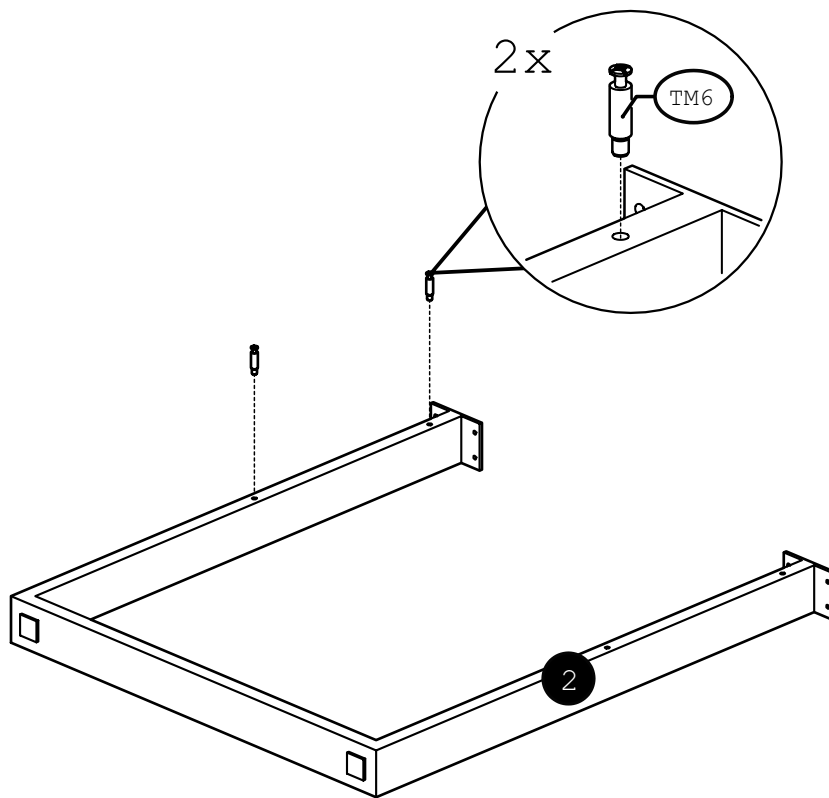
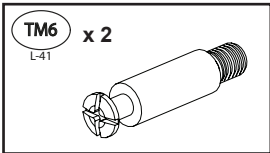

11

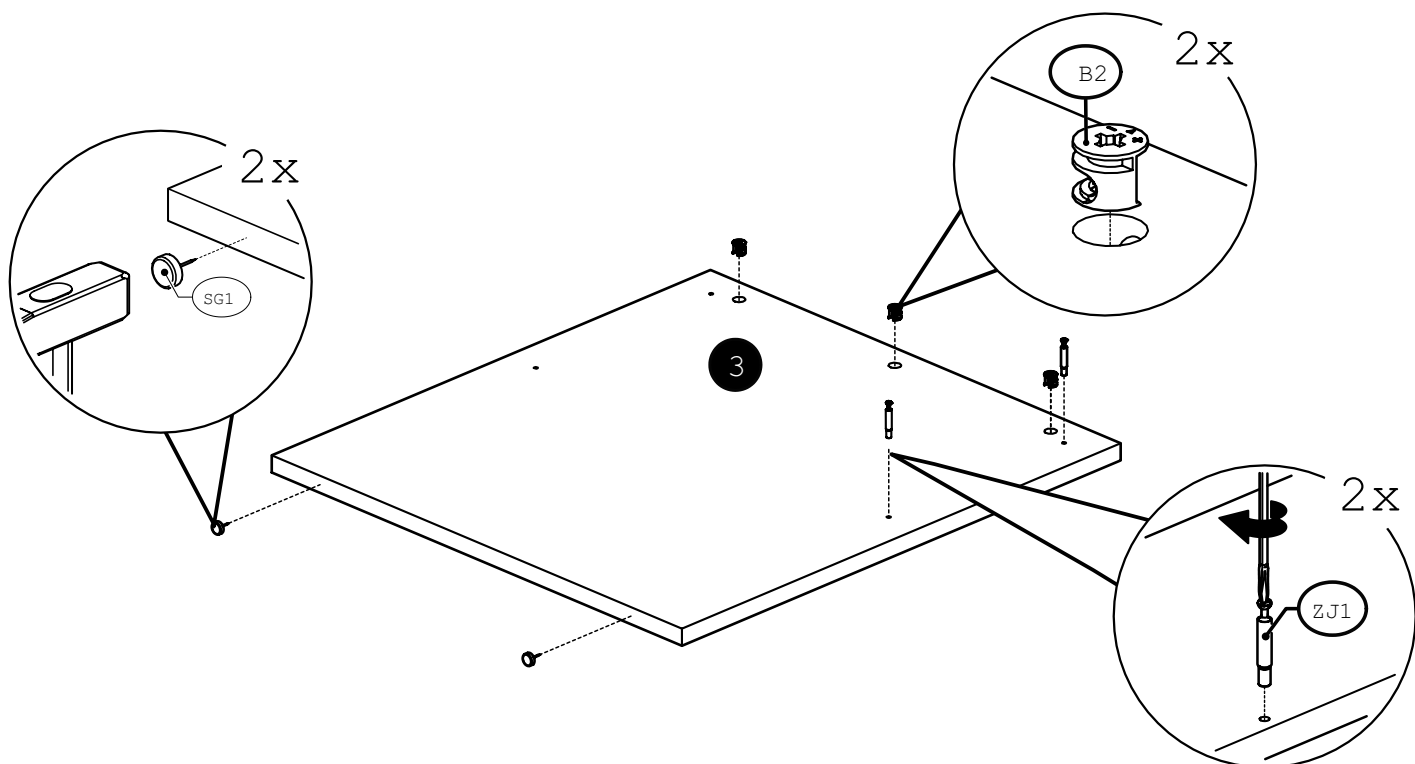
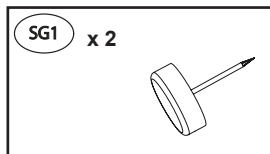
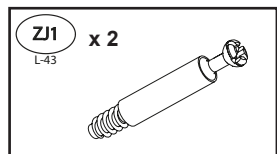
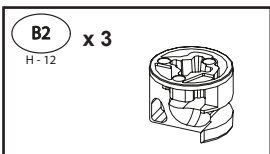

12

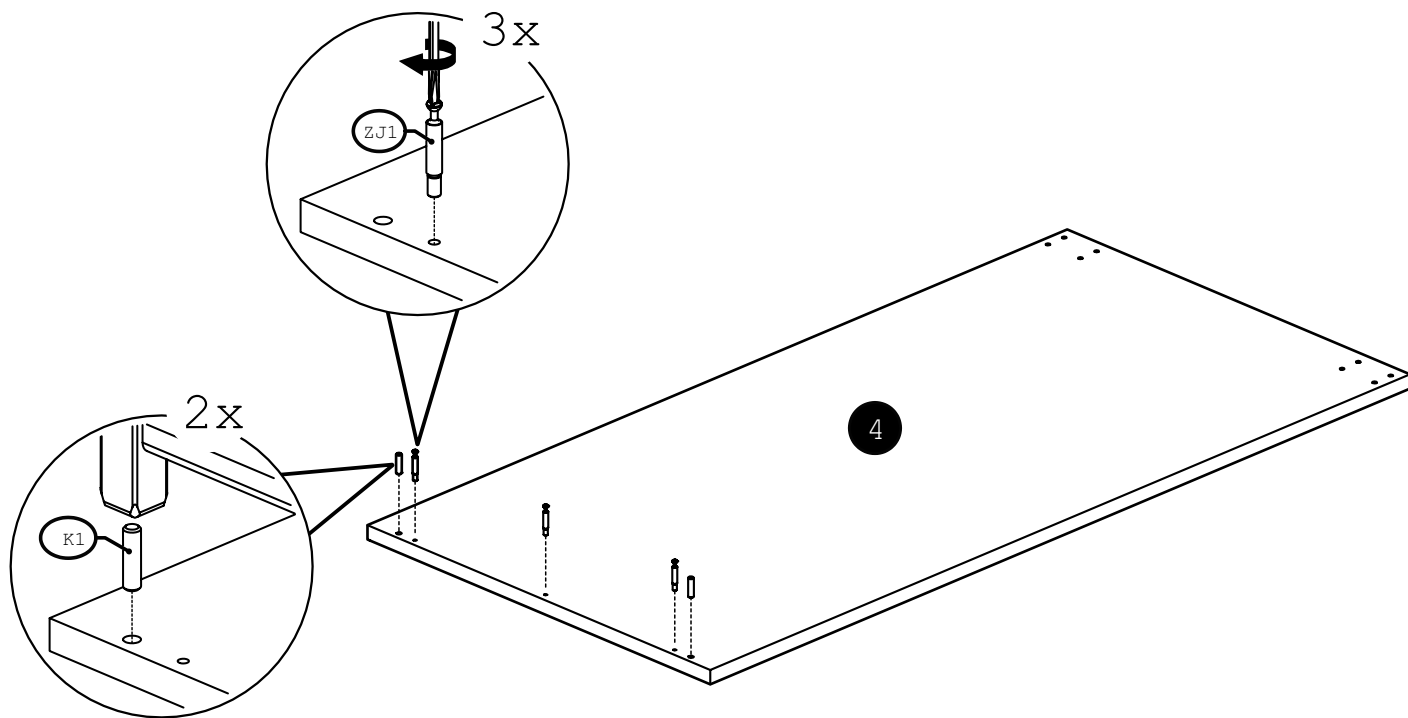
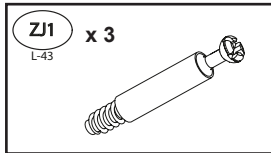
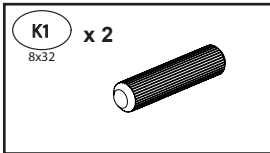

13

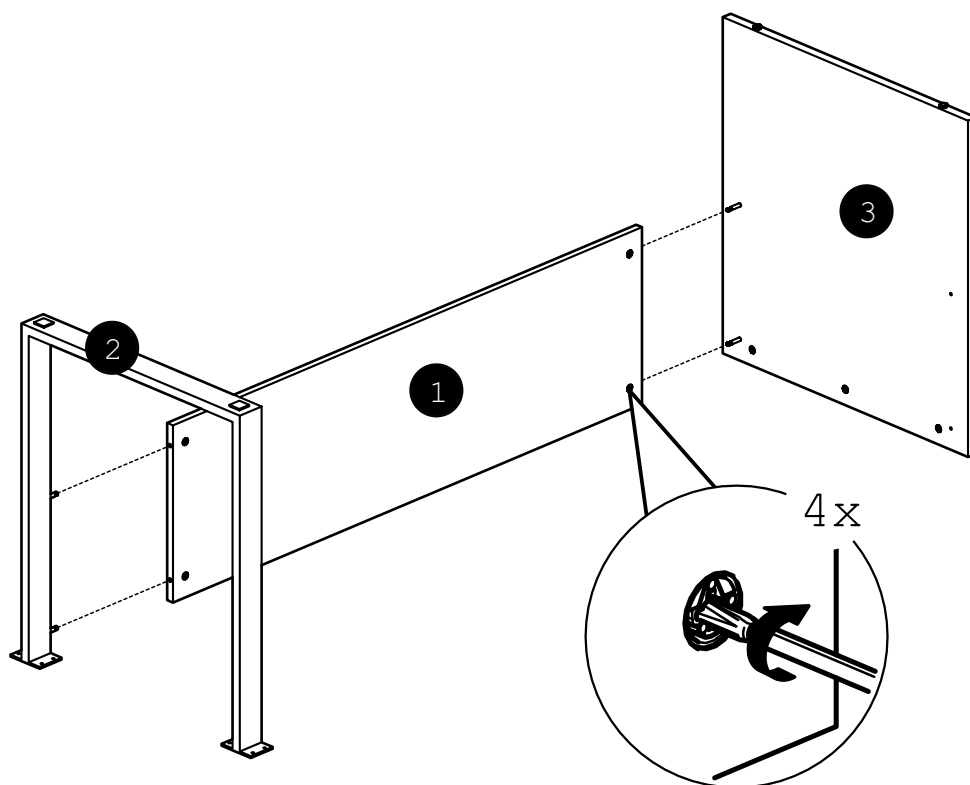

14

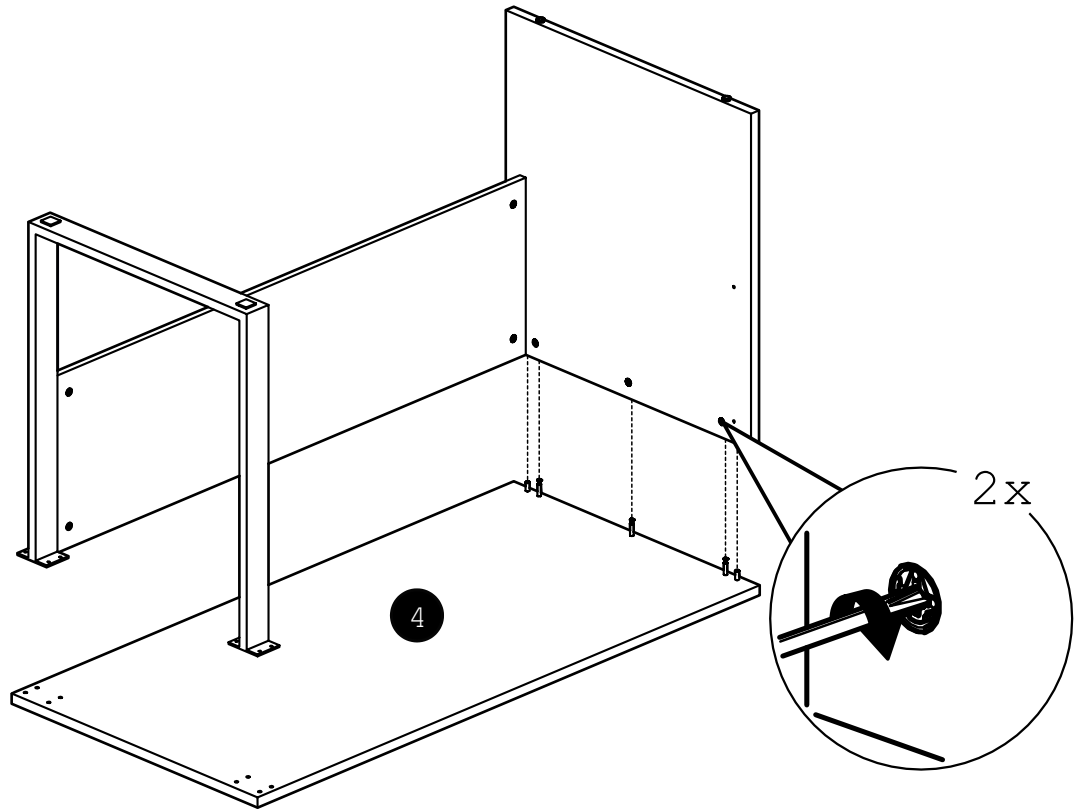

15

