



BARKY
QJ-233-CT(M)



A. (m6x16)x16



B. (m6x16)x16



C. (Φ4)x1

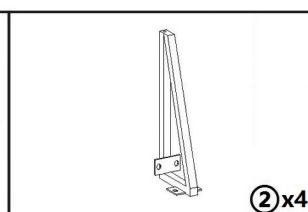
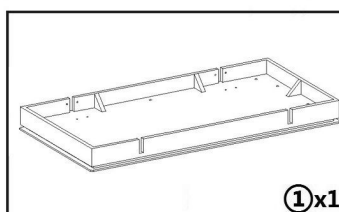
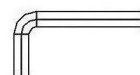

W CZASIE PROCESU MONTAŻU WSZYSTKIE ŚRUBY POWINNY BYĆ DOKRĘCANE NIE MOCNIEJ NIŻ 80%. DOPIERO PO ZAMONTOWANIU WSZYSTKICH ŚRUB PROSIMY DOKRĘCIĆ JE RÓWNOMIERNIE DO 100%. RÓWNIEŻ W TRAKCIE UŻYTKOWANIA STOLIKA ŚRUBY POWINNY BYĆ KILKA RAZY W ROKU DOKRĘCANE.

1

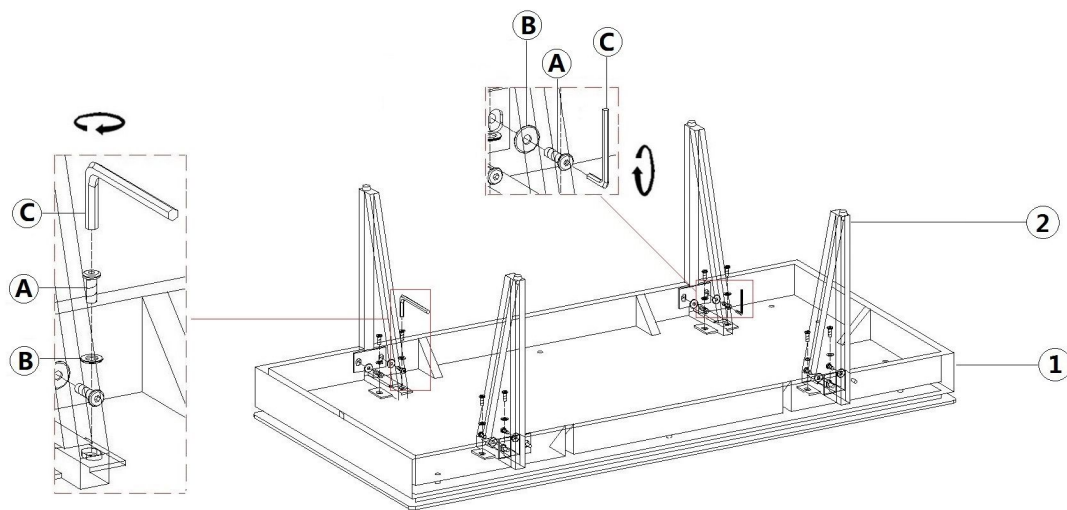

2

