

# CHANI

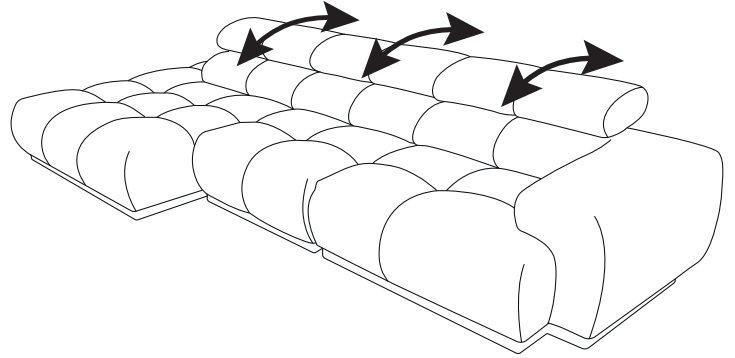

10min

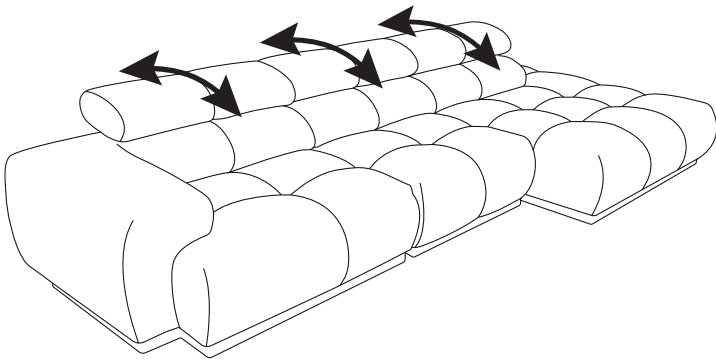
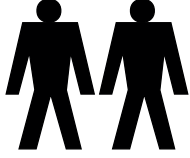

I

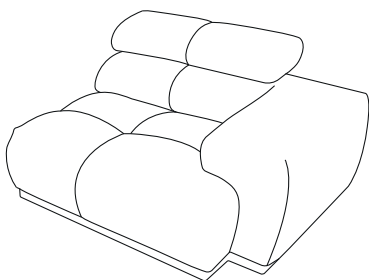
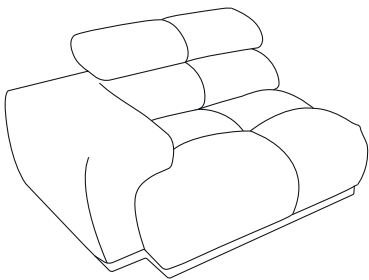

II

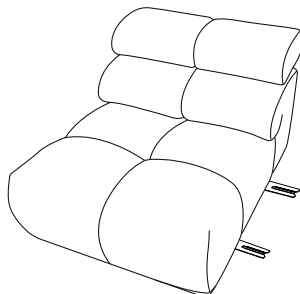
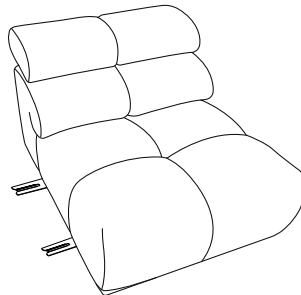

III

