

# WERONA

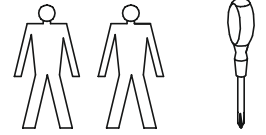

<p>A</p> <p>x1</p>	<p>B</p> <p>x1</p>	<p>C1</p> <p>x1</p>	<p>C2</p> <p>x1</p>	<p>D</p> <p>x1</p>	<p>E</p> <p>x1</p>	<p>F</p> <p>x1</p>	<p>G</p> <p>x3</p>
<p>H</p> <p>45mm</p> <p>x14</p>	<p>I</p> <p>M6 x 20</p> <p>x8</p>	<p>J</p> <p>x8</p>	<p>K</p> <p>x2</p>	<p>L</p> <p>x2</p>	<p>M</p> <p>x6</p>	<p>N</p> <p>x4</p>	<p>N</p> <p>x2</p>

I + II

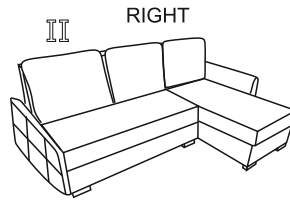
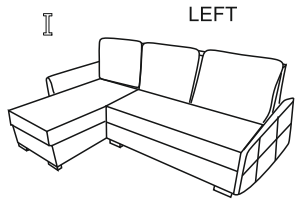
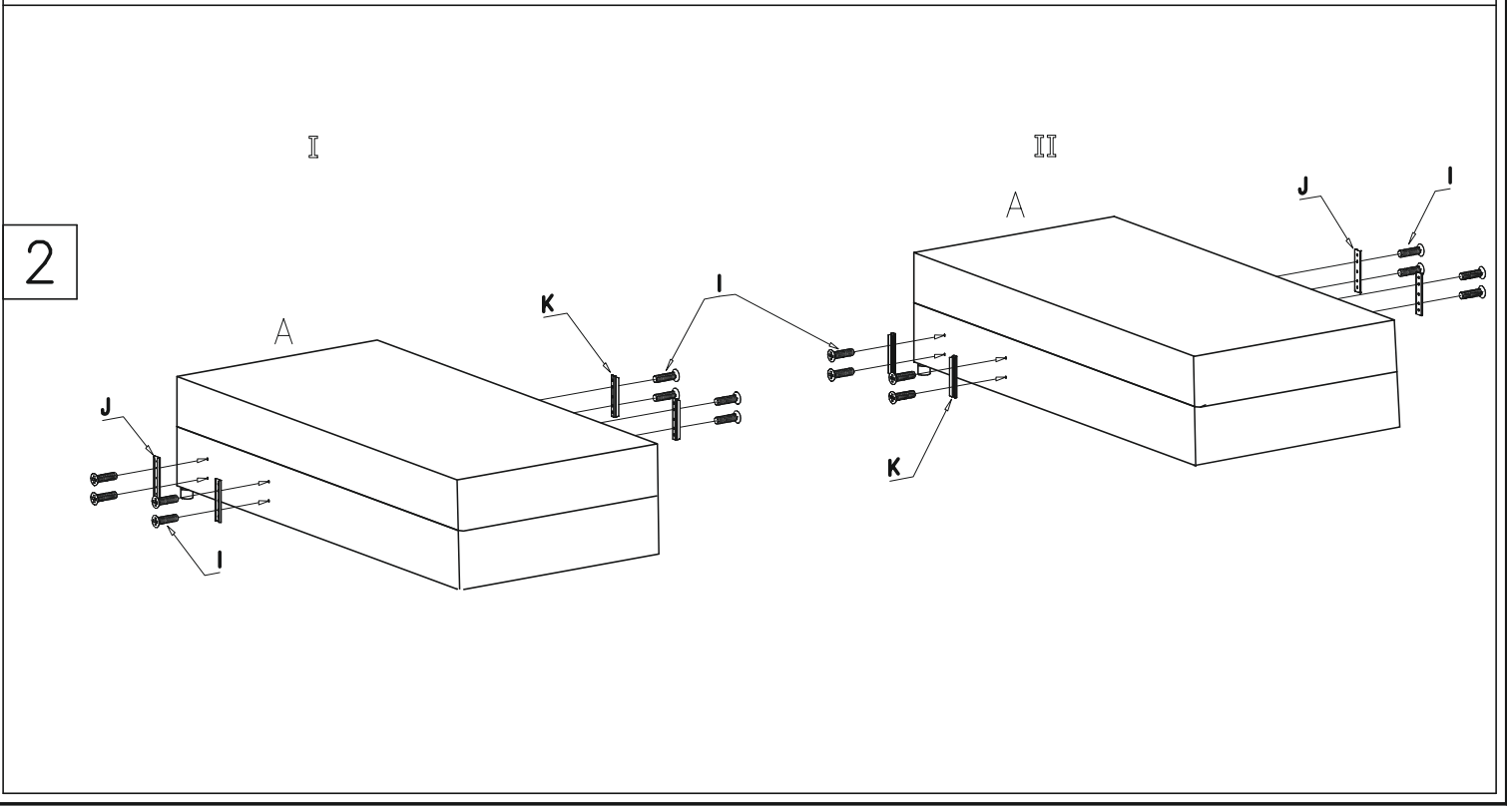
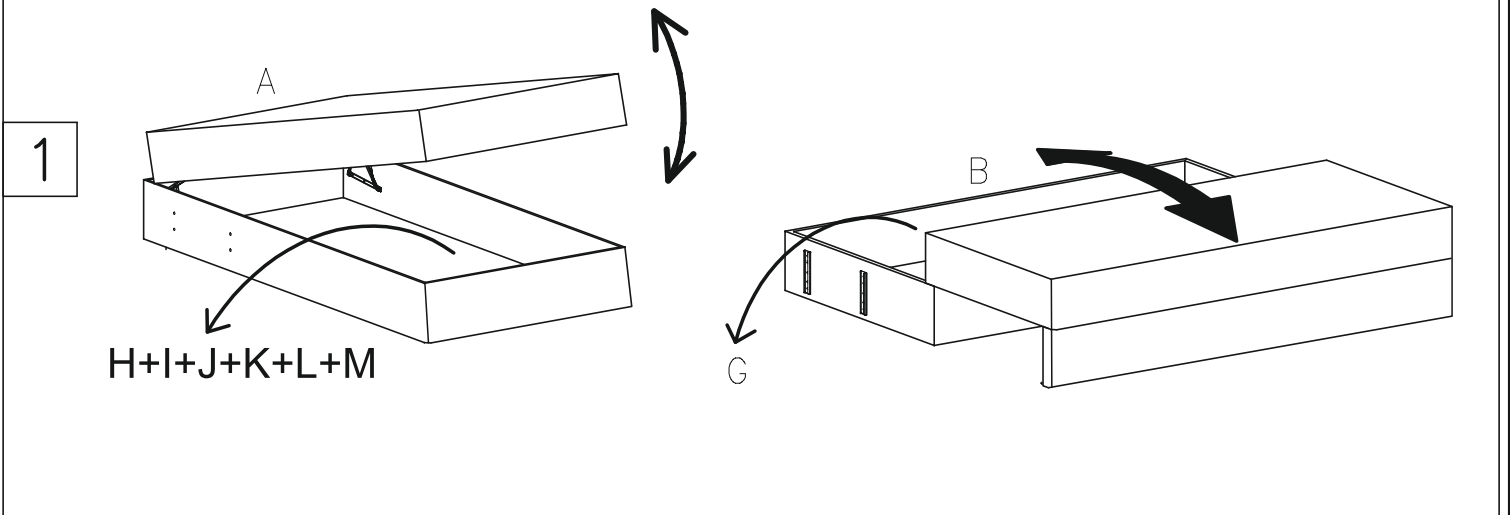

3

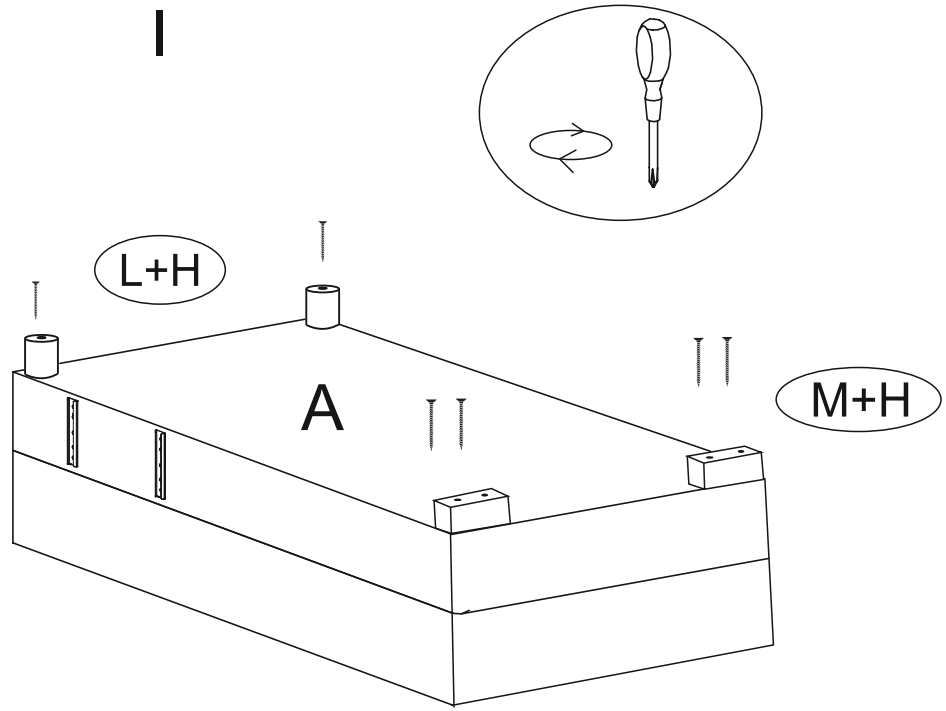

II

4

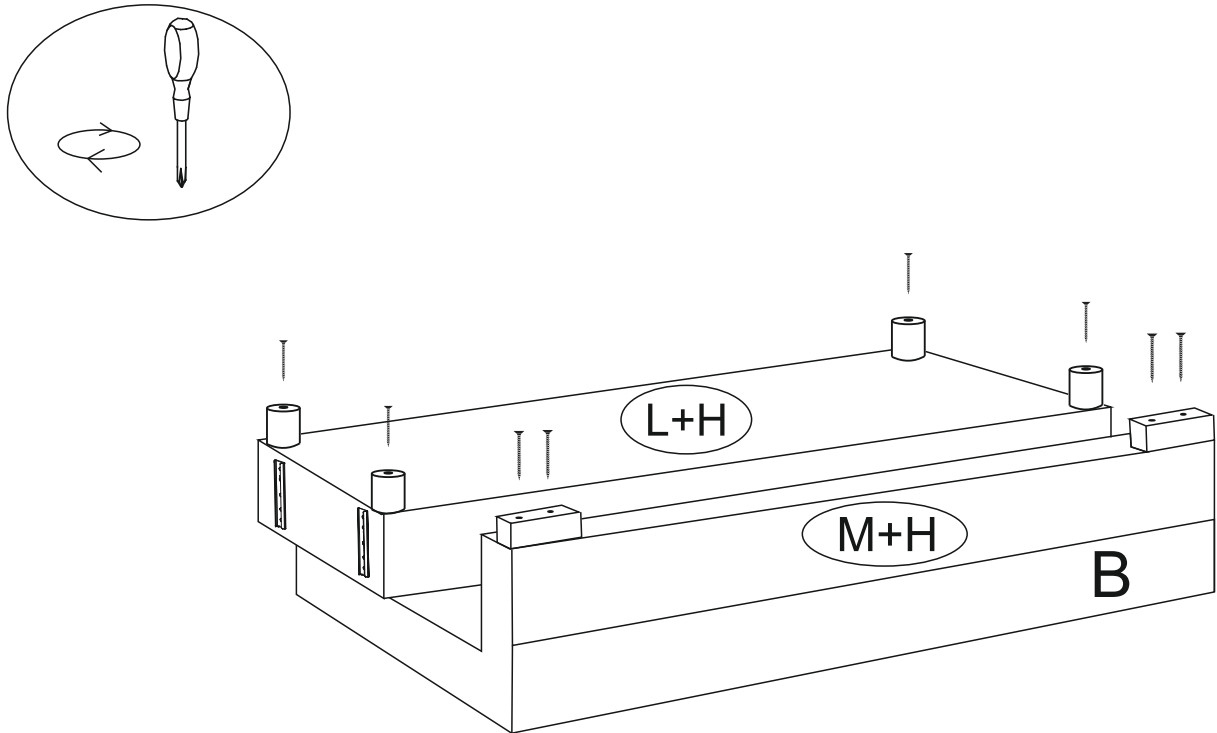

6

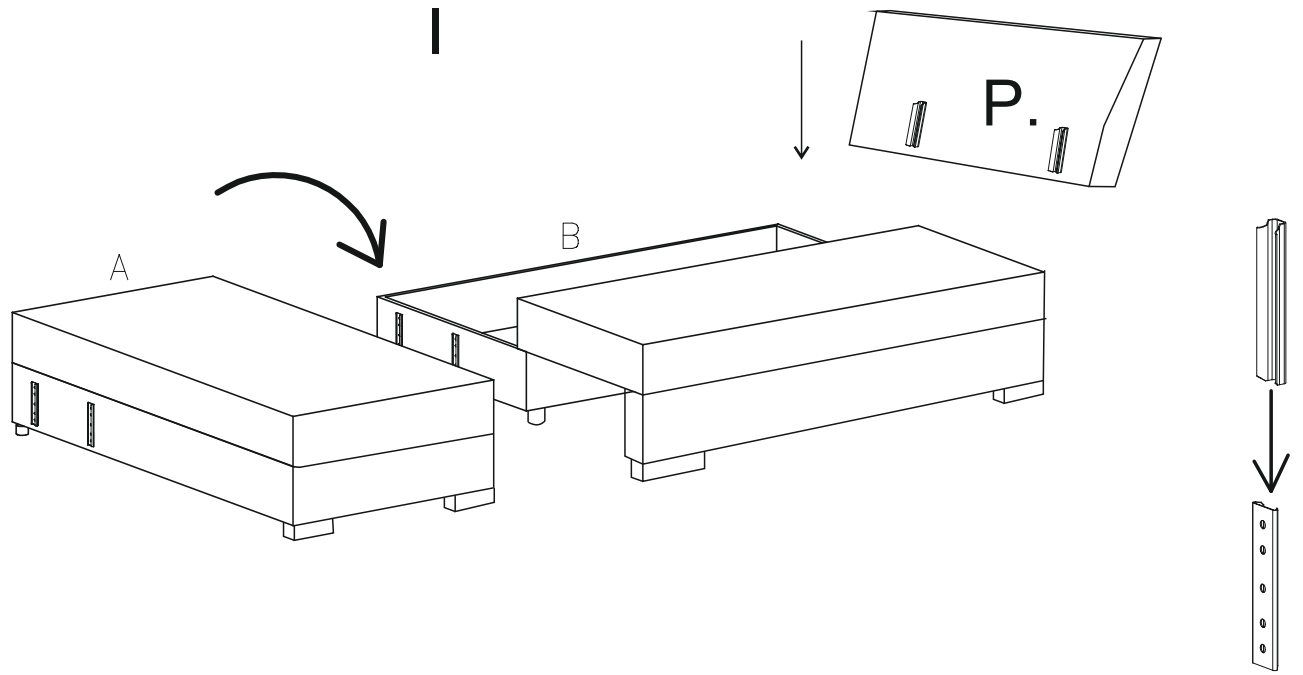

II

7

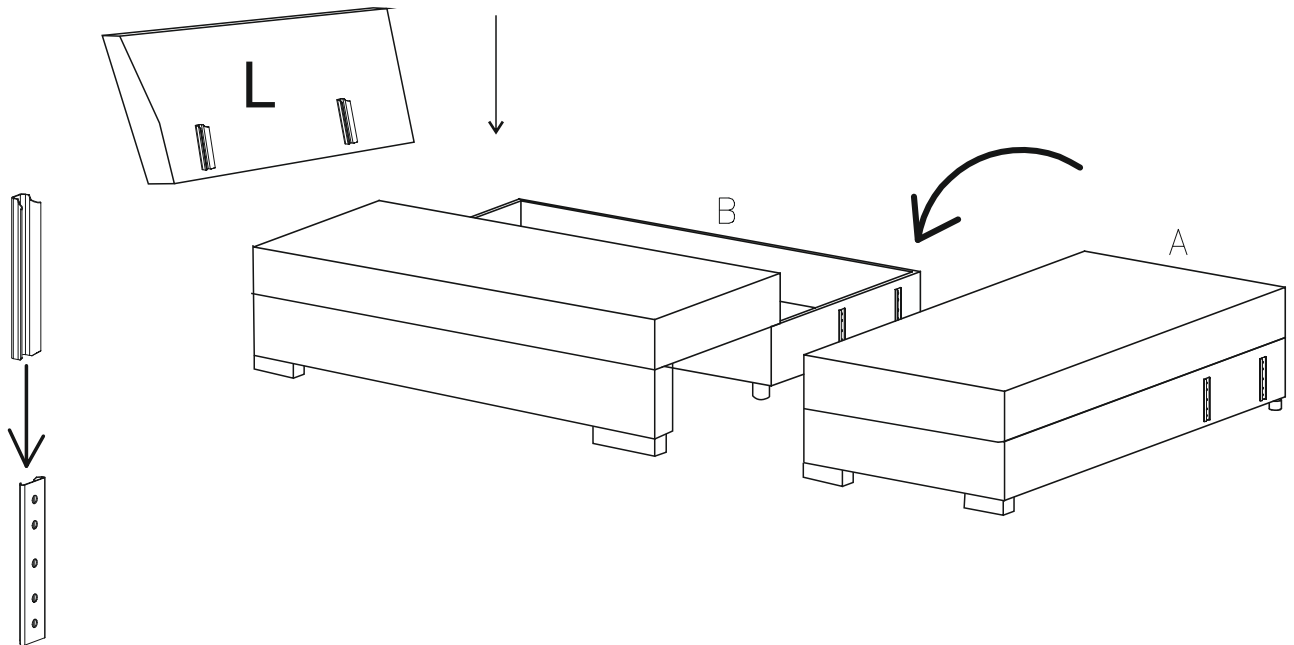

8

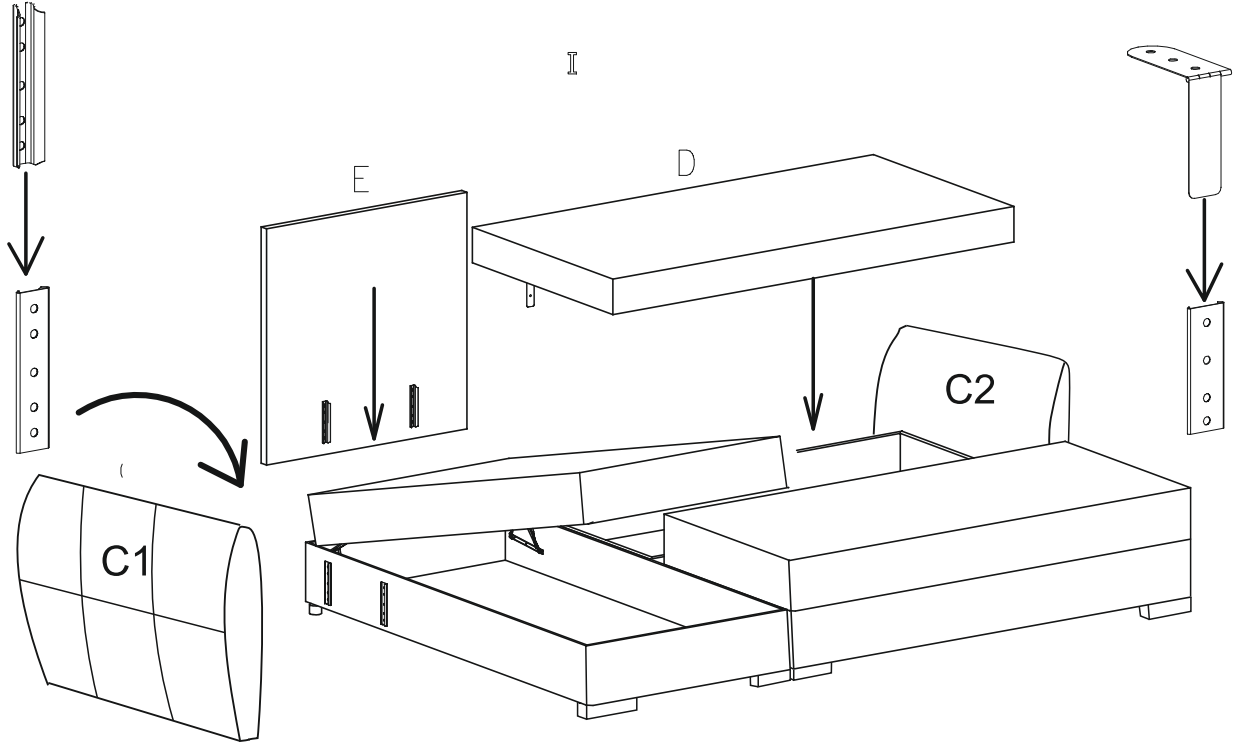

II

**Ostrzeżenie!**  
 Korzystanie z funkcji spania jest możliwe tylko po ustawieniu sofy wzdłuż ściany.  
 Po rozłożeniu funkcji spania należy dosunąć sofę do ściany, co uniemożliwia podniesienie się oparcia podczas korzystania z funkcji.  
 Podniesienie się oparcia może spowodować zsunięcie się z sofy, skutkiem czego może dojść do poważnych obrażeń.

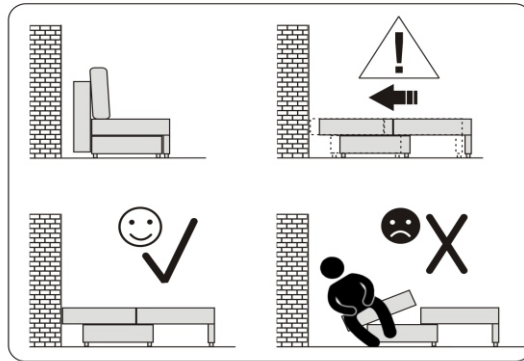

9

