

19

Ø3.0x20mm
P7
6

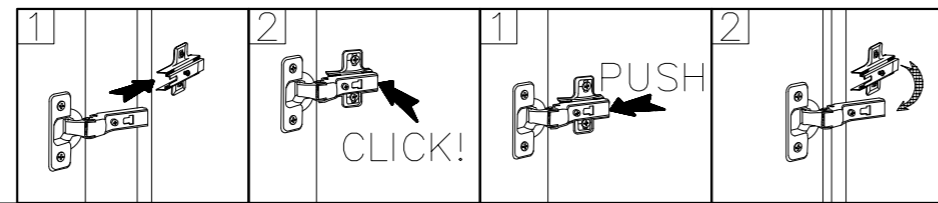
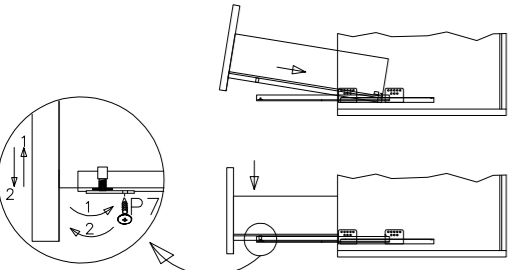
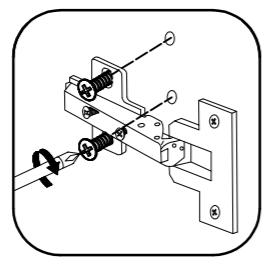
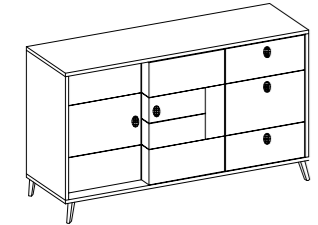
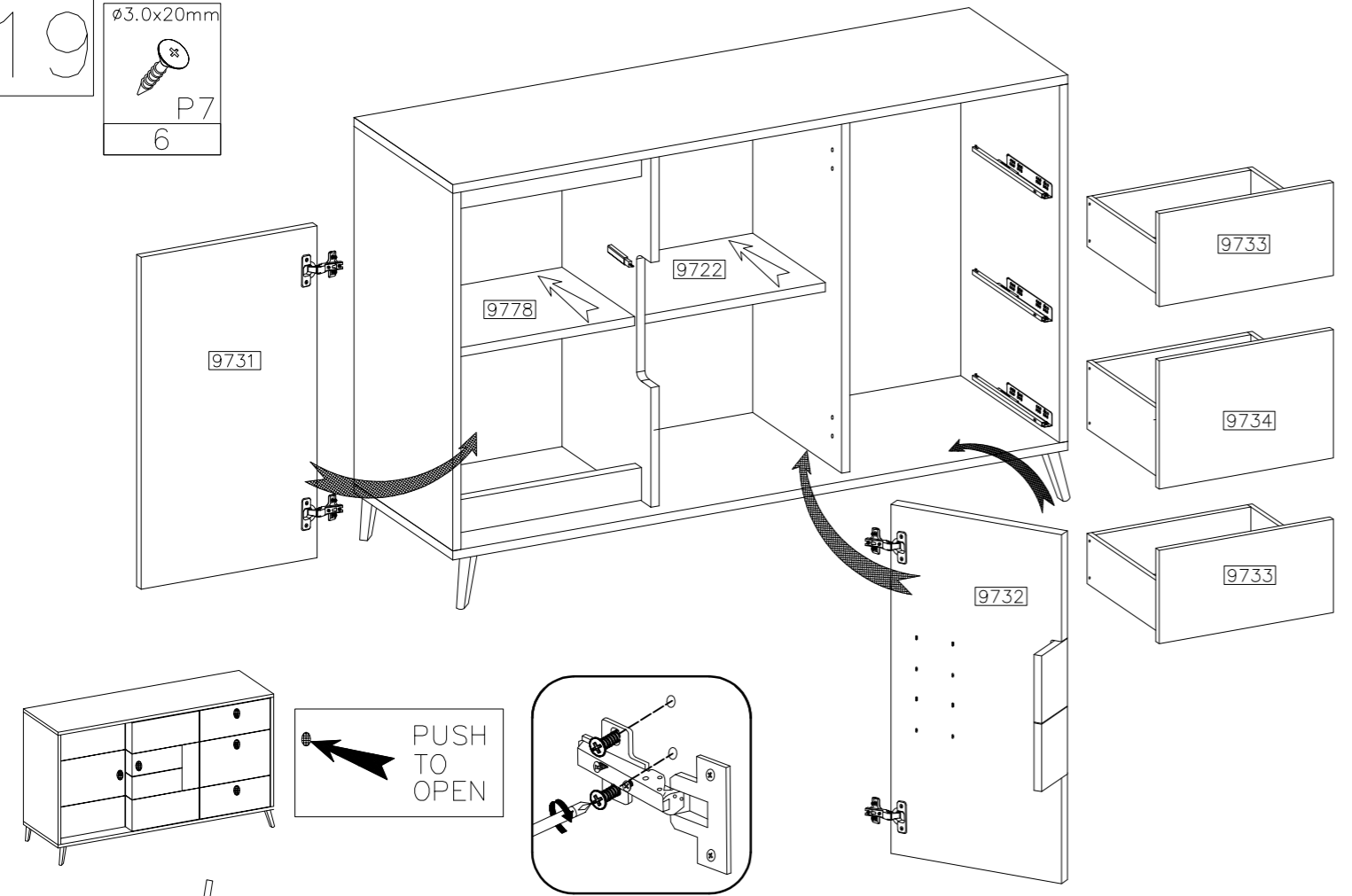

20

Ø3.5x16mm
N
1

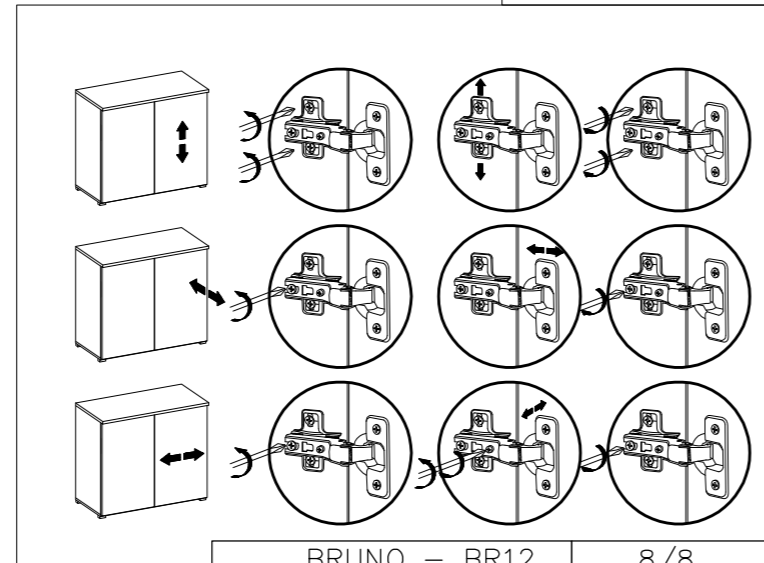
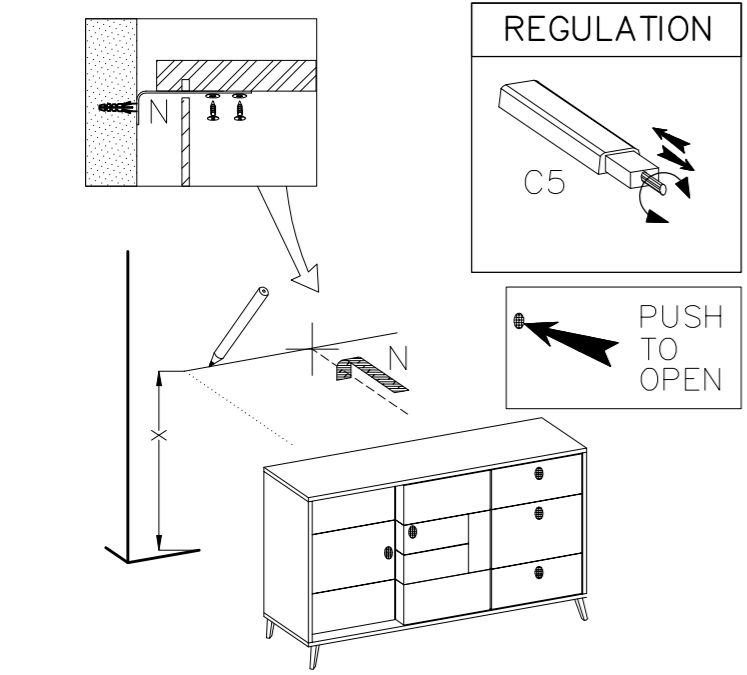
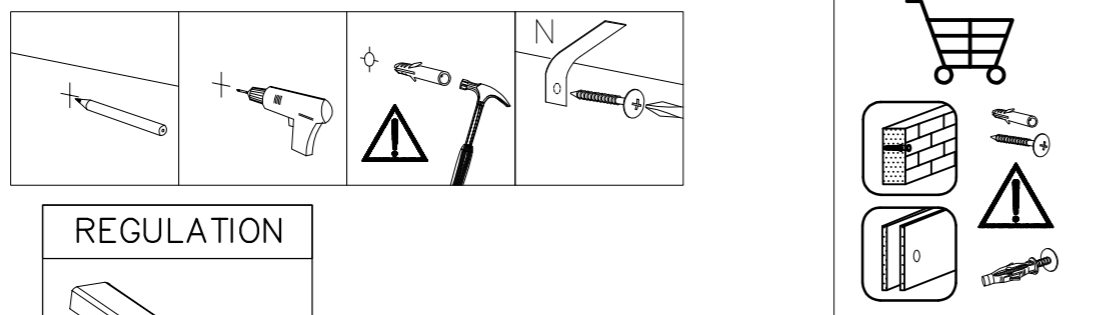

BRUNO BR12

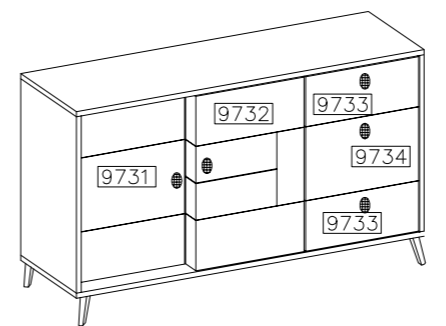
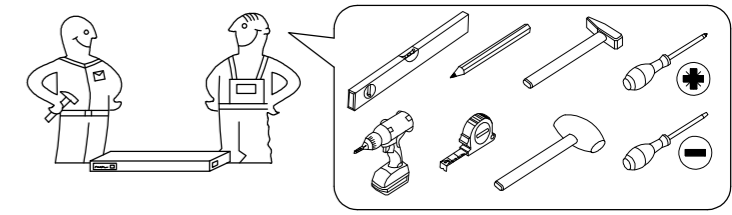

PUSH TO OPEN

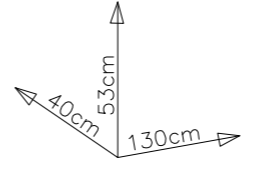

#	ART. NR	L	W	T	Q	Col.No
1	9715	768	404	16	1	1
2	9716	768	404	16	1	1
3	9717	768	364	16	1	1
4	9718	768	364	16	1	1
5	9778	413	314	16	1	1
6	9722	407	354	16	1	1
7	9705	373	223	16	1	1
8	9674	345	153	6	2	1
9	9675	56	153	6	2	1
10	9700	1300	404	16	1	2
11	9701	1300	404	16	1	2
12	9703	300	240	16	1	2
13	9704	300	240	16	1	2
14	9723	300	160	16	2	2
15	9724	300	160	16	2	2
16	9725	373	143	16	2	2
17	9729	407	60	16	2	2
18	9713	388	308	2,5	3	2
19	9739	429	783	2,5	2	2
20	9740	424	783	2,5	1	2
21	9731	728	407	16	1	3
22	9732	760	438	16	1	3
23	9733	220	407	16	2	3
24	9734	311	407	16	1	3
25	9673	310	100	10	1	3

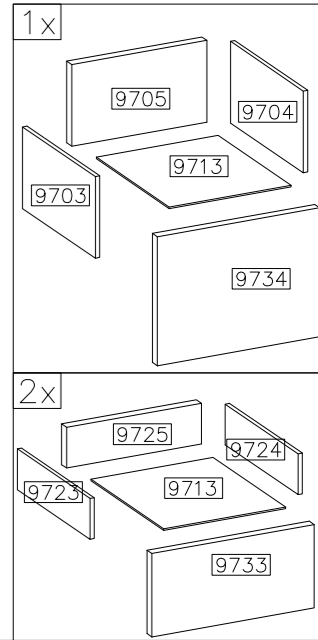
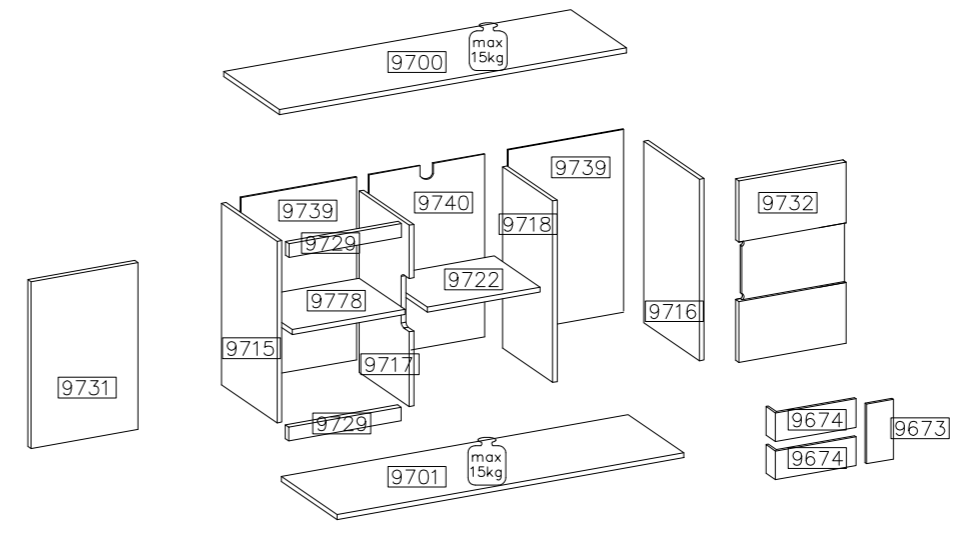

Ø8x30mm A 36	6,4x50mm B 8	Ø15/12mm C 16	D1 16	E 16	E1 8	Ø35/KR-15 G7 2	Ø35/KR-0 G6 2	3.0x13mm P13 12	J4 8
O 1	Ø5.0x13mm P9 20	L 12	C5 2	Ø3.5x16mm P4 4	Ø3.5x16mm N 1	U 12			
F8 14	Ø3.0x16mm P1 26	L 3SET	PR2 5	F4 15	Ø4.0x20mm P8 6	Ø3.0x20mm P7 6			

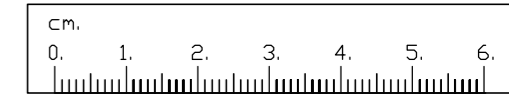

1

$\varnothing 8 \times 30 \text{mm}$
A
8

2x

2

D1
8

3

$\varnothing 15/12 \text{mm}$	$\varnothing 8 \times 30 \text{mm}$	$\varnothing 5.0 \times 13 \text{mm}$
C	A	P9
4	8	6
		J4
3SET		2

BRUNO - BR12 2/8

15

$\varnothing 8 \times 30 \text{mm}$
A
8
$\varnothing 15/12 \text{mm}$
C
4
D1
4

2x

16

U
8

2x

17

E
4

2x

BRUNO - BR12 7/8

18

$\varnothing 3.0 \times 16 \text{mm}$
P1
12

2x

BRUNO - BR12 7/8

11

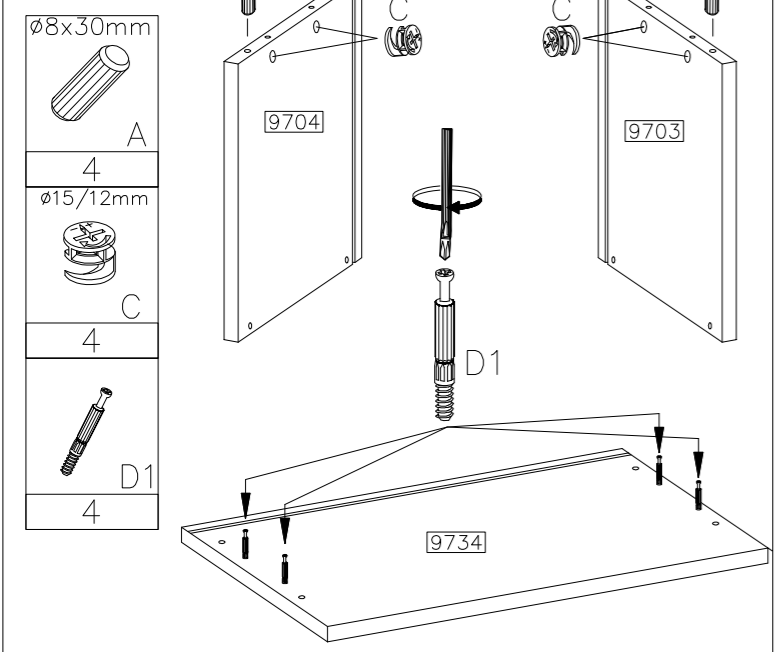

12

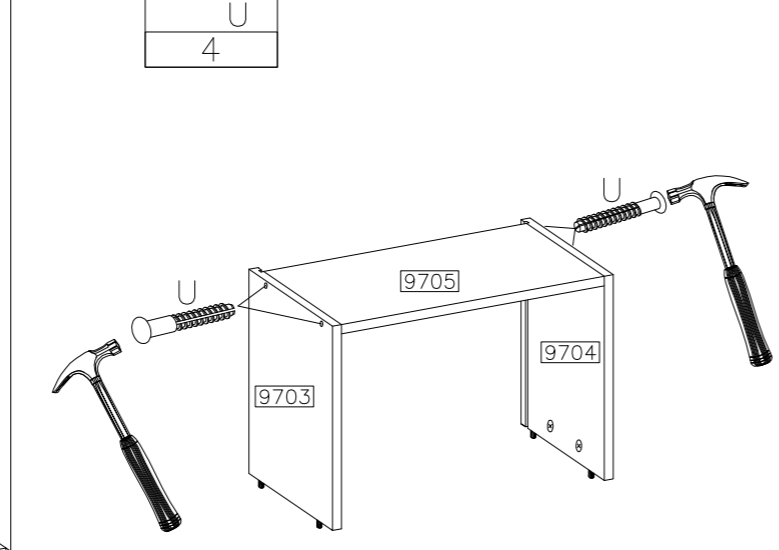

4

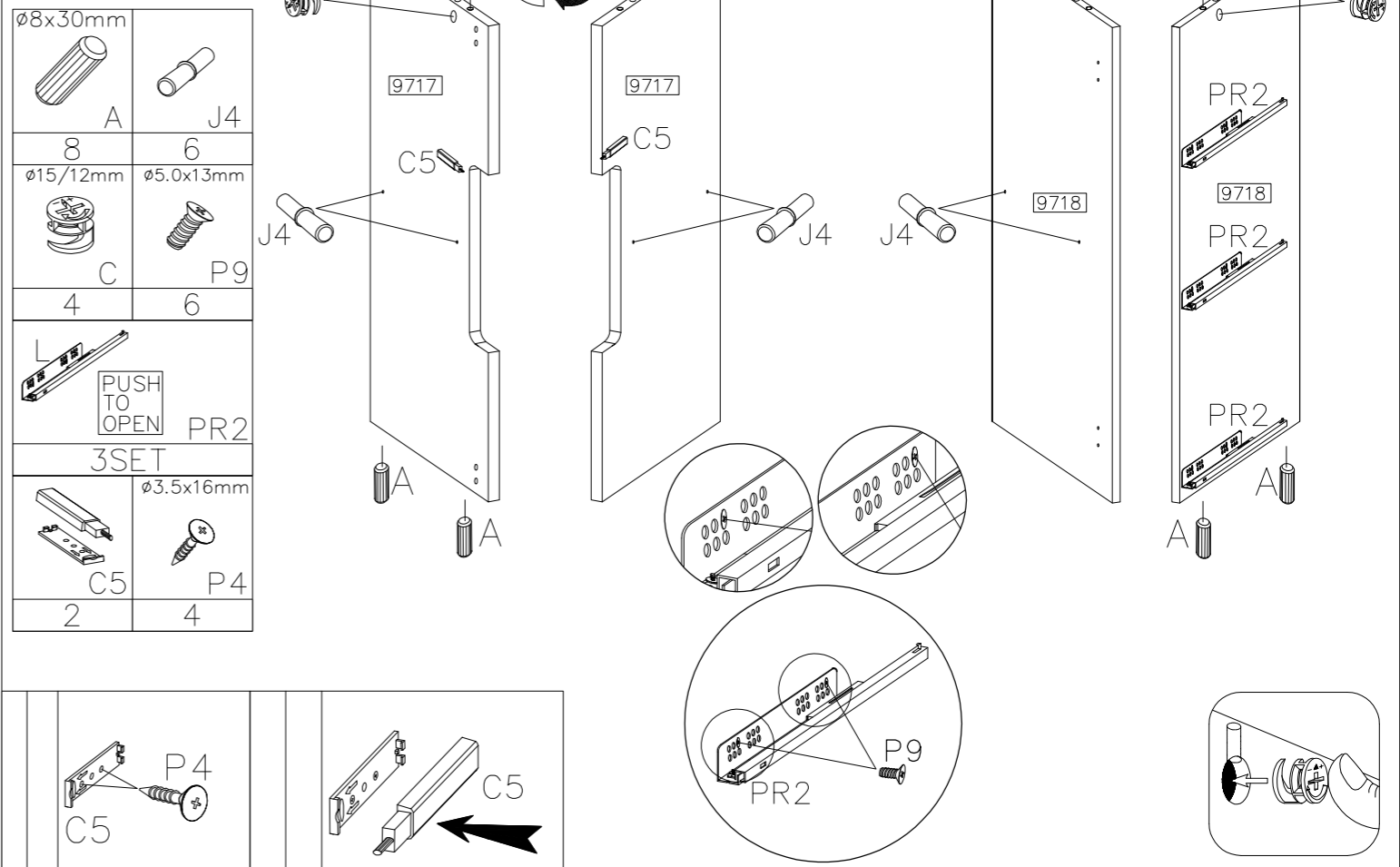

13

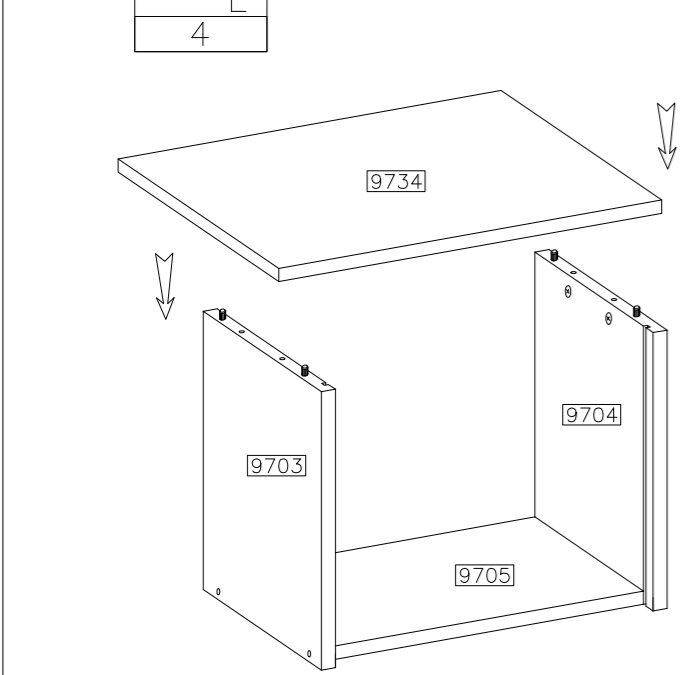

14

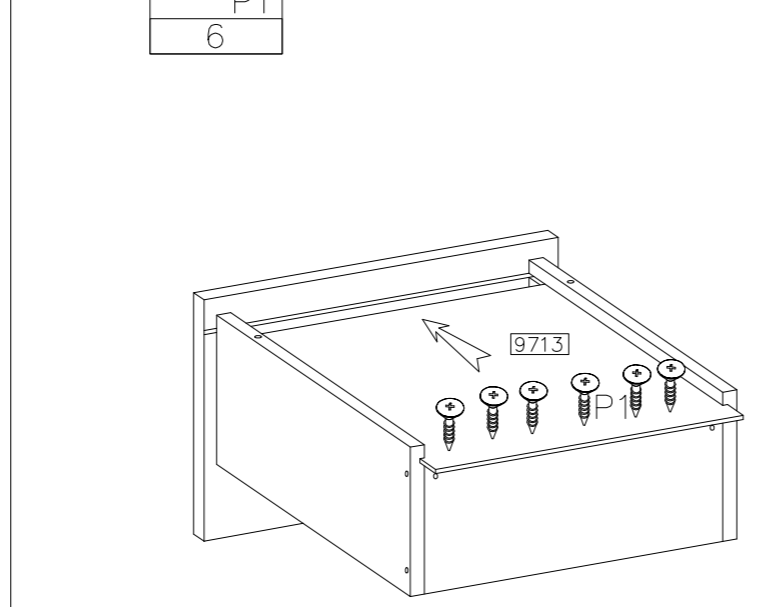

5

