







A.(m6x10)x4 	B.(m6x35)x4 	C.(m6x16)x8 
D.(Φ4)x1 		
		
①x1	②x1	③x2

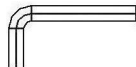

W CZASIE PROCESU MONTAŻU WSZYSTKIE ŚRUBY POWINNY BYĆ DOKRĘCANE NIE MOCNIEJ NIŻ 80%. DOPIERO PO ZAMONTOWANIU WSZYSTKICH ŚRUB PROSIMY DOKRĘCIĆ JE RÓWNOMIERNIE DO 100%. RÓWNIEŻ W TRAKCIE UŻYTKOWANIA STOLIKA ŚRUBY POWINNY BYĆ KILKA RAZY W ROKU DOKRĘCANE.

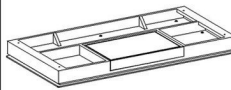
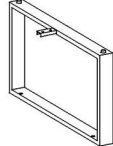
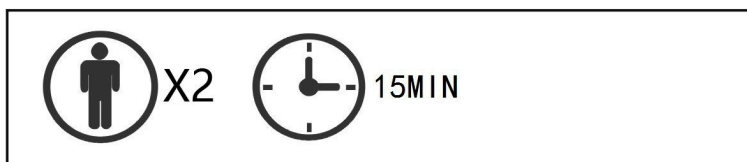