

# Instrukcja montażu mebli

## «DIESEL»

Komoda 4S

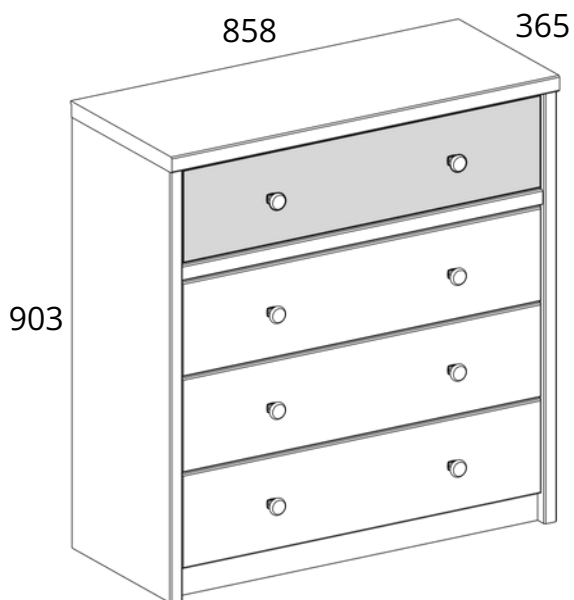







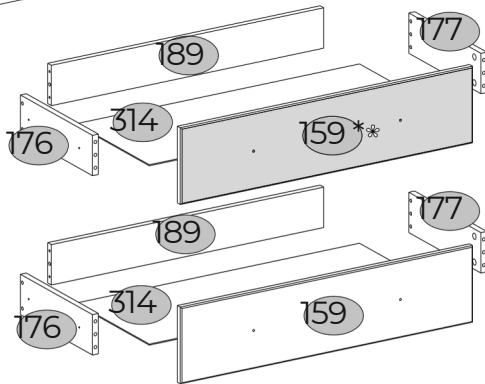
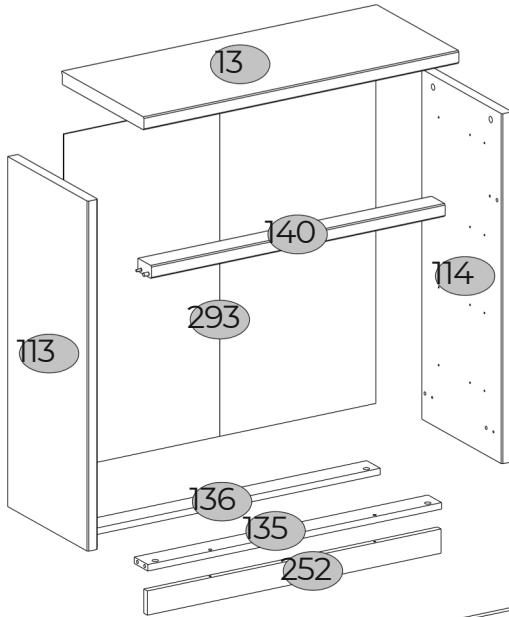
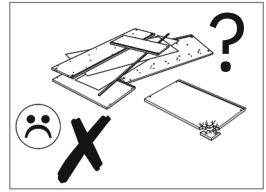

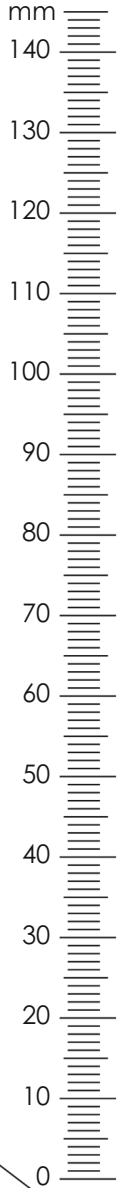





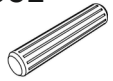



\_\_\_\_\_  
Production date  
Data produkcji

\_\_\_\_\_  
Stamp of Quality Department  
Pieczęć Działu Jakości

№	L, mm	B, mm	H, mm	Q	№ pack
13	858	365	32	1	1/2
113	867	355	28	1	1/2
114	867	355	28	1	1/2
135	800	60	16	1	1/2
136	800	60	16	1	1/2
140	800	60	32	1	1/2
159	796	190	16	3	2/2
159*	796	190	16	1	1/1
176	320	100	16	4	1/2
177	320	100	16	4	1/2
189	742	100	16	4	1/2
252	800	60	16	1	1/2
293	830	850	2,5	1	2/2
314	772	325	2,5	4	2/2





A1.0  5x28    26	A2  Ø15x13    26	B5  10x50    1
CC1  8x35    4206	G  6x26    22	H23  8
I  S4    1	L1  320    4	M4  M4x22    8
N1  4	R3  3x20    40	R24  7x50    18
R27  5,0x13    40	R102  3,5x16    8	S5  Ø18    16
S6  1	Z10  300    4	

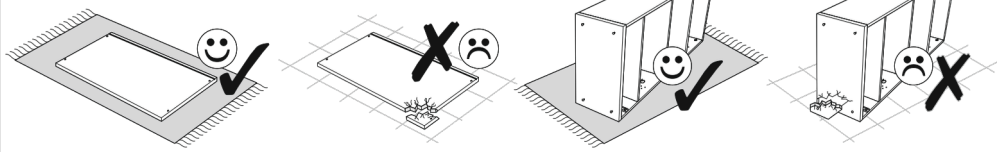
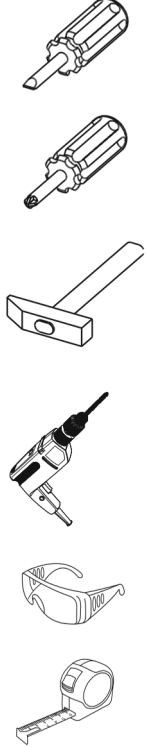

1

A1.0  
5x28



A2  
6 Ø15x13



CC1  
4 8x35



R27  
40 4,0x13

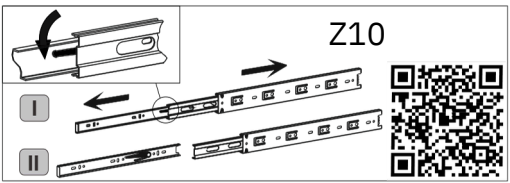

Z10  
24 300 4

Z10

139 6477

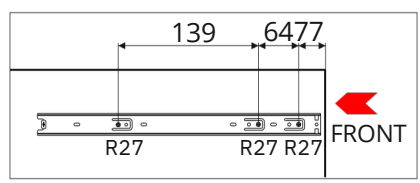
R27 R27 R27

FRONT

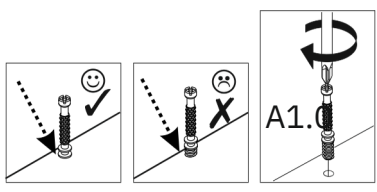

A1.0

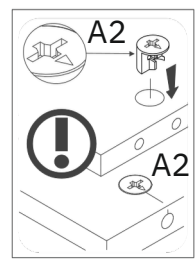

A2

A2

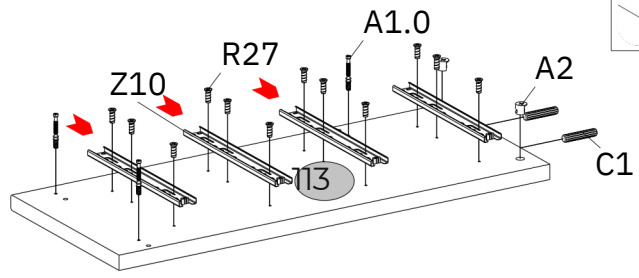

Z10 R27 A1.0 A2 C1

13

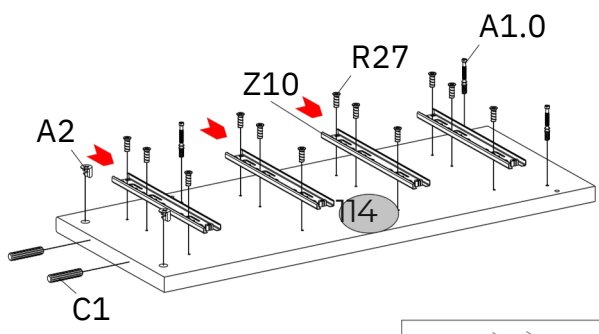

A2 Z10 R27 A1.0 C1

14

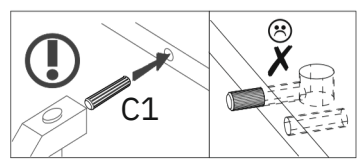

C1

2

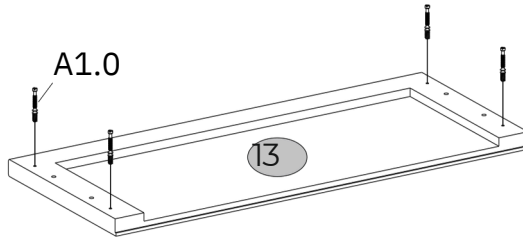
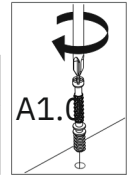
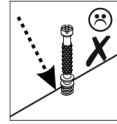
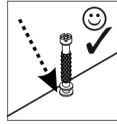
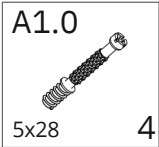

3

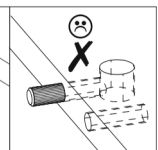
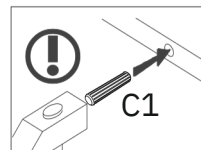
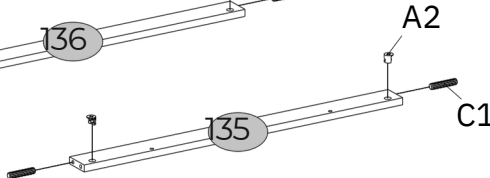
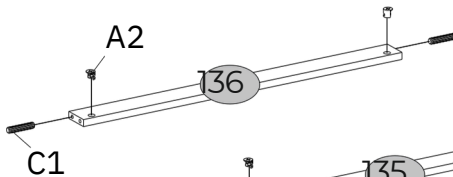
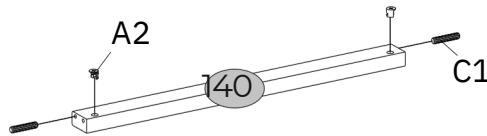
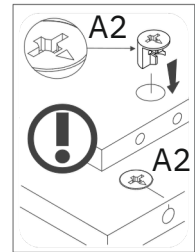
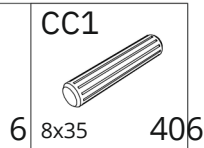
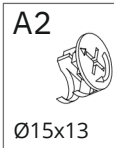

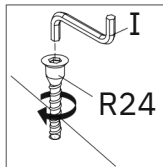
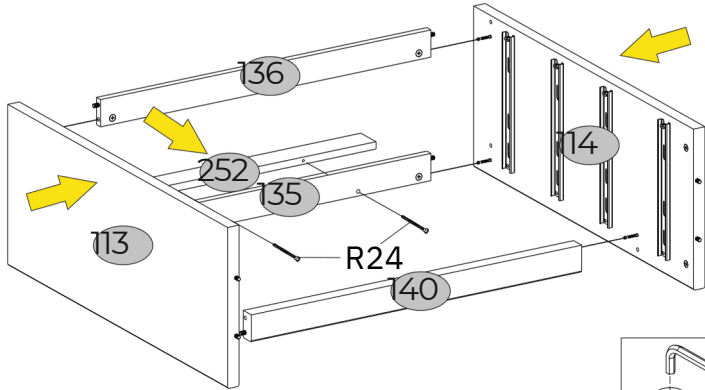
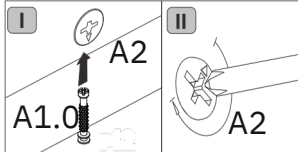
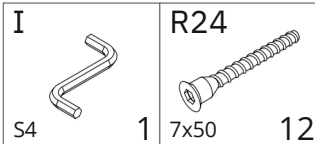

4

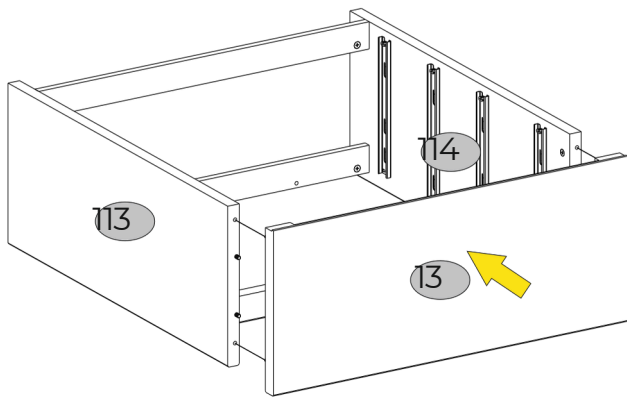
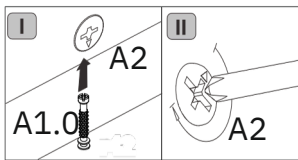

5



6

<b>G</b>  1,5x26 22	<b>N1</b>  4
--	---

I

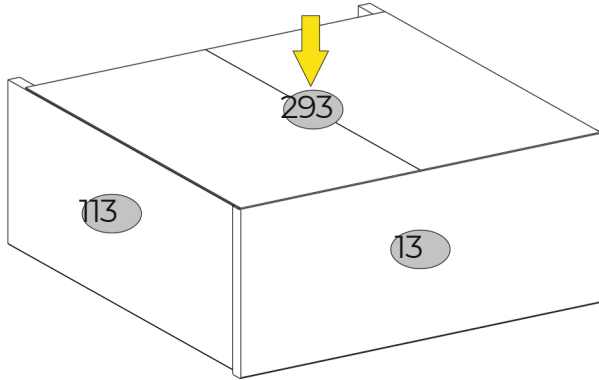

II

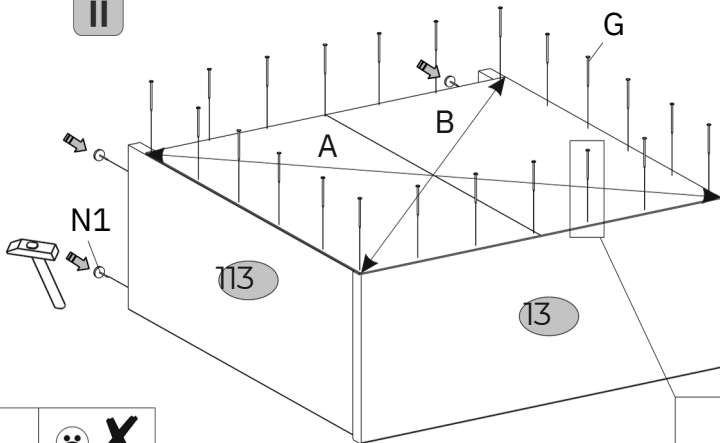

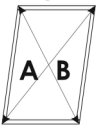
$A=B$ 90	 
-------------	--

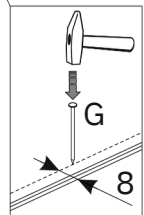
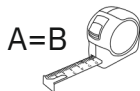



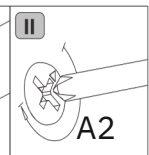
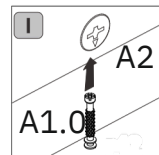
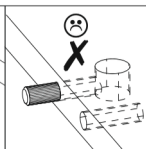
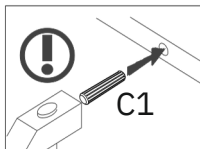
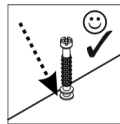
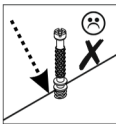
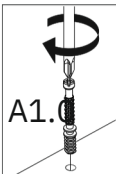
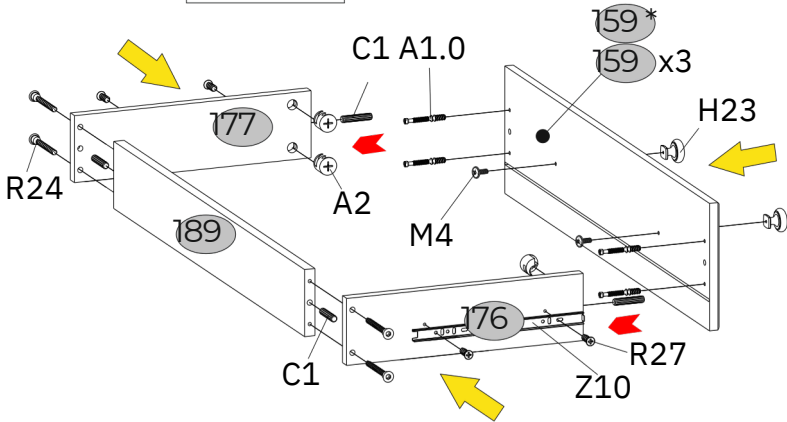
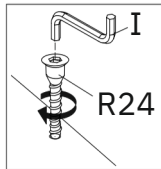
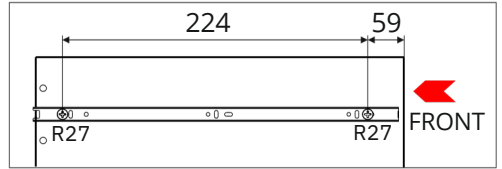
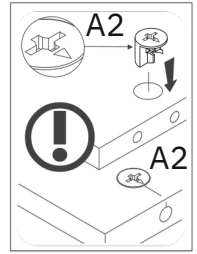

**7**  
x4

A1.0 5x28 16	A2 Ø15x13 16	CC1 8x35 16	H23 4106 8
I S4 1	M4 M4x22 8	R24 7x50 16	R27 5,0x13 16
Z10 300 4			





**8**  
x4

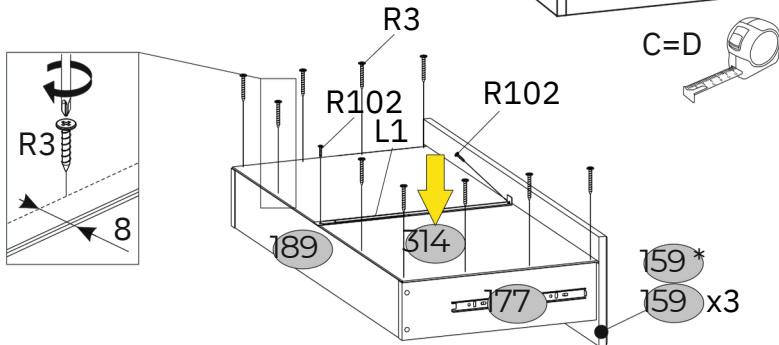
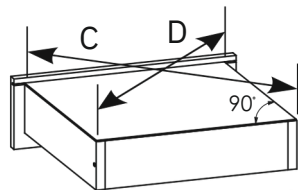

L1  320	R3  4 3x20	R102  40 3,5x16	8
--	---	--	---

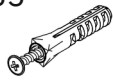

**9**

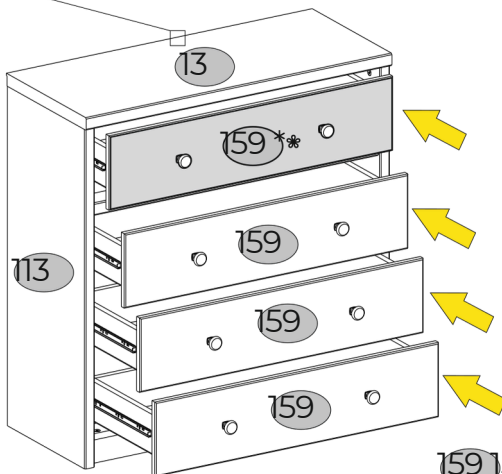
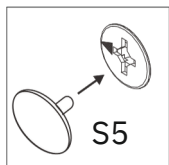
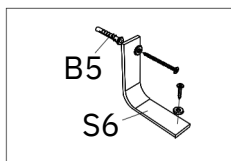
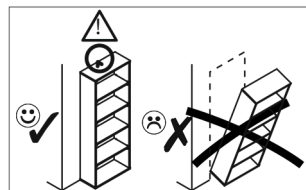
B5  10x50	S5  1 Ø18	S6  16	1
--	--	---	---



 max. 5 kg  
 max. 15 kg